



**SAFETY RELIEF
VALVES**



PRESSURE RELIEF VALVE SELECTION CHART

Model	Material Body / Trim	Inlet Sizes Min / Max, in.	Inlet Sizes Min / Max, mm.	Connections		CE/PED Available	Set Pressures Min / Max, PSIG	Set Pressures Min / Max, barg	Temperature Max, °F	Temperature Max, °C
				NPT	Flanged					
ASME Section I - Steam Power Boilers										
19M	Bronze / Brass	1/2 - 2 1/2	DN 15 - 65	X		X	15 - 250	1.0 - 17.2	406°F	207.7°C
19K	Bronze / Brass	1/2 - 2 1/2	DN 15 - 65	X		X	15 - 250	1.0 - 17.2	406°F	207.7°C
19L	Bronze / Stainless	1/2 - 2 1/2	DN 15 - 65	X		X	15 - 250	1.0 - 17.2	406°F	207.7°C
19S	Bronze / Stainless	1/2 - 2 1/2	DN 15 - 65	X		X	15 - 300	1.0 - 20.7	422°F	216.7°C
29	Bronze / Brass	3/8 - 1 1/4	DN 10 - 32	X		X	30 - 200	2.0 - 13.8	406°F	207.7°C
119	Cast Iron / Stainless	1-1/2 - 6	DN 40 - 150	X	X	X	15 - 250	1.0 - 17.2	450°F	232.2°C
ASME Section IV - Low Pressure Steam Heating Boilers										
12	Bronze / Brass	2 - 3	DN 50 - 80	X			5 - 15	0.34 - 1.0	250°F	121.1°C
13-101	Bronze / Brass	3/4	DN 20	X			5 - 15	0.34 - 1.0	250°F	121.1°C
13-202	Bronze / Brass	1	DN 25	X			5 - 15	0.34 - 1.0	250°F	121.1°C
13-211	Bronze / Brass	3/4	DN 20	X			5 - 15	0.34 - 1.0	250°F	121.1°C
13-213	Bronze / Brass	1-1/4	DN 32	X			5 - 15	0.34 - 1.0	250°F	121.1°C
13-214	Bronze / Brass	1-1/2	DN 40	X			5 - 15	0.34 - 1.0	250°F	121.1°C
13-510	Bronze / Brass	3/4	DN 20	X			5 - 15	0.34 - 1.0	250°F	121.1°C
14-200	Bronze / Brass	2 - 3	DN 50 - 80	X			5 - 15	0.34 - 1.0	250°F	121.1°C
ASME Section IV - Hot Water Heating & Supply Boilers										
10-100	Bronze / Brass	3/4	DN 20	X			20 - 65	1.4 - 4.5	250°F	121.1°C
10-300	Bronze / Brass	3/4	DN 20	X			20 - 65	1.4 - 4.5	250°F	121.1°C
10-400	Bronze / Brass	3/4	DN 20	X			30	2.0	250°F	121.1°C
10-410	Bronze / Brass	3/4	DN 20	X			20 - 80	1.4 - 5.5	250°F	121.1°C
10-600, 10-610	Bronze / Brass	3/4 - 2	DN 20 - 50	X		X	15 - 160	1.0 - 11.0	250°F	121.1°C
10-624, 10-634	Bronze / Brass	3/4	DN 20	X			30 - 150	2.0 - 10.3	250°F	121.1°C
17-401	Bronze / Brass	1/2	DN 15	X			75 - 160	5.2 - 11.0	250°F	121.1°C
17-402	Bronze / Brass	3/4	DN 20	X			75 - 150	5.2 - 10.3	250°F	121.1°C
18C-400	Bronze / Brass	1/2 - 3/4	DN 15 - 20	X			125 - 175	8.61 - 12.1	210°F	98.9°C
18C-500	Bronze / Stainless	3/4 - 2	DN 20 - 50	X			75 - 150	5.2 - 10.3	210°F	98.9°C
ASME Section VIII Air / Gases										
15	Brass	1/4 - 1	DN 8 - 25	X		X	15 - 250	1.0 - 17.2	325°F	162.8°C
19M	Bronze / Brass	1/2 - 2-1/2	DN 15 - 65	X		X	8 - 300	0.55 - 20.7	406°F	207.7°C
19K	Bronze / Brass	1/2 - 2-1/2	DN 15 - 65	X		X	15 - 300	1.0 - 20.7	406°F	207.7°C
19L	Bronze / Stainless	1/2 - 2-1/2	DN 15 - 65	X		X	15 - 300	1.0 - 20.7	406°F	207.7°C
19S	Bronze / Stainless	1/2 - 2-1/2	DN 15 - 65	X		X	8 - 300	0.55 - 20.7	422°F	216.7°C
29	Bronze / Brass	3/8 - 1-1/4	DN 10 - 32	X		X	30 - 200	2.0 - 13.8	406°F	207.7°C
119	Cast Iron / Stainless	1-1/2 - 6	DN 40 - 150	X	X	X	8 - 250	0.55 - 17.2	450°F	232.2°C
510	Bronze / Brass	1/2 - 2	DN 15 - 50	X		X	8 - 300	0.55 - 20.7	406°F	207.7°C
520	Bronze / Stainless	1/2 - 2	DN 15 - 50	X		X	8 - 1200	0.55 - 82.7	422°F	216.7°C
530	Steel / Stainless	1/2 - 2	DN 15 - 50	X	X	X	8 - 1200	0.55 - 82.7	800°F	426.7°C
540	Stainless / Stainless	1/2 - 2	DN 15 - 50	X	X	X	8 - 1200	0.55 - 82.7	800°F	426.7°C
ASME Section VIII Steam										
10-322	Brass	3/4	DN 20	X		X	15 - 60	1.0 - 4.1	325°F	162.8°C
10-512	Brass	1/2	DN 15	X		X	9 - 60	0.62 - 4.1	325°F	162.8°C
19M	Bronze / Brass	1/2 - 2-1/2	DN 15 - 65	X		X	8 - 250	0.55 - 17.2	406°F	207.7°C
19K	Bronze / Brass	1/2 - 2-1/2	DN 15 - 65	X		X	15 - 250	1.0 - 17.2	406°F	207.7°C
19L	Bronze / Stainless	1/2 - 2-1/2	DN 15 - 65	X		X	15 - 250	1.0 - 17.2	406°F	207.7°C
19S	Bronze / Stainless	1/2 - 2-1/2	DN 15 - 65	X		X	8 - 300	0.55 - 20.7	422°F	216.7°C
29	Bronze / Brass	3/8 - 1-1/4	DN 10 - 32	X		X	30 - 200	2.0 - 13.8	406°F	207.7°C
119	Cast Iron / Stainless	1-1/2 - 6	DN 40 - 150	X	X	X	8 - 250	0.55 - 17.2	450°F	232.2°C
510	Bronze / Brass	1/2 - 2	DN 15 - 50	X		X	8 - 250	0.55 - 17.2	406°F	207.7°C
520	Bronze / Stainless	1/2 - 2	DN 15 - 50	X		X	8 - 300	0.55 - 20.7	422°F	216.7°C
530	Steel / Stainless	1/2 - 2	DN 15 - 50	X	X	X	8 - 900	0.55 - 62.1	800°F	426.7°C
540	Stainless / Stainless	1/2 - 2	DN 15 - 50	X	X	X	8 - 900	0.55 - 62.1	800°F	426.7°C
ASME Section VIII Liquid										
510	Bronze / Brass	1/2 - 2	DN 15 - 50	X		X	8 - 300	0.55 - 20.7	406°F	207.7°C
520	Bronze / Stainless	1/2 - 2	DN 15 - 50	X		X	8 - 1200	0.55 - 82.7	422°F	216.7°C
530	CS / Stainless	1/2 - 2	DN 15 - 50	X	X	X	8 - 1200	0.55 - 82.7	800°F	426.7°C
540	Stainless / Stainless	1/2 - 2	DN 15 - 50	X	X	X	8 - 1200	0.55 - 82.7	800°F	426.7°C
Non-Code, Vacuum & Miscellaneous Products										
14-400, 14-500	Low Pressure Air	2 - 3	DN 50 - 80	X			4 - 22	0.3 - 1.52	400°F	204.4°C
14-600	Vacuum Relief	2 - 3	DN 50 - 80	X			8 - 30 HG	203 - 762 mm. HG	400°F	204.4°C
16-200	Liquids	1/2	DN 15	X			30 - 80	2.1 - 12.4	120°F	48.9°C
16-501	Adj. Liquid Bypass	1/2	DN 15	X			50 - 600	0 - 41.4	200°F	93.3°C
16-503, 16-504	Calibrated Liquid Relief	1/2 - 3/4	DN 15 - 20	X			50 - 175	3.4 - 12.1	200°F	93.3°C
Drip Pan Elbows	Steam Discharge	3/4 - 8	DN 20 - 200	X	X		N/A	N/A	450°F	232.2°C



10 (RVW) SERIES

HOT WATER BOILER SAFETY RELIEF



Brass/bronze safety relief valves protect ASME Section IV hot water heating boilers and hydronic heating systems. High capacity design features corrosion resistant construction. Brass, satin or polished chrome finishes available.

ASME Section IV

- Inlet Size 3/4" - Outlet - 3/4" & 1"
- Factory Set Pressure 20-150 psi
- Maximum Temperature Service: 250°F

APPLICATIONS

- Ideal for Use With Hot Water Boilers and Hydronic Heating Systems

FEATURES

- Pressures From 20 to 150 psig
- Registered in all Canadian Provinces and Territories, CRN #0G8547.5C
- Stainless Steel Springs Standard
- 10-624/634 are Ideal for Use in Various Plumbing Systems, Commercial Boiler Applications and Swimming Pool Heaters
- 10-418/417 are Ideal for Use in Swimming Pool Heater Applications

OPTIONS

- Models 10-104 and 10-301 are Available with Optional Satin or Polished Chrome Finish
- 10-321 Available in Polished Chrome Only

AVAILABLE CONFIGURATIONS

Model Number	Size(in./mm.)		Certified Pressure Range psig	Height (in./mm.)	Wt./100 (lbs./kg.)
	Inlet NPT	Outlet NPT			
10-102	3/4F	1F	20-60	3.94	105
	20 F	25 F		100	47.7
10-104	3/4 M	1 F	20-60	3.75	109
	20 M	25 F		95	49.5
10-301	3/4 M	3/4 F	20-60	3.75	114
	20 M	20 F		95	51.8
10-303	3/4 F	3/4 F	20-60	3.94	115
	20 F	20 F		100	52.3
10-321	3/4 M	3/4 F	20-60	3.75	123
	20 M	20 F		95	55.9
10-407	3/4 M	3/4 F	30	3	62
	20 M	20 F		76	28.2
10-408	3/4 F	3/4 F	30	2.75	65
	20 F	20 F		70	29.5
10-417	3/4 M	3/4 F	20-80	3	62
	20 M	20 F		76	28.1
10-418	3/4 F	3/4 F	20-80	2.75	65
	20 F	20 F		70	29.5
10-624	3/4 M	3/4 F	30-150	4.62	106
	20 M	20 F		117	48.2
10-634	3/4 F	3/4 F	30-150	4.62	106
	20 F	20 F		117	48.2



10-102
10-303



10-104
10-301



10-321

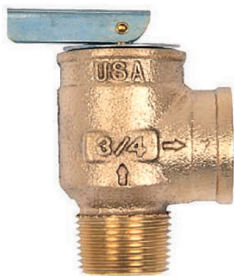

10-407
10-417



10-408
10-418



10-624
10-634 OEM



10 (RVW) SERIES

HOT WATER BOILER SAFETY RELIEF

ASME SECTION IV - HOT WATER

British thermal units per hour (kilocalories per hour) at 10% overpressure. National Board Certified. Ratings are 90% of actual.

US CUSTOMARY UNITS BTU/Hr.

METRIC UNITS Kcal/Hr.

Model No.	10-102 10-104	10-301 10-303	10-321	10-407 10-408	10-417 10-418	10-624 10-634	Model No.	10-102 10-104	10-301 10-303	10-321	10-407 10-408	10-417 10-418	10-624 10-634
Set Pressure psig							Set Pressure barg						
5*	-	225,000	175,000	-	-	-	0.34	-	57	44	-	-	-
10*	-	295,000	230,000	-	-	-	0.69	-	74	58	-	-	-
15	-	365,000	285,000	-	-	-	1.03	-	92	72	-	-	-
20	545,000	420,000	325,000	-	377,000	-	1.38	137	106	82	-	95	-
25	625,000	485,000	375,000	-	427,000	-	1.72	158	122	95	-	108	-
30	710,000	550,000	425,000	535,000	477,000	689,000	2.07	179	139	107	135	120	174
35	790,000	610,000	475,000	-	532,000	769,000	2.41	199	154	120	-	134	194
40	870,000	675,000	525,000	-	587,000	848,000	2.76	219	170	132	-	148	214
45	955,000	740,000	575,000	-	642,000	928,000	3.10	241	187	145	-	162	234
50	1,035,000	805,000	625,000	-	697,000	1,007,000	3.45	261	203	158	-	176	254
55	1,115,000	870,000	675,000	-	752,000	1,087,000	3.80	281	219	170	-	190	274
60	1,200,000	935,000	725,000	-	807,000	1,166,000	4.14	303	236	183	-	204	294
65	-	-	-	-	862,000	1,246,000	4.48	-	-	-	-	217	314
70	-	-	-	-	917,000	1,325,000	4.83	-	-	-	-	231	334
75	-	-	-	-	972,000	1,405,000	5.17	-	-	-	-	245	354
80	-	-	-	-	1,027,000	1,484,000	5.51	-	-	-	-	259	374
85	-	-	-	-	-	1,564,000	5.86	-	-	-	-	-	394
90	-	-	-	-	-	1,643,000	6.20	-	-	-	-	-	414
95	-	-	-	-	-	1,723,000	6.55	-	-	-	-	-	435
100	-	-	-	-	-	1,802,000	6.89	-	-	-	-	-	454
105	-	-	-	-	-	1,882,000	7.24	-	-	-	-	-	475
110	-	-	-	-	-	1,961,000	7.58	-	-	-	-	-	495
115	-	-	-	-	-	2,041,000	7.93	-	-	-	-	-	515
120	-	-	-	-	-	2,120,000	8.27	-	-	-	-	-	535
125	-	-	-	-	-	2,199,000	8.62	-	-	-	-	-	555
130	-	-	-	-	-	2,279,000	8.96	-	-	-	-	-	575
135	-	-	-	-	-	2,358,000	9.31	-	-	-	-	-	595
140	-	-	-	-	-	2,438,000	9.65	-	-	-	-	-	615
145	-	-	-	-	-	2,517,000	10.00	-	-	-	-	-	635
150	-	-	-	-	-	2,597,000	10.34	-	-	-	-	-	655

* Pressure settings below 15 psi are non-ASME Code.

P/N SUFFIX KEY

Set Pressure psig	Exterior Finish		
	Plain Brass	Satin Chrome	Polished Chrome
20	-02	-41	-67
22	-03	-42	-68
25	-04	-43	-69
30	-05	-44	-70
35	-06	-45	-71
40	-07	-46	-72
43	-08	-47	-73
45	-09	-48	-74
50	-10	-49	-75
55	-11	-50	-76
60	-12	-51	-77
65	-13		
70	-14		
75	-15		
80	-16		

ORDERING CODE

Use two-digit suffix number to indicate set pressure and body finish. Suffix for 10-624 / 10-634 models is actual set pressure in psig.

EXAMPLE:

10-301-44 = 3/4" 10-301 set @ 30 psig, satin chrome finish.

10-624-125 = 3/4" 10-624 set @ 125 psig (plain bronze finish only)

NOTE:

- Model 10-321 available in polished chrome finish only.
- All other models are furnished with plain bronze finish.
- Model 10-104 and 10-301 available with optional satin or polished chrome finish.



10-322 (RVS32) & 10-512 (RVS52) SERIES

OEM STYLE STEAM SAFETY RELIEF



10-512



10-322

National Board capacity-certified safety valves; brass body with optional satin or polished chrome finish. Protects against excess pressure from thermal expansion and steam caused by failure of BTU input controls.

ASME Section VIII

- Sizes 1/2" and 3/4"
- Factory Set Pressures 15 to 60 psig @ 312°F max
- National Board Certified Capacity

APPLICATIONS

- Ideally suited for OEM applications such as steam carpet and jewelry cleaners, autoclaves, sterilizers, commercial pressure cookers, steam jacketed kettles, dental equipment, coffee makers and similar equipment.

FEATURES

- Stainless Steel Springs
- Small Physical Size
- Discharge Capacities to 725 lbs./hr.
- Soft Seating for Exceptional Seat Tightness
- Pressure Settings 15 to 60 psig
- 10-322 in Polished Chrome Only (10-322-P)
- CRN 068547.5C, Registered in all Canadian Provinces and Territories
- More Descriptive Model Numbering System

OPTIONS

(Model 10-512 Only)

- Satin or Polished Chrome Finish
- Stainless Steel Wetted Trim
- BSP Pipe Connections
- CE/PED Compliance

AVAILABLE CONFIGURATIONS

Model Number	Size (in./mm.)		Set Pressure Range psig	Height (in./mm.)	Wt./100 (lbs./kg.)
	Inlet NPT	Outlet NPT			
10-322	3/4 M	3/4 F	20-60	3.75	128
	20	20		95	58.2
10-512	1/2 M	1/2 F	15-60	2.62	58
	15	15		67	26.4

P/N SUFFIX KEY

Set Pressure psig	*Certified Capacities	
	10.322 lbs.hr.	15.512 lbs.hr.
15	-	151
20	325	178
25	375	205
30	425	232
35	475	258
40	525	285
45	575	312
50	625	339
55	675	366
60	725	392

* ASME (UV) Rating – 90% of actual capacity at 10% accumulation. Capacity in lbs. of saturated steam per hour.

PART NUMBER MATRIX

10 - X	-X	-XX	-X
MODEL AND SIZE (IN.)	FINISH	SET PRESSURE	OPTIONS
512 = 1/2 x 1/2 322 = 3/4 x 3/4	B = Plain Brass S = Satin Chrome P = Polished Chrome	Set Pressure in PSIG (2 Digits)	B = BSPP connections CE = PED/CE S = Stainless Steel Trim V = Viton® Seat X = Blank Outlet not Threaded

EXAMPLE:

10-322-P-20 = 3/4" 10-322 set @ 20 psig, polished chrome finish.

NOTE:

- Model 10-322 available in polished chrome finish only.
- Valves may be set for any pressure between 15 and 60 psig.



10-322 (RVS32)

OEM STYLE STEAM SAFETY RELIEF

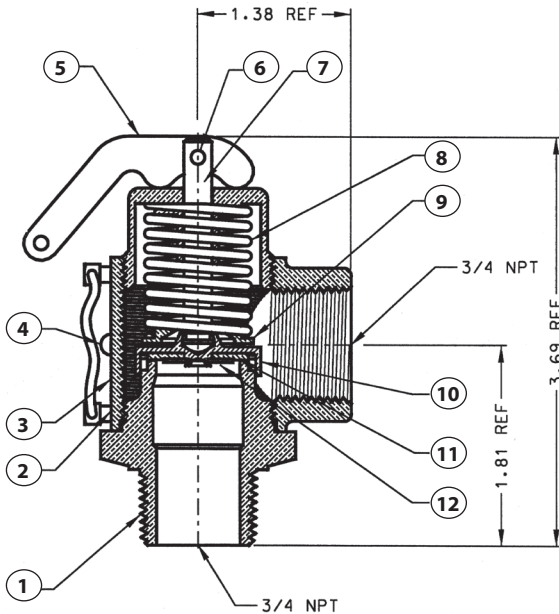

STANDARD MATERIAL LIST

1	NOZZLE	Brass, ASTM B-16
2	BODY	Brass, ASTM B-16
3	NAMEPLATE	Aluminum
4	DRIVE SCREW	Steel, Zinc Plated
5	HANDLE	Steel, Zinc Plated
6	COTTER PIN	Steel, Zinc Plated
7	STEM	Brass, ASTM B-16
8	SPRING	Stainless Steel
9	SPRING WASHER	Brass, ASTM B-16
10	DISC	Brass, ASTM B-16
11	SEAT	Teflon [®] Faced EPDM
12	WASHER	Brass, ASTM B-16

10-512 (RVS52)

OEM STYLE STEAM SAFETY RELIEF

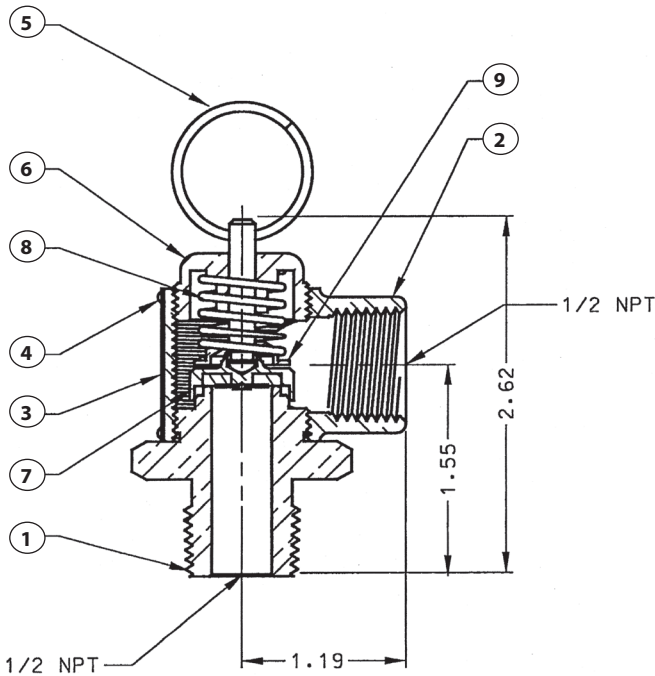

STANDARD MATERIAL LIST

1	NOZZLE	Brass, ASTM B-16
2	BODY	Brass, ASTM B-16
3	NAMEPLATE	Aluminum
4	DRIVE SCREW	Steel, Zinc Plated
5	PULL RING	Steel, Zinc Plated
6	CAP	Brass, ASTM B-16
7	DISC ASSEMBLY	Brass, Silicone
8	SPRING	Stainless Steel
9	SPRING WASHER	Brass, ASTM B-16

Model 10-512 available with optional stainless steel wetted trim. Nozzle, disc holder and disc washer are type 316 stainless steel.



10-600 (RVW) SERIES

HIGH CAPACITY HOT WATER BOILER SAFETY RELIEF



High-capacity heating system valves with female inlet and standard or expanded female outlet. Elevated seat for drainage of water away from seat area. Entire pressure range is National Board capacity certified.

ASME Section IV

- Inlet Sizes 3/4" to 2"
- Factory Set Pressures from 15-160 psig
- Maximum Temperature Service 250°F

APPLICATIONS

- Hot water heating boilers and hot water supply systems

FEATURES

- High BTU Capacity Rating
- Silicone Seat
- Fabric Reinforced Molded Diaphragm Isolates Spring from Water at all Times
- Bronze Body and Spring Cage
- Registered in Canadian Provinces and Territories, CRN #0G8547.5C
- Protects Against Excessive Water Pressure Due to Failure of Controls to Regulate BTU Input

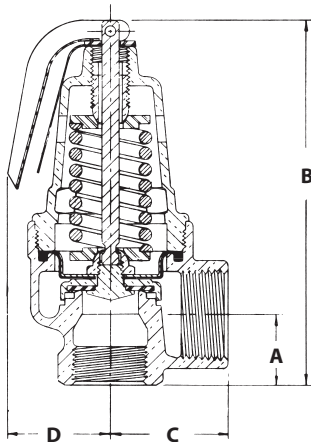

AVAILABLE CONFIGURATIONS

Model Number	Size(in./mm.)		Certified Pressure Range psig	Wt./100 (lbs./kg.)	Dimensions (in./mm.)			
	Inlet NPT	Outlet NPT			A	B	C	D
10-604	3/4F	3/4F	15-160	232	1.03	5.25	1.62	1.56
	20	20		105.2	26	133	41	39
10-614	3/4F	1 F	15-160	226	1.03	5.25	1.72	1.56
	20	25		102.5	26	133	43	39
10-605	1F	1F	15-160	410	1.25	6.69	2.00	2.00
	25	25		185.9	31	169	50	50
10-615	1 F	1-1/4F	15-160	390	1.25	6.69	2.00	2.00
	25	32		176.9	31	169	50	50
10-606	1-1/4F	1-1/4F	15-160	795	1.25	8.37	2.47	2.62
	32	32		360.5	31	212	63	67
10-616	1-1/4F	1-1/2F	15-160	755	1.25	8.37	2.47	2.62
	32	40		342.4	31	212	63	67
10-607	1-1/2F	1-1/2F	15-160	1100	2.00	10.75	2.75	3.12
	40	40		498.9	50	273	69	79
10-617	1-1/2F	2F	15-160	1145	2.00	10.75	2.75	3.12
	40	50		519.3	50	273	69	79
10-608	2F	2F	15-160	2375	2.19	14.00	3.69	3.50
	50	50		1077.1	55	355	93	88
10-618	2F	2-1/2F	15-160	2315	2.19	14.00	3.66	3.50
	50	65		1049.9	55	355	92	88

P/N SUFFIX KEY

Set Pressure psig	Suffix	Set Pressure psig	Suffix
15	-01	85	-17
20	-02	90	-18
22	-03	95	-19
25	-04	100	-20
30	-05	105	-21
35	-06	110	-22
40	-07	115	-23
43	-08	120	-24
45	-09	125	-25
50	-10	130	-30
55	-11	135	-31
60	-12	140	-32
65	-13	145	-33
70	-14	150	-34
75	-15	155	-35
80	-16	160	-36

ORDERING CODE

Use two-digit suffix number to indicate Inlet x Outlet size and set pressure.

EXAMPLE:

10-615-12 = 1"x 1-1/4" 10-610 set 60 psig

10-608-05 = 2"x 2" 10-600 set 30 psig



10-600 (RVW) SERIES

HIGH CAPACITY HOT WATER BOILER SAFETY RELIEF

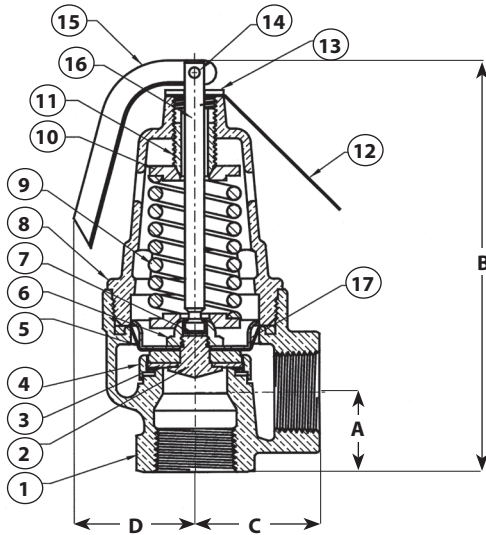

STANDARD MATERIAL LIST

1	BODY	Bronze Alloy C84400
2	SEAT INSERT	Brass, ASTM B-16
3	SEAT	Silicone
4	DISC	Brass ASTM B-16
5	DIAPHRAGM	Fabric Reinforce EPDM
6	STEM NUT	Steel, Plated
7	SPACER	Silicone
8	CAP	Bronze Alloy C84400
9	SPRING	PLATED ASTM A228
10	SPRING WASHER	AISI 12L14 Steel
11	ADJ. SCREW	Brass, ASTM B-16
12	NAMEPLATE	Aluminum
13	LIFT WASHER	Steel, Plated
14	HANDLE RIVET	Steel, Plated
15	LIFT HANDLE	Steel, Plated
16	STEM NUT	Steel, Plated
17	DIAPHRAGM RET.	Steel, Plated

ASME SECTION IV HOT WATER

British thermal units per hour (kilocalories per hour) at 10% overpressure. National Board Certified. Ratings are 90% of actual.

US CUSTOMARY UNITS BTU/Hr.

METRIC UNITS Kcal/Hr.

Model No.	10-604 3/4 x 3/4	10-605 1 x 1	10-606 1-1/4 x 1-1/4	10-607 1-1/2 x 1-1/2	10-608 2 x 2	Model No.	10-604 20 x 20	10-605 25 x 25	10-606 32 x 32	10-607 40 x 40	10-608 50 x 50
Set Pressure psig	Set Pressure barg										
15	541,000	876,000	1,515,000	2,061,000	3,397,000	1.03	136	221	382	520	857
20	636,000	1,030,000	1,782,000	2,424,000	3,996,000	1.38	160	260	449	611	1,008
25	732,000	1,185,000	2,049,000	2,788,000	4,595,000	1.72	185	299	517	703	1,159
30	827,000	1,339,000	2,316,000	3,151,000	5,193,000	2.07	209	351	584	795	1,310
35	923,000	1,493,000	2,583,000	3,514,000	5,792,000	2.41	233	377	651	886	1,461
40	1,018,000	1,648,000	2,850,000	3,878,000	6,391,000	2.76	257	416	719	978	1,612
45	1,113,000	1,802,000	3,117,000	4,241,000	6,990,000	3.10	281	454	786	1,070	1,763
50	1,209,000	1,956,000	3,384,000	4,604,000	7,589,000	3.45	305	493	853	1,161	1,914
55	1,304,000	2,111,000	3,651,000	4,968,000	8,188,000	3.79	329	532	921	1,253	2,065
60	1,399,000	2,265,000	3,918,000	5,331,000	8,786,000	4.14	353	571	988	1,344	2,219
65	1,495,000	2,420,000	4,185,000	5,694,000	9,385,000	4.48	377	610	1,055	1,436	2,367
70	1,590,000	2,574,000	4,453,000	6,058,000	9,984,000	4.83	401	649	1,123	1,528	2,518
75	1,686,000	2,728,000	4,720,000	6,421,000	10,583,000	5.17	425	688	1,190	1,619	2,669
80	1,781,000	2,883,000	4,987,000	6,784,000	11,182,000	5.51	449	727	1,258	1,711	2,820
85	1,876,000	3,037,000	5,254,000	7,148,000	11,780,000	5.86	473	766	1,325	1,803	2,971
90	1,972,000	3,192,000	5,521,000	7,511,000	12,379,000	6.20	497	805	1,393	1,894	3,122
95	2,067,000	3,346,000	5,788,000	7,874,000	12,978,000	6.55	521	844	1,560	1,986	3,273
100	2,162,000	3,500,000	6,055,000	8,238,000	13,577,000	6.89	545	883	1,527	2,076	3,424
105	2,258,000	3,655,000	6,322,000	8,601,000	14,176,000	7.24	569	922	1,594	2,169	3,575
110	2,353,000	3,809,000	6,589,000	8,964,000	14,775,000	7.58	593	961	1,662	2,261	3,726
115	2,449,000	3,963,000	6,856,000	9,327,000	15,373,000	7.93	618	999	1,729	2,352	3,877
120	2,544,000	4,118,000	7,123,000	9,691,000	15,972,000	8.27	642	1,039	1,796	2,444	4,028
125	2,639,000	4,272,000	7,390,000	10,054,000	16,571,000	8.62	666	1,077	1,864	2,536	4,179
130	2,735,000	4,427,000	7,657,000	10,417,000	17,170,000	8.96	690	1,116	1,931	2,627	4,330
135	2,830,000	4,581,000	7,924,000	10,781,000	17,769,000	9.31	714	1,155	1,998	2,719	4,481
140	2,925,000	4,735,000	8,191,000	11,144,000	18,368,000	9.65	738	1,194	2,066	2,811	4,632
145	3,021,000	4,890,000	8,458,000	11,507,000	18,966,000	10.00	762	1,233	2,133	2,902	4,783
150	3,116,000	5,044,000	8,725,000	11,871,000	19,565,000	10.34	786	1,272	2,200	2,994	4,934
155	3,212,000	5,199,000	8,992,000	12,234,000	20,164,000	10.69	810	1,311	2,268	3,085	5,085
160	3,307,000	5,353,000	9,260,000	12,597,000	20,763,000	11.03	834	1,350	2,335	3,177	5,236



10-610 (RVW) SERIES

HIGH CAPACITY HOT WATER BOILER SAFETY RELIEF

ASME SECTION IV - HOT WATER

British thermal units per hour (kilocalories per hour) at 10% overpressure. National Board Certified. Ratings are 90% of actual.

US CUSTOMARY UNITS BTU/Hr.

METRIC UNITS Kcal/Hr.

Model No.	10-614 3/4 x 1	10-615 1 x 1-1/4	10-616 1-1/4 x 1-1/2	10-617 1-1/2 x 2	10-618 2 x 2-1/2	Model No.	10-614 20 x 25	10-615 25 x 32	10-616 32 x 40	10-617 40 x 50	10-618 50 x 65
Set Pressure psig						Set Pressure barg					
15	635,000	1,027,000	1,777,000	2,417,000	3,984,000	1.03	160	259	448	610	1,005
20	746,000	1,208,000	2,090,000	2,843,000	4,686,000	1.38	188	305	527	717	1,182
25	858,000	1,389,000	2,403,000	3,270,000	5,389,000	1.72	216	350	606	825	1,359
30	970,000	1,570,000	2,716,000	3,696,000	6,091,000	2.07	245	396	645	932	1,536
35	1,082,000	1,751,000	3,030,000	4,122,000	6,793,000	2.41	273	442	765	1,040	1,713
40	1,194,000	1,933,000	3,343,000	4,548,000	7,496,000	2.76	301	488	843	1,147	1,890
45	1,306,000	2,114,000	3,656,000	4,974,000	8,198,000	3.10	329	533	922	1,254	2,067
50	1,418,000	2,295,000	3,969,000	5,400,000	8,900,000	3.45	358	579	932	1,362	2,244
55	1,529,000	2,476,000	4,283,000	5,826,000	9,603,000	3.79	386	624	1,080	1,469	2,422
60	1,641,000	2,657,000	4,596,000	6,252,000	10,305,000	4.14	414	670	1,159	1,577	2,599
65	1,753,000	2,838,000	4,909,000	6,679,000	11,007,000	4.48	442	716	1,238	1,684	2,776
70	1,865,000	3,019,000	5,222,000	7,105,000	11,710,000	4.83	470	761	1,317	1,792	2,953
75	1,977,000	3,200,000	5,535,000	7,531,000	12,412,000	5.17	498	807	1,396	1,899	3,130
80	2,089,000	3,381,000	5,849,000	7,957,000	13,114,000	5.51	527	827	1,475	2,007	3,307
85	2,201,000	3,562,000	6,162,000	8,383,000	13,817,000	5.86	555	898	1,554	2,114	3,485
90	2,313,000	3,743,000	6,475,000	8,809,000	14,519,000	6.20	583	944	1,633	2,222	3,662
95	2,424,000	3,924,000	6,788,000	9,235,000	15,221,000	6.55	611	990	1,712	2,329	3,839
100	2,536,000	4,105,000	7,101,000	9,661,000	15,924,000	6.89	640	1,035	1,791	2,437	4,016
105	2,648,000	4,286,000	7,415,000	10,088,000	16,626,000	7.24	668	1,081	1,870	2,544	4,193
110	2,760,000	4,468,000	7,728,000	10,514,000	17,328,000	7.58	696	1,127	1,949	2,652	4,370
115	2,872,000	4,649,000	8,041,000	10,940,000	18,031,000	7.93	724	1,172	2,028	2,759	4,547
120	2,984,000	4,830,000	8,354,000	11,366,000	18,733,000	8.27	752	1,218	2,107	2,866	4,724
125	3,096,000	5,011,000	8,668,000	11,792,000	19,435,000	8.62	781	1,264	2,186	2,974	4,901
130	3,207,000	5,192,000	8,981,000	12,218,000	20,138,000	8.96	809	1,309	2,265	3,081	5,079
135	3,319,000	5,373,000	9,294,000	12,644,000	20,840,000	9.31	837	1,355	2,344	3,189	5,256
140	3,431,000	5,554,000	9,607,000	13,070,000	21,543,000	9.65	865	1,401	2,423	3,296	5,433
145	3,543,000	5,735,000	9,920,000	13,497,000	22,245,000	10.00	893	1,446	2,502	3,404	5,610
150	3,655,000	5,916,000	10,234,000	13,923,000	22,947,000	10.34	922	1,492	2,581	3,511	5,787
155	3,767,000	6,097,000	10,547,000	14,349,000	23,650,000	10.69	950	1,538	2,660	3,619	5,964
160	3,879,000	6,278,000	10,860,000	14,775,000	24,352,000	11.03	978	1,583	2,739	3,726	6,141



12-200 (RVS12) SERIES

LOW PRESSURE STEAM HEATING BOILER SAFETY

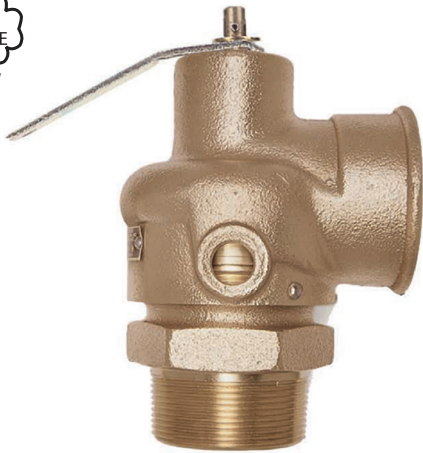

Medium capacity safety valves protect ASME Section IV low pressure steam heating boilers. Cast bronze, full nozzle design features PTFE faced elastomer soft seating for dependable operation. Ideal for OEM applications.

ASME Section IV

- Sizes 2", 2-1/2" and 3"
- Factory Set Pressures 5-15 psi

APPLICATIONS

- Medium and Large Commercial and Industrial Steam Heating and Processing Boilers

FEATURES

- All Bronze Construction
- PTFE-Coated O-Ring Seat Seal
- 3/8" NPT Side Tapping for Drain
- Rust-Proofed Steel Spring
- Top Guided, High Capacity Design
- Registered in all Canadian Provinces and Territories, CRN #0G8547.5C
- National Board Certified at 15 psig

AVAILABLE CONFIGURATIONS

Model Number	Size (in./mm.)		Wt./Ea. (lbs./kg.)	Dimensions (in./mm.)			
	Inlet NPT	Outlet NPT		A	B	C	D
12-205	2M	2F	5.1	6.00	3.75	2.62	4.00
	50	50	2.3	152	95	67	102
12-206	2-1/2M	2-1/2F	8.4	8.50	5.25	3.06	4.00
	65	65	3.8	216	133	78	102
12-208	3M	3F	11.6	9.50	6.00	3.75	4.00
	80	80	5.3	241	152	95	102

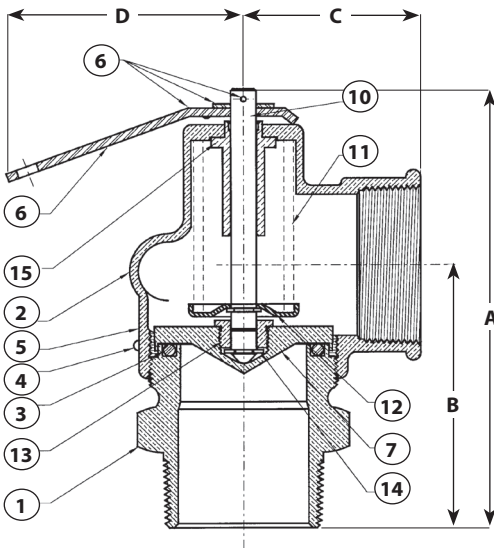

STANDARD MATERIAL LIST

Item	Part Name	Material
1	NOZZLE	Bronze, ASTM B584
2	BODY	Bronze, ASTM B584
3	O-RING	Teflon® Coated EPDM
4	DRIVE SCREW	AISI 1010 Plated CR Steel
5	NAMEPLATE	Aluminum
6	HANDLE ASSEMBLY	Steel, Plated
7	DISC	Brass, ASTM B-16
10	STEM	Brass, ASTM B-16
11	SPRING	Stainless Steel
12	SPR. WASHER	AISI 1010 Plated CR Steel
13	STEM NUT	Brass, ASTM B-16
14	RETAINER RING	Brass, ASTM B-16
15	GUIDE	Brass, ASTM B-16

P/N SUFFIX KEY

Set Pressure psig	Suffix
5	-03
6	-04
8	-05
10	-06
12	-07
15	-08

ORDERING CODE

Use two-digit suffix number to indicate set pressure and body finish.

EXAMPLE:

12-205-08 = 2" 12 Series set 15 psig



13 (RVS13) SERIES

LOW PRESSURE STEAM HEATING BOILER SAFETY



ASME Section IV bronze safety valves protect small to medium low pressure steam heating boilers. Three design configurations feature top guiding and raised seating area for extended service life. Available top and side discharge models.

ASME Section IV

- Inlet Sizes 3/4" to 2"
- Factory Set Pressures from 5-15 psig

APPLICATIONS

- Low Pressure Steam Heating and Supply Boilers

FEATURES

- Flat Seat, PTFE Faced Disc for Positive Seal
- Standard Set Pressure of 15 psig
- Positive Drainage of Condensate from Seat Area
- No. 13-101 is Top Outlet Discharge
- Registered in all Canadian Provinces and Territories, CRN #0G8547.5C
- ASME and National Board Certified at 15 psig

OPTIONS

- Satin or Polished Chrome Finishes

AVAILABLE CONFIGURATIONS

Model Number	Size (in./mm.)		Wt./100 (lbs./kg.)	Dimensions (in./mm.)			
	Inlet NPT	Outlet NPT		A	B	C	D
13-101	3/4 M	Top	64	2.87	0.94	1.25	—
	20		29.0	73	23	31	—
13-211	3/4 M	3/4 F	107	1.81	3.69	1.44	1.41
	20	20	48.5	46	93	36	35
13-202	1 M	1 F	110	2.06	3.87	1.53	1.41
	25	25	49.9	52	98	39	35
13-213	1-1/4 M	1-1/2 F	218	2.53	4.50	1.87	1.50
	32	40	98.9	64	114	47	38
13-214	1-1/2 M	2 F	320	3	5.25	2.19	1.81
	40	50	145.1	76	133	55	46
13-511	3/4 M	3/4 F	62	1.69	3.25	1.19	1.25
	20	20	28.1	42	82	30	31
13-512	3/4 F	3/4 F	59	1.19	2.75	1.19	1.25
	20	20	26.8	30	69	30	31

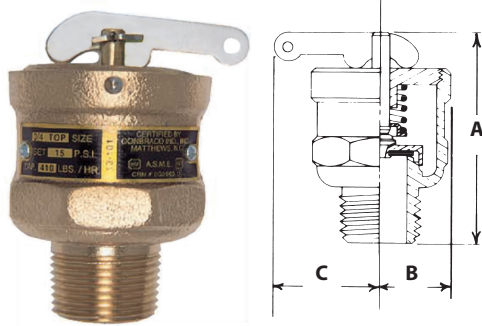

13-101

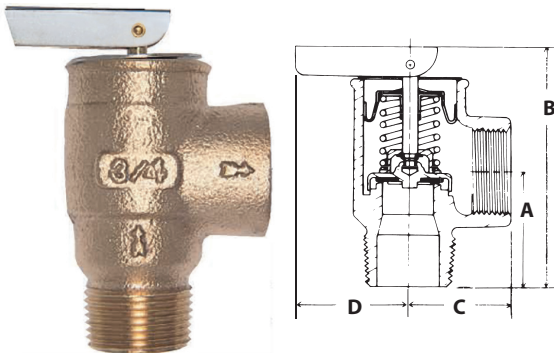

13-511

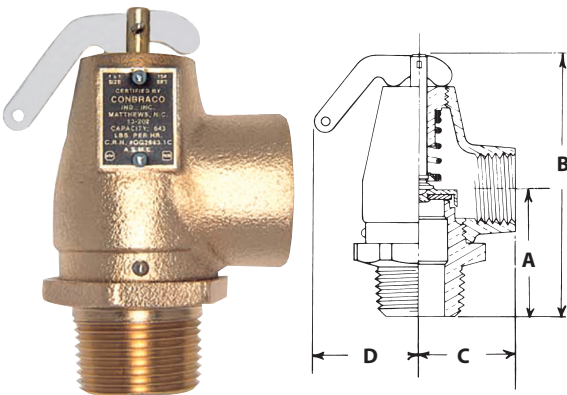

13-200

PART NUMBER MATRIX

13 - XXX	-X	-XX	-X
MODEL	FINISH	SET PRESSURE	OPTIONS
101 = 3/4" M x Top	B = Plain Brass	Set Pressure in PSIG (2 Digits)	A = Air Service (Non-ASME)
211 = 3/4" M x 3/4" F	S = Satin Chrome*		
202 = 1" M x 1" F	P = Polished Chrome*		
213 = 1-1/4" M x 1-1/2" F	*Available on select models		
214 = 1-1/2" M x 2" F			
511 = 3/4" M x 3/4" F			
512 = 3/4" F x 3/4" F			

EXAMPLE:
13-511-B15 = 3/4" 13-511 set at 15 psig



14-200 (RSV14) SERIES

LOW PRESSURE STEAM HEATING SAFETY

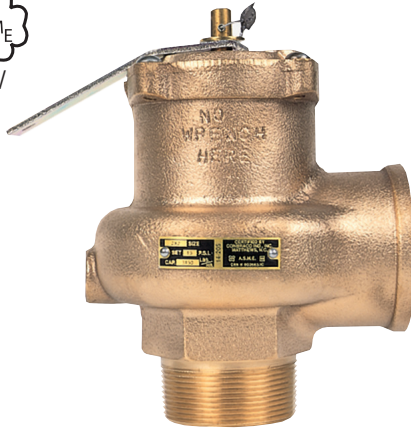

ASME Section IV

- Sizes 2", 2-1/2" and 3"
- Factory Set Pressures 5-15 psi

APPLICATIONS

- The 14 Series is an ASME Section IV High Capacity Steam Safety Valve for Use With Medium and Large Size Commercial and Industrial Heating Boilers

FEATURES

- One Piece Body, All Bronze Construction
- Rust-Proofed Steel Spring
- Chrome Plated Seat, PTFE Coated Disc
- PTFE Coated EPDM O-Ring for Positive Seal
- 3/8" NPT Side Tapping for Drain Connection
- Valves are Capacity Certified by the National Board at 15 psig Only, in Accordance with ASME Boiler and Pressure Vessel Code Section IV
- Registered in all Canadian Provinces and Territories, CRN #0G8547.5C

OPTIONS

- (-G) Test Gag Available to Prevent the Valve from Opening During Hydrostatic Boiler Testing

AVAILABLE CONFIGURATIONS

Model Number	Size (in./mm.)		Wt./Ea. (lbs./kg.)	Dimensions (in./mm.)			
	Inlet NPT	Outlet NPT		A	B	C	D
14-205	2M	2F	8.4	3.00	7.12	3.12	4.00
	50M	50F	3.8	76	181	79	101
14-206	2-1/2M	2-1/2F	13.0	3.50	8.25	3.50	4.00
	65M	65F	5.9	88	209	88	101
14-207	3M	3F	17.0	4.12	9.37	3.87	4.00
	80M	80F	7.7	104	238	98	101

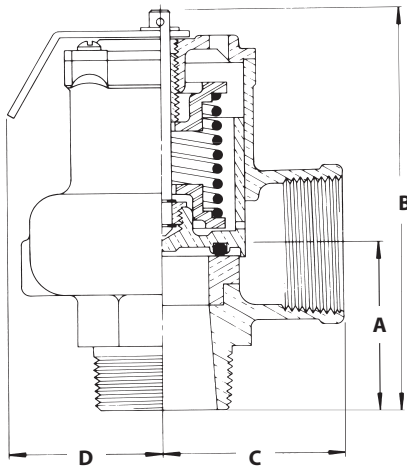

P/N SUFFIX KEY

Set Pressure psig	Suffix
5	-03
6	-04
8	-05
10	-06
12	-07
15	-08

ORDERING CODE

Use model number and two digit suffix number to indicate size and set pressure.

EXAMPLE:

14-206-08 = 2-1/2" valve set 15 psig

Note:

- ASME IV and NB certified capacities at 15 psi only
- Valves may be set for any pressure between 5 and 15 psi. Consult factory for set pressures not listed.
- To specify test gag option add "G" to suffix.



12, 13 & 14 SERIES

LOW PRESSURE STEAM HEATING BOILER SAFETY

ASME SECTION IV - STEAM

Pounds per hour (kilograms per hour) saturated steam at 33-1/3% overpressure. National Board Certified. Ratings are 90% of actual.

US CUSTOMARY UNITS BTU/Hr.

Model No. (in.)	12-205 2 x 2	12-206 2-1/2 x 2-1/2	12-208 3 x 3	13-101 3/4	13-202 1 x 1	13-211 3/4 x 3/4	13-213 1-1/4 x 1-1/2	13-214 1-1/2 x 2	13-511 13-512 3/4 x 3/4	14-205 2 x 2	14-206 2-1/2 x 2-1/2	14-207 3 x 3
Set Pressure psig												
5*	1,439	2,043	2,855	333	374	290	699	1,106	213	1,815	2,695	3,944
10*	1,969	2,786	3,478	372	509	383	950	1,503	310	2,483	3,686	5,394
15	2,500	3,529	4,100	410	643	475	1,200	1,900	407	3,150	4,676	6,843

METRIC UNITS Kcal/Hr.

Model No. (mm.)	12-205 50 x 50	12-206 65 x 65	12-208 80 x 80	13-101 20	13-202 25 x 25	13-211 20x20	13-213 32 x 40	13-214 40 x 50	13-511 13-512 20 x 20	14-205 50 x 50	14-206 65 x 65	14-207 80 x 80
Set Pressure barg												
0.34	653	927	1,295	151	170	131	317	502	97	823	1,222	1,789
0.69	893	1,264	1,577	169	231	174	431	682	141	1,126	1,672	2,447
1.03	1,134	1,601	1,860	186	292	215	544	862	185	1,429	2,121	3,103

*ASME Section IV and NB certified capacities at 15 psi only.

Valves may be set for any pressure between 5 and 15 psi. Consult factory for set pressures not listed.



14-400 & 14-500 (RVA14) SERIES

LOW PRESSURE AIR RELIEF

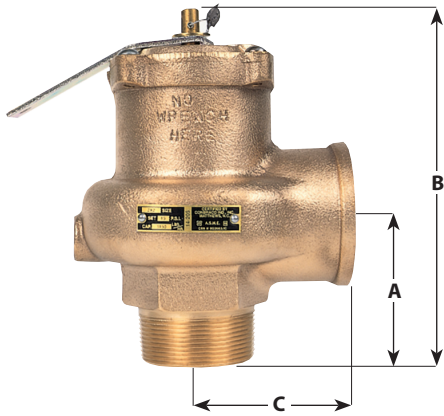

**14-400
w/ LIFT LEVER**

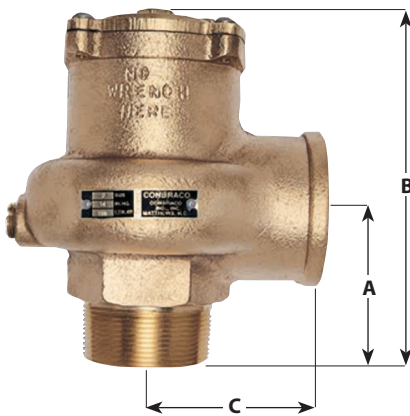

**14-500
PLAIN CAP**

High volume air relief valves designed for low pressure/high volume air and gas service. Rugged bronze construction features elastomer soft seating and TFE coated discs for dependable operation.

- Inlet Sizes 2", 2 1/2" and 3"
- Factory Set Pressures 4 to 22 psig @ 400°F max.

APPLICATIONS

- Non-ASME Code Air and Gas Service
- Low Pressure, High Volume Blowers and Compressors
- Bulk Hauling Tanks, Trailers and Rail Cars
- Powdered Solids / Bulk Handling
- Pneumatic Conveying Equipment

FEATURES

- Vibration Resistant Soft Seat is Standard
- Stainless Steel Spring
- One Piece Corrosion Resistant Bronze Body Design
- High Flow "Top-Guided" Design

OPTIONS

- Model 14-400 with Test Lever
- Model 14-500 with Plain Cap, Weather Resistant Sealed Body

AVAILABLE CONFIGURATIONS

Model Number	Size (in./mm.)	Dimensions (in./mm.)			Wt./Ea. (lbs./kg.)
		A	B	C	
14-X05	2 x 2	3	6-1/2	3-1/8	8.4
	50M x 50F	76	165	79	3.81
14-X06	2-1/2 x 2-1/2	3-1/2	7-5/8	3-1/2	12.5
	65M x 65F	89	194	89	5.7
14-X07	3 x 3	4-1/8	8-3/4	3-7/8	17.0
	80M x 80F	105	222	98	7.7

PART NUMBER MATRIX

14	-X	-XX	-X
SERIES NUMBER	BODY/CAP STYLE AND SERVICE	INLET CONNECTION	RELIEF PRESSURE
14 = Base Model No.	4 = Air Relief, with Test Lever 5 = Air Relief, Plain Cap	05 = 2" NPT 06 = 2 1/2" NPT 07 = 3" NPT	Set Pressure in PSIG (2 Digits)

EXAMPLE:

14-406 12 = 2-1/2" 14 Series air relief valve set at 12 psig, with lift lever
14-505-08 = 2" air relief valve set at 8 psig, with sealed cap



14-600 (RVA14) SERIES

VACUUM RELIEF

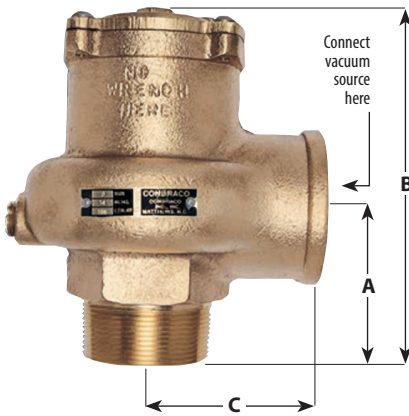

14-600

High flow vacuum relief valves feature one piece cast bronze bodies. Teflon coated discs and elastomer soft seating provide accurate and dependable operation.

- Connection Sizes 2", 2 1/2" and 3"
- Relief Settings 8" to 30" Hg @ 400°F max.

APPLICATIONS

- High Volume Vacuum Systems
- Bulk Hauling Tanks and Trailers
- Powdered Solids / Bulk Handling
- Pneumatic Conveying Equipment

FEATURES

- Weather Resistant Construction
- Elastomer Soft Seat is Vibration Resistant
- Stainless Steel Spring
- One Piece Corrosion Resistant Bronze Body Design
- High Capacity "Top-Guided" Design
- TFE / Chrome Plated Internals

AVAILABLE CONFIGURATIONS

Model Number	Size (in./mm.)	Dimensions (in./mm.)			Wt./Ea. (lbs./kg.)
		A	B	C	
14-605	2 x 2	3	6-1/2	3-1/8	8.4
	50M x 50F	76	165	79	3.81
14-606	2-1/2 x 2-1/2	3-1/2	7-5/8	3-1/2	11.8
	65M x 65F	89	194	89	5.4
14-607	3 x 3	4-1/8	8-3/4	3-7/8	16.3
	80M x 80F	105	222	98	7.4

PART NUMBER MATRIX

14	-6	-OX	-VXX
SERIES NUMBER	BODY/CAP STYLE AND SERVICE	INLET CONNECTION	RELIEF PRESSURE
14 = Base Model No.	6 = Vacuum Relief	05 = 2" NPT 06 = 2 1/2" NPT 07 = 3" NPT	Vacuum Relief Setting, HG "V" Prefix + Inches Mercury ("V" + 2 Digits)

EXAMPLE:

14-607-V14 = 3" vacuum relief valve set at 14 in. Hg



14-400 (RVA14) SERIES

LOW PRESSURE AIR RELIEF

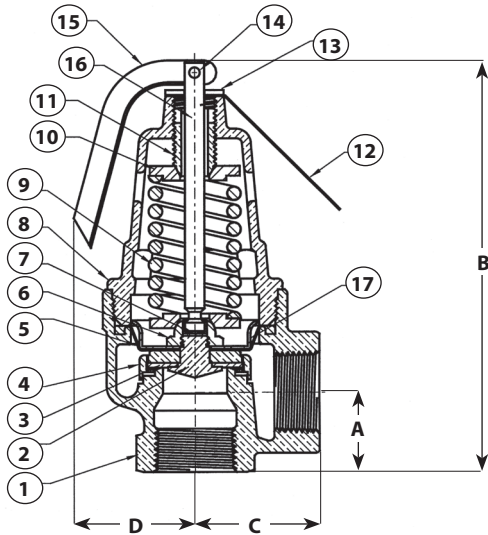

STANDARD MATERIAL LIST

1	NAMEPLATE	Aluminum
2	DRIVESCREWS (2)	Steel, Plated
3	SPRING	Stainless Steel
4	ADJUSTING SCREW	Brass, ASTM B-16
5	CAP SCREW (4)	Steel, Plated
6	SPRING WASHER	Brass, ASTM B-16
7	CAP	Bronze, ASTM B-584
8	SEAT-O-RING	Silicone
9	SEAT INSERT	Brass, ASTM B-16
10	DISC	Bronze, ASTM B-584
11	BODY	Bronze, ASTM B-584
12	FRICTION RING	EPDM
13	STEM NUT	Brass, ASTM B-16
14	STEM	Brass, ASTM B-16
15	RETAINING RING	Steel, Plated
16	LIFT WASHER	Steel, Plated
17	LIFT LEVER	Steel, Plated
18	ROLL PIN	Steel, Plated
19	PLUG	Brass, ASTM B-16
20	PLUG	Brass, ASTM B-16
21	CAP SEAL O-RING	Silicone

14-500 & 14-600 (RVA14) SERIES

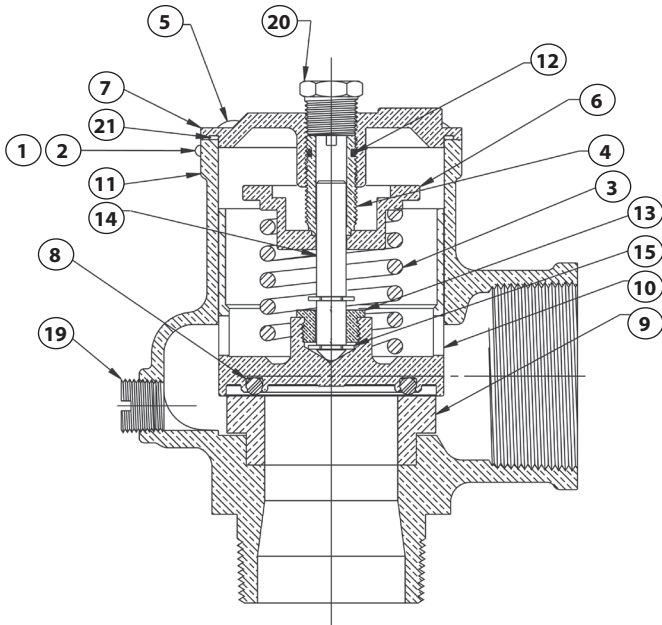

STANDARD MATERIAL LIST

1	NAMEPLATE	Aluminum
2	DRIVESCREWS (2)	Steel, Plated
3	SPRING	Stainless Steel
4	ADJUSTING SCREW	Brass, ASTM B-16
5	CAP SCREW (4)	Steel, Plated
6	SPRING WASHER	Brass, ASTM B-16
7	CAP	Bronze, ASTM B-584
8	SEAT-O-RING	Silicone
9	SEAT INSERT	Brass, ASTM B-16
10	DISC	Bronze, ASTM B-584
11	BODY	Bronze, ASTM B-584
12	FRICTION RING	EPDM
13	STEM NUT	Brass, ASTM B-16
14	STEM	Brass, ASTM B-16
15	RETAINING RING	Steel, Plated
16	LIFT WASHER	Steel, Plated
17	LIFT LEVER	Steel, Plated
18	ROLL PIN	Steel, Plated
19	PLUG	Brass, ASTM B-16
20	PLUG	Brass, ASTM B-16
21	CAP SEAL O-RING	Silicone



14-400 & 14-500 SERIES

LOW PRESSURE AIR RELIEF

NON-CODE AIR RELIEF CAPACITIES

Standard cubic feet per minute (normalized cubic meters per hour) of air at 10% overpressure.

US CUSTOMARY UNITS SCFM AIR

METRIC UNITS Nm³/Hr. AIR

Ordering Suffix	Model No. Size (in.) Area (in. ²)	14-405	14-406	14-407	Model No. Size (mm.) Area (cm ²)	14-405	14-406	14-407
		14-505 2 x 2 2.238	14-506 2-1/2 x 2-1/2 3.339	14-507 3 x 3 5.155		14-505 50 x 50 14.438	14-506 65 x 65 21.544	14-507 80 x 80 33.259
Set Pressure psig					Set Pressure barg			
-04	4	615	914	1338	.28	988	1469	2151
-05	5	651	967	1415	.34	1046	1554	2275
-06	6	687	1020	1492	.41	1104	1639	2398
-07	7	722	1072	1569	.48	1161	1724	2522
-08	8	758	1125	1646	.55	1218	1809	2646
-09	9	793	1178	1723	.62	1275	1893	2770
-10	10	829	1231	1801	.69	1332	1978	2894
-11	11	864	1283	1878	.76	1389	2063	3018
-12	12	900	1336	1955	.83	1446	2147	3142
-13	13	935	1389	2032	.90	1503	2232	3266
-14	14	971	1441	2109	.97	1560	2317	3390
-15	15	1006	1494	2186	1.03	1617	2402	3514
-16	16	1041	1547	2263	1.10	1673	2487	3638
-17	17	1076	1600	2340	1.17	1730	2572	3761
-18	18	1111	1653	2417	1.24	1786	2657	3885
-19	19	1146	1706	2494	1.31	1842	2742	4009
-20	20	1181	1756	2571	1.38	1899	2823	4133
-21	21	1216	1809	2648	1.45	1955	2907	4257
-22	22	1252	1861	2725	1.52	2012	2992	4381

14-600 SERIES

VACUUM RELIEF

VACUUM AIR RELIEF CAPACITIES

Standard cubic feet per minute (normalized cubic meters per hour) of air at 10% overpressure.

US CUSTOMARY UNITS SCFM AIR

METRIC UNITS Nm³/Hr. AIR

Ordering Suffix	Model No. Size (in.) Area (in. ²)	14-605	14-606	14-607	Model No. Size (mm.) Area (cm ²)	14-605	14-606	14-607
		2 x 2 2.238	2-1/2 x 2-1/2 3.339	3 x 3 5.155		50 x 50 14.438	65 x 65 21.544	80 x 80 33.259
Relief Setting (in. Hg)					Relief Setting (mm. Hg)			
V08	8	395	600	865	203	635	964	1390
V09	9	405	618	890	229	651	993	1431
V10	10	415	635	915	254	667	1021	1471
V11	11	421	642	927	279	676	1043	1509
V12	12	426	649	939	305	685	1050	1516
V13	13	430	653	943	330	691	1050	1516
V14	14	430	653	943	356	691	1050	1516
V15	15	430	653	943	381	691	1050	1516
V20	20	430	653	943	508	691	1050	1516
V25	25	430	653	943	635	691	1050	1516
V30	30	430	653	943	762	691	1050	1516



15 (RVA15) SERIES

AIR RELIEF

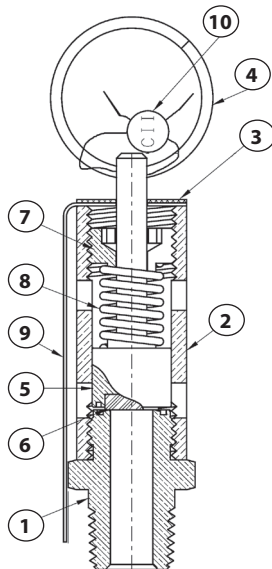

Rugged design 15 Series air relief valves provide dependable overpressure protection at an economical price. Top guided design features brass construction and resilient seating for superior performance. Widely used by OEM's and for aftermarket replacement.

ASME Section VIII

- Sizes 1/4" and 1"
- Factory Set Pressures 15 to 250 psig
- Maximum Temperature: 325° F

APPLICATIONS

- Ideal for a Wide Range of Air and Inert Gas Applications Including Compressors, Intercoolers, Dryers, Receivers, Control and Instrument Air Lines, and Pressurized Systems and Equipment

FEATURES

- National Board Certified 15 psig thru 250 psig
- Stainless Steel Springs
- Viton O-Ring Seat
- Registered in all Canadian Provinces and Territories, CRN #0G8547.5C
- ASTM B16 Brass Body
- RoHS Compliant Materials
- European Pressure Equipment Directive Compliant Option (CE/PED)

AVAILABLE CONFIGURATIONS

Model Number	Inlet Size (in./mm.)	Dimensions (in./mm.)		Wt./100 (lbs./kg.)
		A	B	
15-112	1/4 NPT	2.62	0.78	18.5
	8	66	20	8.4
15-115	3/8 NPT	3.25	1.12	42.2
	10	82	28	19.2
15-117	1/2 NPT	3.37	1.12	45.3
	15	85	28	20.6
15-118	3/4 NPT	4.06	1.21	58
	20	105	30	26.4
15-119	1 NPT	5.12	1.87	153
	25	130	47	69.5

PART NUMBER MATRIX

15-XXX	-X	-XXX	-XX
MODEL AND SIZE (IN.)	FINISH	SET PRESSURE	OPTIONS
112 = 1/4 NPT	B = Plain Brass	Set Pressure in PSIG	CE = PED/CE
115 = 3/8 NPT			Q = Performance (Calibration) Test Reports
117 = 1/2 NPT			
118 = 3/4 NPT			
119 = 1 NPT			

EXAMPLE:

15 117 B 165 = 1/2" 15 Series set at 165 psig.

STANDARD MATERIALS LIST

Part No.	Part Name	Material
1	NOZZLE	Brass, ASTM B-16
2	BODY	Brass, ASTM B-16
3	NAMEPLATE	Aluminum
4	PULL RING	Pltd. AISI 1018 CRS
5	DISC/STEM	Brass, ASTM B-16
6	SEAT	Viton
7	CAP	Brass, ASTM B-16
8	SPRING	ASTM A-227 Steel
9	INST. TAG	Paper
10	LEAD SEAL	Lead



15 (RVA15) SERIES

AIR RELIEF

ASME Section VIII - Air

Standard cubic feet per minute (normalized cubic meters per hour) of air at 10% overpressure. National Board Certified. Ratings are 90% of actual.

US CUSTOMARY UNITS SCFM AIR

METRIC UNITS Nm³/Hr. AIR

Model No. Size (in.)	15-112 1/4	15-115 & 117 3/8 & 1/2	15-118 3/4	15-119 1	Model No. Size (mm)	15-112 8	15-115 & 117 10 & 15	15-118 20	15-119 25
Set Pressure psig					Set Pressure barg				
15	24	60	107	222	1.03	39	96	172	357
20	28	70	124	256	1.38	45	112	199	411
25	32	79	140	290	1.72	51	127	225	466
30	35	88	156	323	2.07	57	141	251	519
35	39	98	174	361	2.41	63	157	280	580
40	43	109	193	398	2.76	69	175	310	640
45	47	119	211	435	3.10	75	191	339	699
50	51	128	229	473	3.45	82	206	368	760
55	55	139	247	510	3.79	88	223	397	820
60	60	149	265	547	4.14	96	239	426	879
65	64	159	283	584	4.48	103	255	455	939
70	68	170	301	622	4.83	109	273	484	1,000
75	72	179	319	659	5.17	116	288	513	1,059
80	76	190	337	696	5.51	122	305	542	1,119
85	80	200	355	734	5.86	129	321	571	1,180
90	84	210	373	771	6.20	135	337	600	1,239
95	88	220	391	808	6.55	141	354	628	1,299
100	92	230	409	845	6.89	148	370	657	1,358
105	96	241	427	883	7.24	154	387	686	1,419
110	100	251	445	920	7.58	161	403	715	1,479
115	104	261	463	957	7.93	167	419	744	1,538
120	108	271	481	995	8.27	174	436	773	1,599
125	112	281	499	1,032	8.62	180	452	802	1,659
130	116	292	517	1,069	8.96	186	469	831	1,718
135	120	302	535	1,106	9.31	193	485	860	1,778
140	124	312	553	1,144	9.65	199	501	889	1,839
145	129	322	571	1,181	10.00	207	518	918	1,898
150	133	332	589	1,218	10.34	214	534	947	1,958
155	137	342	607	1,256	10.69	220	550	976	2,019
160	141	353	625	1,293	11.03	227	567	1,005	2,078
165	145	363	644	1,330	11.38	233	583	1,035	2,138
170	149	373	662	1,368	11.72	239	600	1,064	2,199
175	153	383	680	1,405	12.06	246	616	1,093	2,258
180	157	393	698	1,442	12.41	252	632	1,122	2,318
185	161	403	716	1,479	12.75	259	648	1,151	2,377
190	165	414	734	1,517	13.10	265	665	1,180	2,439
195	169	424	752	1,554	13.44	272	681	1,209	2,498
200	173	432	770	1,591	13.79	278	694	1,238	2,557
205	177	444	788	1,629	14.13	285	714	1,267	2,619
210	181	454	806	1,666	14.48	291	730	1,296	2,678
215	185	464	824	1,703	14.82	298	746	1,325	2,738
220	189	475	842	1,740	15.17	305	763	1,353	2,797
225	194	484	860	1,778	15.51	311	778	1,382	2,858
230	198	495	878	1,815	15.86	318	796	1,411	2,918
235	202	505	896	1,852	16.20	324	812	1,440	2,977
240	206	515	914	1,890	16.55	331	828	1,469	3,038
245	210	525	932	1,927	16.89	337	844	1,498	3,098
250	214	535	950	1,964	17.24	344	860	1,527	3,157



16-200 (RVW16) SERIES

GENERAL PURPOSE PRESSURE RELIEF

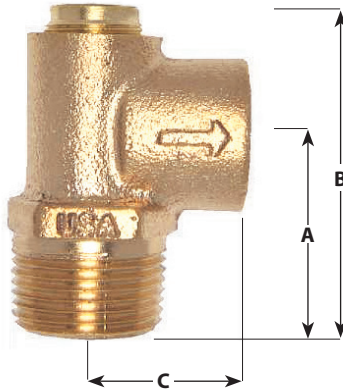

Pressure relief valves relieve excess pressure in cold water supply systems, storage tanks, well pumps. Also suitable for air, oil and other non-hazardous liquids.

FEATURES

- Standard Pressure Settings from 50 to 175 psi
- Cast Bronze Body, Stainless Steel Pprings
- Silicone Soft Seat Ensures Seat Tightness, Extended Service Life
- All Valves are 100% Factory Tested
- Maximum Recommended Service Temperature: 120°F
- Lead Free Option, Model 16LF is NSF/ANSI 372 Lead Free

AVAILABLE CONFIGURATIONS

Model Number	LF Model Number	Inlet Size (in./mm.)	Dimensions (in./mm.)			Wt./100 (lbs./kg.)
			A	B	C	
16-202	16LF-202	1/2 M X 1/2 F	1.41	2.12	1.00	33
		15 M x 15 F	36	54	25	15
16-203	16LF-203	3/4 M x 1/2 F	1.41	2.50	1.00	37.5
		20 M x 15 F	36	63	25	17

ORDERING CODE

Use model number and two digit suffix number to indicate size and set pressure.

P/N SUFFIX KEY

Set Pressure psig	Suffix
50	-01
75	-02
100	-03
125	-04
150	-05
175	-06

EXAMPLE:

16-202-03 = 1/2" model set at 100 psig

NOTE:

- Valves may be set for any pressure between 30 and 180 psi. Consult factory for pressure settings not shown.



16-501 (RVW16) SERIES

GENERAL PURPOSE LIQUID RELIEF

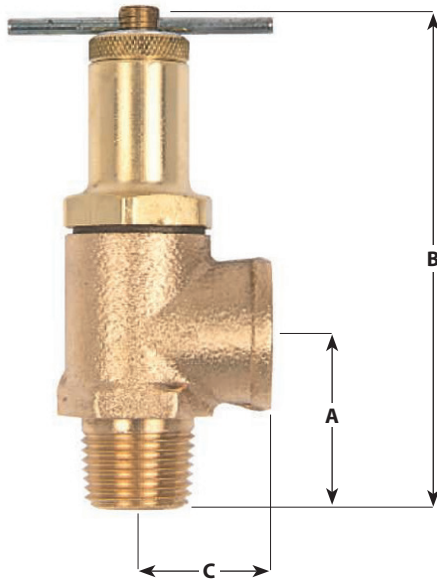

Adjustable relief valves protect equipment by providing low volume liquid relief or bypass control. Excess volume may be discharged back to the low pressure source. Ideal for agricultural sprayers and simple commercial or industrial pressurized systems.

FEATURES

- Adjustable Relief Settings, in Two Ranges to 600 psi
- Cast Bronze Body, Stainless Steel Springs
- Choice of Nitrile (Buna) or PTFE Soft Seats
- Knurled Locknut Locks Pressure Adjustment
- Viton Stem Seal, Polypropylene Body Gasket
- Maximum Recommended Service Temperature: 200°F

AVAILABLE CONFIGURATIONS

Model Number	Inlet Size (in./mm.)	Relief Range	Seat Material	Dimensions (in./mm.)			Wt./100 (lbs./kg.)
				A	B	C	
16-501-01	1/2 M X 1/2 F	50 - 250	Nitrile	1.29	4.12	1.00	62
16-501-02		250 - 600					
16-501-25	15 M x 15 F	50 - 250	PTFE	33	105	25	
16-501-60	250 - 600						

16-503 & 16-504 (RVW16) SERIES

GENERAL PURPOSE LIQUID RELIEF

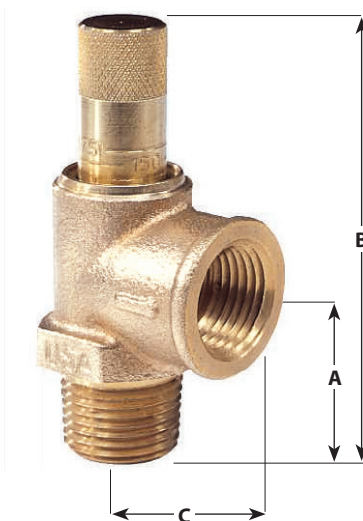

Calibrated pressure relief valve allows for in-line pressure adjustments without the need for a pressure gauge. Provides static overpressure protection for liquid filled systems such as well pumps, tanks, fire protection systems.

FEATURES

- Choice of 1/2" or 3/4" Inlet Connection
- Factory Preset at 100 psi
- Pressure Range 50 to 175 psi, Calibrated in 25 psi Increments
- Cast Bronze Body, Stainless Steel Spring
- Silicone Soft Seat, EPDM Cap Seal
- Maximum Recommended Service Temperature: 200°F
- Lead Free Option, Model 16LF is NSF/ANSI 372 Lead Free

AVAILABLE CONFIGURATIONS

Model Number	LF Model Number	Inlet Size (in./mm.)	Dimensions (in./mm.)			Wt./100 (lbs./kg.)	
			A	B	C		
16-503-01	16LF-503-01	1/2 M X 1/2 F	1.31	3.44	1.00	37	
		15 M x 15 F					
16-504-01	16LF-504-01	3/4 M X 1/2 F	33	87	25		17
		20 M x 15 F					



17-400 (RVW17) SERIES

PRESSURE ONLY HOT WATER RELIEF

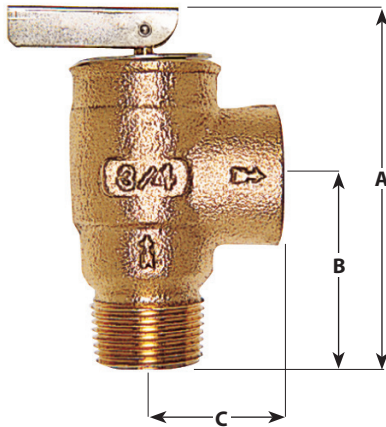

17-400 series pressure only relief valves are engineered to protect against excessive pressure buildup due to thermal expansion in hot water supply systems. Both models are CSA certified to ANSI Z21.22 "Relief Valves for Hot Water Supply Systems". In addition the 17-402 is design certified to ASME Section IV for hot water relief.

- Connection Sizes 1/2" (Model 17-401) and 3/4" (Model 17-402)
- CSA Verified to ANSI Z21.22
- Pressure Settings 75 thru 150 psi @ 250°F max.
- ASME Section IV Hot Water, Model 17-402 Only

APPLICATIONS

- **Model 17-401:** Overpressure Protection of Domestic Tankless Water Heaters. Also Ideal for Protecting Plumbing and Well Systems, Small Liquid Filled Vessels and Similar Equipment from Thermal Expansion or Pressure Surges
- **Model 17-402:** In Addition to the Above, also Suitable for ASME Section IV Hot Water Heating and Supply Boilers and Storage Tanks

FEATURES

- Cast Bronze Body, Stainless Steel Springs
- Soft Seat for Durability, Extended Service Life
- Conforms to HUD / FHA Requirements
- CSA Certified to ANSI Z21.22
- CSA B-51, CRN 0G8547.5C

AVAILABLE CONFIGURATIONS

Model Number	Inlet Size (in./mm.)	CSA Capacity Rating	ASME Capacity Rating	Dimensions (in./mm.)			Wt./100 (lbs./kg.)
				A	B	C	
17-401	1/2 M X 1/2 F	15,000	-	3.26	1.73	1.16	57
	15 M X 15 F			83	44	29	26
17-402	3/4 M X 3/4 F	200,000	See table below	3.14	1.62	1.13	53
	20 M X 20 F			80	41	29	24

ORDERING CODE

Use model number and two-digit suffix number to indicate size and set pressure.

P/N SUFFIX KEY

Set Pressure psig	Suffix	Btu/hr. ASME Sec. IV 17-402
75	-01	505,000
100	-02	648,000
125	-03	791,000
150	-04	934,000
160	-05	-

EXAMPLE:

17-401-03 = 1/2" model 17 set @ 125 psig.

17-402-04 = 3/4" model 17 set @ 150 psig.

NOTE:

- Valves may be set for any pressure between 70 and 175 psi. Consult factory for pressure settings not shown.
- ASME Section IV certified model 17-402 only, pressure settings 75 to 150 psig.



18C-400 (TP) & 18C-402X (TPX) SERIES

WATER HEATER T&P RELIEF

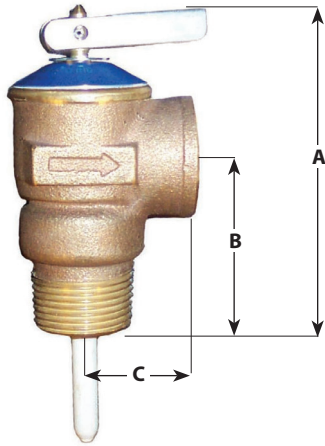

18C-400

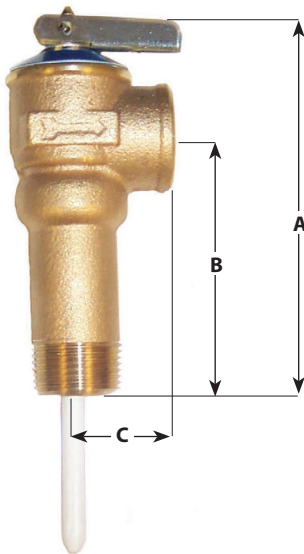

18C-402X
EXTENDED SHANK

Special statement regarding T&P Valves and compliance to the Lead Free requirements of the U.S. Safe Drinking Water Act.

Effective January 4th 2014 the SDWA requires that pipes, fittings or fixtures used to convey or dispense potable water must be lead free. Further clarification has been provided by the EPA in a document titled "Summary of the Reduction of Lead In Drinking Water Act and frequently Asked Questions". The latest document can be viewed on our website: www.apollovalves.com/lead_free; click on the NEW EPA FAQ link.

FAQ #6 states that water heaters are covered by the Act and must comply. However most water heater OEM's are certifying their heaters as complete assemblies using non-Lead Free T&P valves due to their relatively small wetted surface area.

FAQ #23 acknowledges this and states that replacement parts (including T&P valves) need not be lead free as long as the entire water heater with all installed components overall device would meet the Lead Free requirements of the Act.

Automatic temperature and pressure relief valves feature unique non-metallic coating which protects the element against galvanic and electromechanical corrosion by isolating it from the heated water. This coating is electrostatically applied for uniform coverage, then thermobonded, resulting in optimum adhesion for extended service life.

- CSA Design Certified at all Settings to ANSI Z21.22
- ASME Section IV rRted at 125 and 150 psig Settings for 3/4 NPT Only

APPLICATIONS

- Temperature and Pressure Protection for Hot Water Heaters and Storage Tanks

FEATURES

- Meets HUD/FHA Requirements
- Cast Bronze Body, Stainless Steel Spring
- Rated @ 210°F Maximum
- Registered in all Canadian Provinces and Territories
- ASME Capacity cCertified to 500,000 BTUhr.

OPTIONS

- Model 18C-402X Features a Body Inlet Extended 2" for Insulated Vessels

AVAILABLE CONFIGURATIONS

Model Number	Size (in./mm.)	Element Length (in./mm.)	CSA Capacity Rating Btu/HR	Dimensions (in./mm.)			Wt./100 (lbs./kg.)
				A	B	C	
18C-401	1/2 M x 1/2 F	1.44, 3 & 8"	15,000	3.25	1.75	1.13	64
	15 M x 15 F	37, 76 & 200		83	44	29	29
18C-402	3/4 M x 3/4 F	1.44	95,000	3.25	1.75	1.13	64
	20 M x 20 F	37		83	44	29	29
18C-402	3/4 M x 3/4 F	3 & 8"	105,000	3.25	1.75	1.13	64
	20 M x 20 F	76 & 200		83	44	29	29
18C-402X	3/4 M x 3/4 F	3"	105,000	4.51	2.97	1.13	75
	20 M x 20 F	76		115	75	29	34

ORDERING CODE

Use model number and two-digit suffix number to indicate size and set pressure.

P/N SUFFIX KEY - MODEL 18C-401

Set Pressure psig	Coated Element Length (in.)	
	1.44	3
125	-27	-29
150	-28	-30

EXAMPLE:

18C-402X-38 = 3/4" model 18C-402X set @ 150 psig with 3" element.
18C-402-30 = 3/4" model 18C-402 set @ 150 psig with 3" element.

P/N SUFFIX KEY - MODEL 18C-402X

Set Pressure psig	Coated Element Length (in.)
125	-39
150	-38

P/N SUFFIX KEY - MODEL 18C-402

Set Pressure psig	Coated Element Length (in.)		
	1.44	3	8
125	-27	-29	-36
150	-28	-30	-37
175		-24	



18C (TPC) SERIES

BRONZE HIGH CAPACITY COMMERCIAL T&P

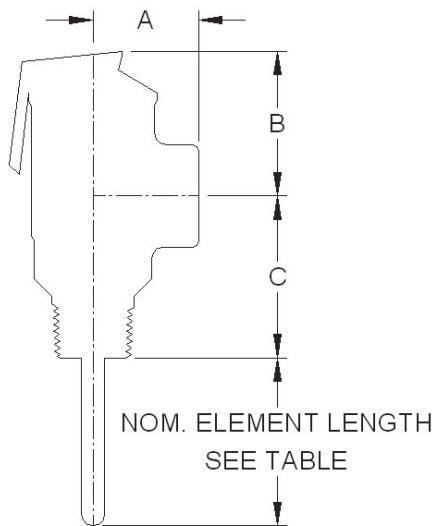

The Apollo[®] 18C-500 Series bronze automatic temperature and pressure relief valves are used for high capacity protection of commercial hot water heaters and storage tanks.

FEATURES

- ASME Section IV Certified Capacity
- 3/4" thru 2" NPT Connections
- CSA Listed and Certified to ANSI Z21.22
- 125 and 150 psig Set Pressures at 210°F max
- Coated Element Protects Against Corrosion
- SS Elements (1-1/2" and 2")
- ASME Section IV Heating Boilers
- Canadian Registration Number CSA- 0G1438.6C

CAPACITY

Part Number	Size (in.)	Element Length (in.)	Inlet Type	CSA Capacity Rating Btu/HR	*ASME Cap. Rating BTU/HR
18C5113125	3/4"	2.69"	M	185,000	1,619,000
18C5113150	3/4"	2.69"	M	185,000	1,912,000
18C5115125	3/4"	4.38"	M	205,000	1,619,000
18C5115150	3/4"	4.38"	M	205,000	1,912,000
18C5118125	3/4"	7.56"	M	205,000	1,619,000
18C5118150	3/4"	7.56"	M	205,000	1,912,000
18C5123125	3/4"	2.88"	F	185,000	1,619,000
18C5123150	3/4"	2.88"	F	185,000	1,912,000
18C5125125	3/4"	4.56"	F	205,000	1,619,000
18C5125150	3/4"	4.56"	F	205,000	1,912,000
18C5128125	3/4"	7.75"	F	205,000	1,619,000
18C5128150	3/4"	7.75"	F	205,000	1,912,000
18C5213125	1"	3.06"	M	500,000	1,825,000
18C5213150	1"	3.06"	M	500,000	2,155,000
18C5215125	1"	4.75"	M	500,000	1,825,000
18C5215150	1"	4.75"	M	500,000	2,155,000
18C5225125	1"	4.75"	F	750,000	3,070,000
18C5225150	1"	4.75"	F	750,000	3,625,000
18C5228125	1"	8.13"	F	750,000	3,070,000
18C5228150	1"	8.13"	F	750,000	3,625,000
18C5314125	1-1/4" x 1"	3.97"	M	750,000	3,070,000
18C5314150	1-1/4" x 1"	3.97"	M	750,000	3,625,000
18C5424125	1-1/2"	4.13"	F	1,200,000	5,125,000
18C5424150	1-1/2"	4.13"	F	1,200,000	6,050,000
18C5513125	2" x 1-1/2"	3.25"	M	1,200,000	5,125,000
18C5513150	2" x 1-1/2"	3.25"	M	1,200,000	6,050,000

* National Board certified capacity per ASME Section IV-Heating Boilers

AVAILABLE CONFIGURATIONS

Model Number	Inlet Size (in./mm.)	Dimensions (in./mm.)		
		A	B	C
18C511	3/4" M x 3/4" FNPT	1.50	3.47	2.53
	(20)	(40)	(88)	(64)
18C512	3/4" F x 3/4" FNPT	1.50	3.47	2.35
	(20)	(40)	(88)	(60)
18C521	1" M x 1" FNPT	1.56	3.47	2.38
	(25)	(40)	(88)	(60)
18C522	1" F x 1" FNPT	1.56	3.47	2.13
	(25)	(40)	(88)	(54)
18C531	1-1/4" M x 1" FNPT	1.75	4.34	1.91
	(32)	(44)	(110)	(49)
18C542	1-1/2" M x 1-1/2" FNPT	2.47	5.84	1.71
	(40)	(63)	(148)	(43)
18C551	2" M x 1-1/2" FNPT	2.47	5.84	2.59
	(50)	(63)	(148)	(66)

Special statement regarding T&P Valves and compliance to the Lead Free requirements of the U.S. Safe Drinking Water Act.

Effective January 4th 2014 the SDWA requires that pipes, fittings or fixtures used to convey or dispense potable water must be lead free. Further clarification has been provided by the EPA in a document titled "Summary of the Reduction of Lead In Drinking Water Act and frequently Asked Questions". The latest document can be viewed on our website: www.apollovalves.com/lead_free; click on the NEW EPA FAQ link.

FAQ #6 states that water heaters are covered by the Act and must comply. However most water heater OEM's are certifying their heaters as complete assemblies using non-Lead Free T&P valves due to their relatively small wetted surface area.

FAQ #23 acknowledges this and states that replacement parts (including T&P valves) need not be lead free as long as the entire water heater with all installed components overall device would meet the Lead Free requirements of the Act.



19 SERIES

BRONZE SAFETY VALVE

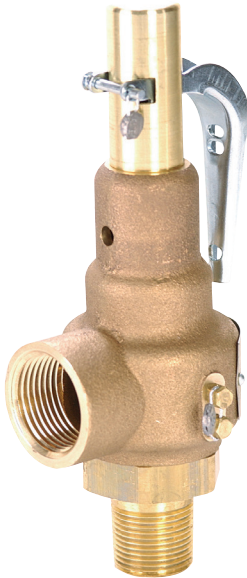

A dependable cast bronze high capacity safety valve ideal for use on all types of boilers, piping systems and unfired pressure vessels. This rugged design features top guided alignment for enhanced performance and reliability. Other features include optional metal seating, optional stainless steel wetted trim in all sizes, and a new, more descriptive model numbering system. Flow ratings are National Board certified in accordance with ASME sections I and VIII.

ASME SECTIONS I AND VIII

- Sizes 1/2" thru 2-1/2"
- Factory Set Pressures 5 to 300 psig
- Maximum Temperature: 406°F (Model 19S: 422°F)

APPLICATIONS

- Overpressure Protection of Steam Boilers, Sterilizers, Distillers, Cookers, and Pressure Reducing Stations.
- Pneumatic Conveying Equipment, Air Compressors, Receivers and Dryers. Steam, Air and Gas Accumulators, Pressure Vessels and Pressure Piping Systems.

FEATURES

- Wide Wrenching Hex for Easier, Faster Installations
- Stainless Steel Springs are Standard
- Teflon® PFA Seat Resists Corrosive Boiler Chemicals and Excessive Vibration
- High-Capacity Full Nozzle Design Available in Six Orifice Sizes
- Two Control Rings for Maximum Performance and Adjustability
- Short "Tuned" Blow Down Minimizes Product Loss
- Tapped Body Drain Allows Piping of Condensate Safely Away From Equipment
- Reduced Repair Costs: Soft Seat Easily Replaced
- Registered in all Canadian Provinces Under CSA B51 CRN 0G8547.5C

OPTIONS

- Choice of Teflon® or Metal-to-Metal Seating
- Steam Set Pressures to 300 psi @ 422°F (Model 19S, Stainless Steel Trim)
- 316 Stainless Steel Wetted Trim Available for all Sizes
- Anti-Vibration Dampened Lifting Lever
- Oxygen Cleaned
- European Pressure Equipment Directive Compliant Option (CE/PED)

SEATS

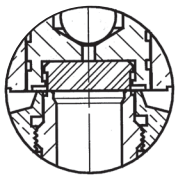

SOFT SEAT
MODEL 19K - BRASS
MODEL 19L - STAINLESS

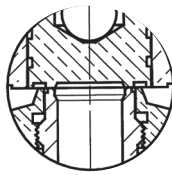

METAL-TO-METAL SEAT
MODEL 19M - BRASS
MODEL 19S - STAINLESS

TRIM STYLES

Series	19K	19M	19L	19S
Trim	Brass	Brass	SS	SS
Seat	Teflon®	Metal to Metal	Teflon®	Metal to Metal
Max. Set - Steam	250	250	250	300
Max. Set - Air/Gas	300	300	300	300
Max. Temperature	406°F	406°F	406°F	422°F

PART NUMBER MATRIX

19M	D	C	K	165	A
BASE MODEL NUMBER	ORIFICE LETTER	INLET SIZE (IN.) NPT	ASME CODE AND SERVICE	SET PRESSURE IN PSI	SPECIAL OPTIONS
19K = Brass Trim/Teflon Seat	D	C = 1/2	A = Sect. I Steam		A = Anti-vibration trim
19M = Brass Trim/Metal Seat	E	D = 3/4	K = Sect. VIII Air		CE = CE/PED Compliant
19L = Stainless Trim/Teflon Seat	F	E = 1	L = Sect. VIII Steam		Q = Performance (Calibration) test report
19S = Stainless Trim/Metal Seat	G	F = 1-1/4	N = Non-Code Air		X = Oxygen cleaning
	H	G = 1-1/2	P = Non-Code Steam		* Other suffixes - factory issued
	J	H = 2			
		J = 2-1/2			



19 SERIES

BRONZE SAFETY VALVE

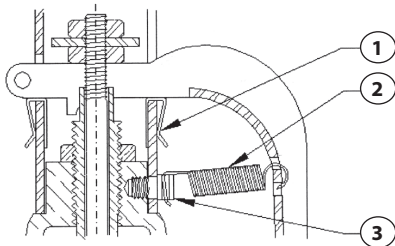
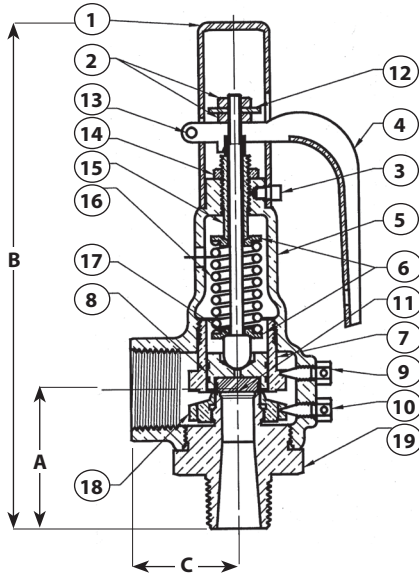

STANDARD MATERIAL LIST

		19K, 19M	19L, 19S
1	CAP	Brass	Brass
2	STEM NUT (2)	Steel, Plated	Steel, Plated
3	CAP LOCK SCREW	Brass	Brass
4	LIFT LEVER	Steel - Plated	Steel, Plated
5	BODY	Bronze	Bronze
6	SPRING WASHER (2)	Brass	Brass
7	GUIDE RING	Brass	Brass
8	DISC	Brass	Stainless Steel
9	GUIDE RING SCREW	Brass	Brass
10	NOZZLE RING SCREW	Brass	Brass
11	SEAT INSERT-19K & 19L	PFA Teflon®	PFA Teflon®
12	LIFT WASHER	Steel, Plated	Steel, Plated
13	LEVER PIN	Steel, Plated	Steel, Plated
14	ADJ. SCREW LOCK NUT	Steel, Plated	Steel, Plated
15	ADJUSTING SCREW	Brass	Brass
16	SPRING	Stainless Steel	Stainless Steel
17	STEM	Stainless Steel	Stainless Steel
18	NOZZLE RING	Brass	Brass
19	NOZZLE	Brass	Stainless Steel
-	NAMEPLATE	Stainless Steel	Stainless Steel
-	SEAL AND WIRE	Lead/SS*	Lead/SS*

* Alum/SS on CE models

19 SERIES WITH OPTION "A" ANTI-VIBRATION TRIM

1	FRICITION CLIP (4)	Steel, Plated
2	EXTENSION SPRING	Stainless Steel
3	CAP LOCK SCREW	Stainless Steel

Note: Preparation includes threadlocking of all internal threaded connections.

AVAILABLE CONFIGURATIONS

Old Model Number	New Model Number	Orifice Letter	Size (in./mm) Inlet x Outlet	Dimensions (in./mm.)			Wt./Ea. (lbs./kg.)
				A	B	C	
19-202	19*DC	D	1/2 X 3/4	2.21	6.52	1.37	1.6
			15 x 20	56	166	35	.73
19-301	19*DD	D	3/4 X 3/4	2.21	6.52	1.37	1.6
			20 x 20	56	166	35	.73
19-302	19*ED	E	3/4 X 1	2.50	7.16	1.75	2.0
			20 x 25	64	182	44	.91
19-401	19*EE	E	1 X 1	2.64	7.30	1.75	2.2
			25 x 25	67	185	44	1.0
19-402	19*FE	F	1 X 1-1/4	2.95	9.34	2.00	4.1
			25 x 32	75	237	51	1.9
19-501	19*FF	F	1-1/4 X 1-1/4	2.95	9.34	2.00	4.3
			32 x 32	75	237	51	2.0
19-502	19*GF	G	1-1/4 X 1-1/2	3.38	11.01	2.37	7.4
			32 x 40	86	280	60	3.4
19-601	19*GG	G	1-1/2 X 1-1/2	3.38	11.01	2.37	7.6
			40 x 40	86	280	60	3.4
19-602	19*HG	H	1-1/2 X 2	3.63	11.96	2.75	11.5
			40 x 50	92	304	70	5.2
19-701	19*HH	H	2 X 2	3.63	11.96	2.75	11.6
			50 x 50	92	304	70	5.3
	19*JG ¹	J	1-1/2F X 2-1/2	3.80	14.00	3.50	20.0
			40 x 65	97	356	89	9.1
19-702	19*JH	J	2 X 2-1/2	4.06	14.25	3.50	19.9
			50 x 65	103	362	89	9.0
19-801	19*JJ	J	2-1/2 X 2-1/2	4.50	14.68	3.50	20.8
			65 x 65	114	373	89	9.4

* Specify trim letter

¹: Available in bronze trim only, Model 19KJG & 19MJG.

Connections are 1-1/2" FNPT x 2-1/2" FNPT.

SAFETY RELIEF VALVES



"Apollo" COMMERCIAL PRODUCTS

19 SERIES

BRONZE SAFETY VALVE

ASME SECTION I - STEAM

ounds per hour (kilograms per hour) saturated steam @ 3% overpressure. National Board Certified. Ratings are 90% of actual.

US CUSTOMARY UNITS BTU/Hr.

METRIC UNITS Kcal/Hr.

Orifice Letter Area in. ²	D 0.129	E 0.230	F 0.359	G 0.589	H 0.919	J 1.509	Orifice Letter Area cm. ²	D 0.835	E 1.483	F 2.315	G 3.800	H 5.932	J 9.733
Set Pressure psig							Set Pressure barg						
15	174	310	484	794	1,240	2,035	0.34	-	-	-	-	-	-
20	201	359	561	920	1,435	2,356	0.69	-	-	-	-	-	-
25	229	408	637	1,045	1,631	2,677	1.1	81	145	226	371	579	951
30	256	457	713	1,170	1,826	2,998	1.5	96	171	266	437	682	1,120
35	284	506	790	1,296	2,022	3,319	2	114	203	317	519	811	1,331
40	311	555	866	1,421	2,217	3,641	2.5	132	235	367	602	940	1,542
45	339	604	942	1,546	2,413	3,962	3	150	267	417	684	1,068	1,753
50	366	653	1,019	1,672	2,608	4,283	3.5	168	299	467	767	1,197	1,964
55	394	702	1,095	1,797	2,804	4,604	4	186	331	517	849	1,326	2,175
60	421	751	1,172	1,922	2,999	4,925	4.5	204	364	568	932	1,454	2,386
65	448	800	1,248	2,048	3,195	5,246	5	222	397	619	1,016	1,586	2,602
70	476	849	1,326	2,175	3,394	5,573	5.5	241	430	671	1,101	1,719	2,820
75	505	900	1,405	2,304	3,596	5,904	6	259	463	723	1,186	1,851	3,037
80	533	950	1,483	2,433	3,797	6,234	6.5	278	496	774	1,271	1,984	3,255
85	561	1,001	1,562	2,563	3,998	6,565	7	296	529	826	1,356	2,116	3,472
90	590	1,051	1,641	2,692	4,200	6,896	7.5	315	562	878	1,440	2,249	3,690
95	618	1,101	1,719	2,821	4,401	7,226	8	334	595	929	1,525	2,381	3,907
100	646	1,152	1,798	2,950	4,602	7,557	8.5	352	628	981	1,610	2,514	4,125
105	674	1,202	1,877	3,079	4,804	7,888	9	371	662	1,033	1,695	2,646	4,342
110	703	1,253	1,955	3,208	5,005	8,218	9.5	389	695	1,085	1,780	2,779	4,559
115	731	1,303	2,034	3,337	5,207	8,549	10	408	728	1,136	1,865	2,911	4,777
120	759	1,353	2,113	3,466	5,408	8,880	10.5	426	761	1,188	1,950	3,044	4,994
125	787	1,404	2,191	3,595	5,609	9,210	11	445	794	1,240	2,035	3,176	5,212
130	816	1,454	2,270	3,724	5,811	9,541	11.5	464	827	1,292	2,120	3,309	5,429
135	844	1,505	2,349	3,853	6,012	9,872	12	482	860	1,343	2,204	3,441	5,647
140	872	1,555	2,427	3,982	6,213	10,202	12.5	501	893	1,395	2,289	3,574	5,864
145	900	1,605	2,506	4,111	6,415	10,533	13	519	927	1,447	2,374	3,706	6,082
150	929	1,656	2,585	4,240	6,616	10,864	13.5	538	960	1,498	2,459	3,839	6,299
160	985	1,757	2,742	4,499	7,019	11,525	14	556	993	1,550	2,544	3,971	6,517
170	1,042	1,857	2,899	4,757	7,422	12,186	15	594	1,059	1,654	2,714	4,236	6,951
180	1,098	1,958	3,057	5,015	7,824	12,848	16	631	1,125	1,757	2,884	4,501	7,386
190	1,155	2,059	3,214	5,273	8,227	13,509	17	668	1,192	1,861	3,053	4,767	7,821
200	1,211	2,160	3,371	5,531	8,630	14,170	18	705	1,258	1,964	3,223	5,032	8,256
210	1,268	2,261	3,529	5,789	9,033	14,832	19	742	1,324	2,067	3,393	5,297	8,691
220	1,324	2,361	3,686	6,047	9,436	15,493	20	779	1,390	2,171	3,563	5,562	9,126
230	1,381	2,462	3,843	6,305	9,838	16,154	20.7	805	1,437	2,243	3,682	5,747	9,430
240	1,438	2,563	4,001	6,564	10,241	16,816	Approx. 0.1 barg increments						
250	1,494	2,664	4,158	6,822	10,644	17,477		3.7	6.6	10.3	17.0	26.5	43.5
255	1,522	2,714	4,237	6,951	10,845	17,808	Note:						
260	1,551	2,765	4,315	7,080	11,047	18,138	<i>Specify model 19S with stainless steel wetted trim for steam settings beyond 250 psig / 17.2 barg.</i>						
265	1,579	2,815	4,394	7,209	11,248	18,469							
270	1,607	2,865	4,473	7,338	11,449	18,800							
275	1,635	2,916	4,551	7,467	11,651	19,130							
280	1,664	2,966	4,630	7,596	11,852	19,461							
285	1,692	3,017	4,709	7,725	12,053	19,792							
290	1,720	3,067	4,787	7,854	12,255	20,122							
295	1,748	3,117	4,866	7,983	12,456	20,453							
300	1,777	3,168	4,945	8,112	12,658	20,784							
Approx. 1 psi increments	5.7	10.0	15.6	25.8	40.2	66.0							



19 SERIES

BRONZE SAFETY VALVE

ASME SECTION VIII - STEAM

Pounds per hour (kilograms per hour) saturated steam at 10% overpressure. National Board Certified. Ratings are 90% of actual.

US CUSTOMARY UNITS Lbs./Hr.

METRIC UNITS Kg./Hr.

Orifice Letter Area in. ²	D 0.129	E 0.230	F 0.359	G 0.589	H 0.919	J 1.509	Orifice Letter Area cm. ²	D 0.835	E 1.483	F 2.315	G 3.800	H 5.932	J 9.733
Set Pressure psig							Set Pressure barg						
5*	122	218	340	558	871	1,429	0.34*	55	99	154	253	395	648
10*	167	298	466	765	1,193	1,958	0.69*	76	135	211	347	541	888
15	179	320	499	820	1,279	2,100	1.1	84	149	233	382	597	980
20	207	369	576	945	1,474	2,421	1.5	98	175	273	448	700	1,149
25	234	418	652	1,070	1,670	2,742	2	116	207	323	531	829	1,360
30	262	467	729	1,195	1,865	3,063	2.5	136	242	378	620	968	1,589
35	292	521	813	1,333	2,080	3,416	3	156	277	433	711	1,110	1,821
40	322	574	897	1,471	2,295	3,769	3.5	175	313	489	802	1,251	2,054
45	352	628	981	1,609	2,510	4,122	4	195	348	544	892	1,393	2,286
50	383	682	1,065	1,747	2,725	4,475	4.5	215	384	599	983	1,535	2,518
55	413	736	1,149	1,885	2,941	4,828	5	235	419	654	1,074	1,676	2,750
60	443	790	1,233	2,022	3,156	5,181	5.5	255	454	709	1,164	1,818	2,982
65	473	844	1,317	2,160	3,371	5,535	6	274	490	765	1,255	1,959	3,215
70	503	897	1,401	2,298	3,586	5,888	6.5	294	525	820	1,346	2,101	3,447
75	534	951	1,485	2,436	3,801	6,241	7	314	561	875	1,436	2,242	3,679
80	564	1,005	1,569	2,574	4,016	6,594	7.5	334	596	930	1,527	2,384	3,911
85	594	1,059	1,653	2,712	4,231	6,947	8	354	631	986	1,618	2,525	4,144
90	624	1,113	1,737	2,849	4,446	7,300	8.5	374	667	1,041	1,708	2,667	4,376
95	654	1,167	1,821	2,987	4,661	7,653	9	393	702	1,096	1,799	2,808	4,608
100	684	1,220	1,905	3,125	4,876	8,007	9.5	413	737	1,151	1,890	2,950	4,840
105	715	1,274	1,989	3,263	5,091	8,360	10	433	773	1,207	1,980	3,091	5,072
110	745	1,328	2,073	3,401	5,306	8,713	10.5	453	808	1,262	2,071	3,233	5,305
115	775	1,382	2,157	3,539	5,521	9,066	11	473	844	1,317	2,162	3,374	5,537
120	805	1,436	2,241	3,677	5,736	9,419	11.5	493	879	1,372	2,252	3,516	5,769
125	835	1,489	2,325	3,814	5,951	9,772	12	512	914	1,428	2,343	3,657	6,001
130	866	1,543	2,409	3,952	6,167	10,125	12.5	532	950	1,483	2,434	3,799	6,234
135	896	1,597	2,493	4,090	6,382	10,479	13	552	985	1,538	2,524	3,941	6,466
140	926	1,651	2,577	4,228	6,597	10,832	13.5	572	1,021	1,593	2,615	4,082	6,698
145	956	1,705	2,661	4,366	6,812	11,185	14	592	1,056	1,649	2,706	4,224	6,930
150	986	1,759	2,745	4,504	7,027	11,538	15	631	1,127	1,759	2,887	4,507	7,395
155	1,017	1,812	2,829	4,641	7,242	11,891	16	671	1,197	1,870	3,068	4,790	7,859
160	1,047	1,866	2,913	4,779	7,457	12,244	17	711	1,268	1,980	3,250	5,073	8,324
165	1,077	1,920	2,997	4,917	7,672	12,597	18	750	1,339	2,091	3,431	5,356	8,788
170	1,107	1,974	3,081	5,055	7,887	12,951	19	790	1,410	2,201	3,612	5,639	9,253
180	1,167	2,082	3,249	5,331	8,317	13,657	20	830	1,480	2,312	3,794	5,922	9,717
190	1,228	2,189	3,417	5,606	8,747	14,363	20.7	857	1,530	2,389	3,920	6,120	10,042
200	1,288	2,297	3,585	5,882	9,177	15,069	Approx. 0.1 barg increments						
210	1,349	2,405	3,753	6,158	9,608	15,776		4.0	7.1	11.5	18.1	28.3	46.4
220	1,409	2,512	3,921	6,433	10,038	16,482							
230	1,469	2,620	4,089	6,709	10,468	17,188							
240	1,530	2,727	4,257	6,985	10,898	17,894							
250	1,590	2,835	4,425	7,260	11,328	18,601							
255	1,620	2,889	4,509	7,398	11,543	18,954							
260	1,651	2,943	4,593	7,536	11,758	19,307							
265	1,681	2,997	4,677	7,674	11,973	19,660							
270	1,711	3,050	4,761	7,812	12,188	20,013							
275	1,741	3,104	4,845	7,950	12,403	20,366							
280	1,771	3,158	4,929	8,087	12,618	20,720							
285	1,801	3,212	5,013	8,225	12,834	21,073							
290	1,832	3,266	5,097	8,363	13,049	21,426							
295	1,862	3,320	5,181	8,501	13,264	21,779							
300	1,892	3,373	5,265	8,639	13,479	22,132							
Approx. 1 psi increments	6.0	10.8	16.8	27.6	43.0	70.6							

Note:

Specify model 19S with stainless steel wetted trim for steam settings beyond 250 psig / 17.2 barg.

*Settings below 15 psi (1.1 barg) are non-ASME code.



19 SERIES

BRONZE SAFETY VALVE

ASME SECTION VIII - AIR

Standard cubic feet per minute (normalized cubic meters per hour) of air at 10% overpressure. National Board Certified. Ratings are 90% of actual.

US CUSTOMARY UNITS SCFM

METRIC UNITS Nm³/Hr.

Orifice Letter Area in. ²	D 0.129	E 0.230	F 0.359	G 0.589	H 0.919	J 1.509	Orifice Letter Area cm. ²	D 0.835	E 1.483	F 2.315	G 3.800	H 5.932	J 9.733
Set Pressure psig							Set Pressure barg						
5*	39	69	108	178	277	455	0.34*	66	118	184	302	471	773
10*	54	97	151	248	387	635	0.69*	92	164	256	421	657	1,078
15	64	114	178	292	455	747	1.1	112	199	311	510	796	1,306
20	74	131	205	336	525	862	1.5	131	233	364	598	933	1,531
25	83	149	232	381	594	976	2	155	276	431	708	1,105	1,813
30	93	166	259	426	664	1,090	2.5	181	323	504	827	1,291	2,119
35	104	185	289	475	740	1,216	3	207	370	578	948	1,480	2,428
40	115	204	319	524	817	1,342	3.5	234	417	651	1,069	1,669	2,738
45	125	224	349	573	894	1,467	4	260	464	725	1,190	1,857	3,047
50	136	243	379	622	970	1,593	4.5	287	511	799	1,311	2,046	3,357
55	147	262	409	671	1,047	1,719	5	313	559	872	1,431	2,235	3,667
60	158	281	439	720	1,123	1,844	5.5	340	606	946	1,552	2,423	3,976
65	168	300	469	769	1,200	1,970	6	366	653	1,020	1,673	2,612	4,286
70	179	319	499	818	1,276	2,096	6.5	392	700	1,093	1,794	2,801	4,596
75	190	339	528	867	1,353	2,221	7	419	747	1,167	1,915	2,989	4,905
80	201	358	558	916	1,429	2,347	7.5	445	795	1,241	2,036	3,178	5,215
85	211	377	588	965	1,506	2,473	8	472	842	1,314	2,157	3,367	5,524
90	222	396	618	1,014	1,583	2,598	8.5	498	889	1,388	2,278	3,555	5,834
95	233	415	648	1,063	1,659	2,724	9	525	936	1,461	2,398	3,744	6,144
100	244	434	678	1,112	1,736	2,850	9.5	551	983	1,535	2,519	3,933	6,453
105	254	454	708	1,161	1,812	2,976	10	577	1,030	1,609	2,640	4,122	6,763
110	265	473	738	1,211	1,889	3,101	10.5	604	1,078	1,682	2,761	4,310	7,072
115	276	492	768	1,260	1,965	3,227	11	630	1,125	1,756	2,882	4,499	7,382
120	287	511	798	1,309	2,042	3,353	11.5	657	1,172	1,830	3,003	4,688	7,692
125	297	530	828	1,358	2,118	3,478	12	683	1,219	1,903	3,124	4,876	8,001
130	308	549	857	1,407	2,195	3,604	12.5	710	1,266	1,977	3,245	5,065	8,311
135	319	568	887	1,456	2,271	3,730	13	736	1,313	2,051	3,365	5,254	8,621
140	330	588	917	1,505	2,348	3,855	13.5	763	1,361	2,124	3,486	5,442	8,930
145	340	607	947	1,554	2,425	3,981	14	789	1,408	2,198	3,607	5,631	9,240
150	351	626	977	1,603	2,501	4,107	15	842	1,502	2,345	3,849	6,008	9,859
160	373	664	1,037	1,701	2,654	4,358	16	895	1,596	2,493	4,091	6,386	10,478
165	383	683	1,067	1,750	2,731	4,484	17	948	1,691	2,640	4,332	6,763	11,097
170	394	703	1,097	1,799	2,807	4,610	18	1,000	1,785	2,787	4,574	7,141	11,717
180	416	741	1,156	1,897	2,960	4,861	19	1,053	1,879	2,935	4,816	7,518	12,336
190	437	779	1,216	1,996	3,114	5,112	20	1,106	1,974	3,082	5,058	7,895	12,955
200	459	818	1,276	2,094	3,267	5,364	20.7	1,143	2,040	3,185	5,227	8,160	13,389
210	480	856	1,336	2,192	3,420	5,615	Approx. 0.1 barg increments	5.3	9.4	14.7	24.2	37.7	61.9
220	502	894	1,396	2,290	3,573	5,867							
230	523	932	1,456	2,388	3,726	6,118							
240	545	971	1,515	2,486	3,879	6,369							
250	566	1,009	1,575	2,584	4,032	6,621							
255	577	1,028	1,605	2,633	4,109	6,746							
260	587	1,047	1,635	2,682	4,185	6,872							
265	598	1,067	1,665	2,731	4,262	6,998							
270	609	1,086	1,695	2,781	4,338	7,124							
275	620	1,105	1,725	2,830	4,415	7,249							
280	630	1,124	1,755	2,879	4,491	7,375							
285	641	1,143	1,784	2,928	4,568	7,501							
290	652	1,162	1,814	2,977	4,645	7,626							
295	663	1,182	1,844	3,026	4,721	7,752							
300	673	1,201	1,874	3,075	4,798	7,878							
Approx. 1 psi increments	2.1	3.8	6.0	9.8	15.3	25.1							

Note:

To correct for temperature or specific gravities other than air (=1.0), multiply the SCFM from the capacity tables by factor Ksg

*Settings below 15 psi (1.1 barg) are non-ASME code.



29 SERIES

OEM STYLE BRONZE SAFETY VALVE



The Apollo® 29 Series is ideally suited for OEM applications where compact size, dependable performance and maximum economy are required. These rugged safety valves feature a top guided design and patented Teflon® “soft-seat” for dramatically reduced seat leakage. Flow ratings are National Board certified.

ASME SECTIONS I AND VIII

- Sizes 3/8" - 1-1/4" NPT
- Factory Set pressures 30 to 200 psig
- Maximum Temperature: 406°F

APPLICATIONS

- Small to Medium Sized Steam Power Boilers, Sterilizers and Distillers, Air Compressors and Receivers, Pressure Vessels and Pressure Piping Systems

FEATURES

- Stainless Steel Springs are Standard
- PFA Teflon® Seat Resists Corrosive Boiler Chemicals
- Rust-Proofed Steel Stem and Spring Washers
- Lower Control Ring Ensures Short, Consistent Blowdown
- Tapped Body Drain Allows Piping of Condensate Away from Equipment
- Reduced Repair Costs; Soft Seat Easily Replaced
- Registered in all Canadian Provinces Under CSA B51 CRN OG8547.5C

OPTIONS

- 316 Stainless Steel Wetted Trim (29-202 & 29-303 Sizes Only)
- Oxygen Cleaned
- European Pressure Equipment Directive Compliant Option (CE/PED)

STANDARD MATERIAL LIST

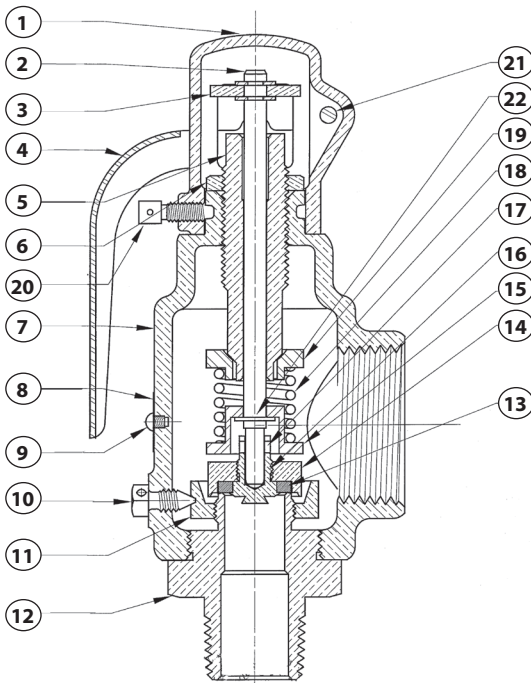

1	CAP	Bronze or Brass
2	STEM	Steel, Plated
3	LIFT WASHER	Steel, Plated
4	LIFT LEVER	Steel, Plated
5	ADJUSTING SCREW	Brass
6	LOCK NUT	Brass
7	BODY	Bronze
8	NAMEPLATE	Stainless Steel
9	DRIVE SCREWS	Stainless Steel
10	SET SCREW	Brass
11	BLOWDOWN RING	Brass
12	NOZZLE*	Brass/Stainless
13	SEAT INSERT	Teflon® PFA
14	DISC HOLDER	Brass
15	LOWER WASHER	Steel, Plated
16	SEAT RETAINER*	Brass/Stainless
17	STEM PIN	Stainless Steel
18	SPRING	Stainless Steel
19	UPPER WASHER	Steel, Plated
20	LOCK SCREW	Steel, Plated
21	LEVER PIN	Steel, Plated
22	RETAINING RING	Stainless Steel
-	SEAL & WIRE	Lead/Steel

*Optional stainless steel wetted trim for models 29-202XXL and 29-302XXL. Items 12 & 16 are type 316 stainless steel.



29 SERIES

OEM STYLE BRONZE SAFETY VALVE

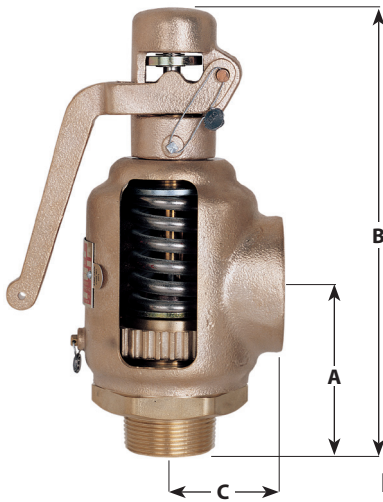

AVAILABLE CONFIGURATIONS

Model Number	Size (in./mm.)		Wt./Ea. (lbs./kg.)	Dimensions (in./mm.)		
	Inlet	Outlet		A	B	C
29-102	3/8	1	1.30	2.12	5.40	1.25
	10	25	.59	53	137	31
29-202	1/2	1	1.33	2.12	5.40	1.25
	15	25	.60	53	137	31
29-302	3/4	1	1.90	2.12	5.40	1.25
	20	25	.86	53	137	31
29-303	3/4	1-1/4	3.43	2.75	7.25	1.69
	20	32	1.55	69	184	42
29-402	1	1-1/4	3.43	2.75	7.25	1.69
	25	32	1.55	69	184	42
29-501	1-1/4	1-1/4	3.48	2.75	7.25	1.69
	32	32	1.58	69	184	42

PART NUMBER MATRIX

29	202	A	100	A
BASE MODEL NUMBER	INLET X OUTLET NTPPT	ASME CODE & SERVICE	SET PRESSURE (PSI)	SPECIAL OPTIONS
Bronze with Brass Trim and Teflon® Soft Seat	102 = 3/8 x 1 202 = 1/2 x 1 302 = 3/4 x 1 303 = 3/4 x 1-1/4 402 = 1 x 1-1/4 501 = 1-1/4 x 1-1/4	A = Sec I Steam K = Sec VIII Air L = Sec VIII Steam	Set Pressure (PSIG) (range 30-200 psig)	S = Stainless Steel Wetted Trim (models 29-202 & 29-303 only) C = CE/PED Q = Performance (Calibration) Test Reports *other suffixes - factory issued

*Not all configurations available together

EXAMPLE:

29 202 A100 = 1/2" x 1" 29 Series set @ 100 psig, ASME Section I "V" Steam
 29 202 L40 = 1/2" x 1" 29 Series set @ 40 psig, ASME Section I "UV" Steam
 29 303 K200 S = 3/4" x 1" 29 Series set @ 200 psig, ASME Section VIII "UV" Air, Stainless Steel Wetted Trim



29 SERIES

BRONZE SAFETY

ASME SECTION I - STEAM

Pounds per hour (kilograms per hour) saturated steam at 3% overpressure. National Board Certified. Ratings are 90% of actual.

US CUSTOMARY UNITS Lbs./Hr.

METRIC UNITS Kg./Hr.

Model No. Seat Dia. (in.)	29-102, 29-202, 29-302 0.500	29-303, 29-402, 29-501 0.737	Model No. Seat Dia. (mm.)	29-102, 29-202, 29-302 12.70	29-303, 29-402, 29-501 18.72
Set Pressure psig			Set Pressure barg		
30	164	330	2.1	77	155
35	182	367	2.5	86	174
40	201	405	3	98	197
45	220	442	3.5	110	221
50	238	479	4	122	245
55	257	517	4.5	134	269
60	275	554	5	146	293
65	294	591	5.5	158	318
70	312	628	6	170	342
75	331	664	6.5	182	367
80	349	702	7	195	391
85	368	739	7.5	207	416
90	386	777	8	219	440
95	405	814	8.5	231	465
100	423	851	9	243	489
105	442	888	9.5	255	514
110	460	925	10	268	538
115	479	963	10.5	280	563
120	497	1,000	11	292	587
125	516	1,036	11.5	304	612
130	534	1,074	12	316	636
135	553	1,112	12.5	329	661
140	571	1,149	13	341	685
145	590	1,186	13.5	353	710
150	608	1,223	13.8	360	724
155	627	1,261	Approx. 0.1 barg increments		
160	645	1,298		2.44	4.9
165	664	1,335			
170	683	1,372			
175	701	1,409			
180	720	1,447			
185	738	1,484			
190	757	1,521			
195	775	1,558			
200	794	1,596			
Approx. 1 psi increments	3.7	7.4			



29 SERIES

BRONZE SAFETY

ASME SECTION VIII - STEAM

Pounds per hour (kilograms per hour) saturated steam at 10% overpressure. National Board Certified. Ratings are 90% of actual.

US CUSTOMARY UNITS Lbs./Hr.

METRIC UNITS Kg./Hr.

Model No. Seat Dia. (in.)	29-102, 29-202, 29-302 0.500	29-303, 29-402, 29-501 0.737	Model No. Seat Dia. (mm.)	29-102, 29-202, 29-302 12.70	29-303, 29-402, 29-501 18.72
Set Pressure psig			Set Pressure barg		
30	164	330	2.1	79	158
35	182	367	2.5	89	179
40	201	405	3	102	205
45	220	442	3.5	115	231
50	238	479	4	128	257
55	257	517	4.5	141	284
60	275	554	5	154	310
65	294	591	5.5	167	336
70	312	628	6	180	362
75	331	664	6.5	193	388
80	349	702	7	206	414
85	368	739	7.5	219	441
90	386	777	8	232	467
95	405	814	8.5	245	493
100	423	851	9	258	519
105	442	888	9.5	271	545
110	460	925	10	284	571
115	479	963	10.5	297	598
120	497	1,000	11	310	624
125	516	1,036	11.5	323	650
130	534	1,074	12	336	676
135	553	1,112	12.5	349	702
140	571	1,149	13	362	728
145	590	1,186	13.5	375	755
150	608	1,223	13.8	383	770
155	627	1,261	Approx. 0.1 barg increments		
160	645	1,298		2.6	5.22
165	664	1,335			
170	683	1,372			
175	701	1,409			
180	720	1,447			
185	738	1,484			
190	757	1,521			
195	775	1,558			
200	794	1,596			
Approx. 1 psi increments	3.7	7.4			



29 SERIES

BRONZE SAFETY

ASME SECTION VIII - AIR

Standard cubic feet per minute (normalized cubic meters per hour) of air at 10% overpressure. National Board Certified. Ratings are 90% of actual.

US CUSTOMARY UNITS SCFM

METRIC UNITS Nm³./Hr.

Model No. Seat Dia. (in.)	29-102, 29-202, 29-302 0.500	29-303, 29-402, 29-501 0.737	Model No. Seat Dia. (mm.)	29-102, 29-202, 29-302 12.70	29-303, 29-402, 29-501 18.72
Set Pressure psig			Set Pressure barg		
30	61	123	2.1	105	210
35	68	137	2.5	118	238
40	75	151	3	136	273
45	82	165	3.5	153	308
50	89	180	4	170	342
55	96	193	4.5	188	377
60	103	208	5	205	412
65	110	222	5.5	222	447
70	117	236	6	240	482
75	124	250	6.5	257	516
80	131	264	7	274	551
85	138	278	7.5	291	586
90	145	292	8	309	621
95	152	307	8.5	326	655
100	159	321	9	343	690
105	166	335	9.5	361	725
110	173	349	10	378	760
115	180	363	10.5	395	795
120	187	378	11	413	829
125	194	392	11.5	430	864
130	201	406	12	447	899
135	208	420	12.5	464	934
140	215	434	13	482	969
145	222	448	13.5	499	1,003
150	229	463	13.8	509	1,024
155	236	477	Approx. 0.1 barg increments		
160	243	491			
165	250	505			
170	257	519			
175	265	533			
180	272	547			
185	279	562			
190	286	576			
195	293	590			
200	300	604			
Approx. 1 psi increments	1.4	2.8			
			3.46		6.96



119 SERIES

CAST IRON FLANGED SAFETY VALVE



These flanged, heavy duty and high capacity safety valves are ideal for use on all types of boilers, pressure vessels and pressure piping systems. These ruggedly built valves offer you a cost-saving alternative to conventional steel bodied valves – without compromising quality or performance. These valves feature a top guided design and two control rings to ensure seat tightness, repeatable performance and extended service life. Flow ratings are National Board certified.

ASME SECTIONS I AND VIII

- Set Pressures to 250 psig @ 450°F max
- Flanged Inlet Sizes 1 1/2" thru 6" ANSI 250 lb.
- Threaded Inlet Sizes 2" thru 3" FNPT

APPLICATIONS

- Overpressure Protection of Steam Boilers, Deaerators, Accumulators, Pressure Reducing Stations and Pressure Piping Systems
- Pneumatic Conveying Equipment, Air and Gas Compressors, Receivers and Dryers. Per ASME Code, Cast Iron Safety Relief Valves Must Not be Used for Lethal or Flammable Fluid Service

FEATURES

- Metal-to-Metal Seating, Lapped to Optical Flatness
- High-Capacity Semi-Nozzle Design Available in 8 Orifice Sizes
- Stainless Steel Wetted Trim is Standard
- Two Control Rings Assure Maximum Performance and Dependability
- Designed for New Installations and Replacement of Existing Valves (High Flow Rates and Face-to-Face Dimensions Enable Direct Replacement of Most Competitive Models)
- Designed for Ease of Service or Repair
- Ductile Iron Caps, Forks and Levers for Added Durability
- Registered in all Canadian Provinces Under CSA B51, CRN OG8547.5C

OPTIONS

- Drip Pan Elbows for Discharge Piping
- European Pressure Equipment Directive Compliant Option (CE/PED)

PART NUMBER MATRIX

119	K	H	C	A	MAA	0150	Q
SERIES NUMBER	ORIFICE LETTER	INLET (IN.)	CONNECTION	SERVICE	SPECIAL OPTIONS	SET PRESSURE	SUFFIX
119 = Stainless Steel Wetted Trim	The orifice letter from the Capacity Chart (pg. 39-41)	G = 1-1/2 H = 2 J = 2-1/2 K = 3 M = 4 P = 6	A = FNPT x FNPT C = 250# x FNPT D = 250# x 125#	A = Sec I Steam K = Sec VIII Air L = Sec VIII Steam N = Non Code Air P = Non Code Steam	Factory issued letters/numbers (MAA default) MCE = CE/PED	Set Pressure, PSIG (4 digits)	Q = Performance (Calibration) test reports

EXAMPLE:

119 KHC A MAA 0150 = 2" "K" 3" ASME Section I Steam, set @ 150 psig with flanged inlet
 119 QPD L MAA 0025 = 6" "K" 8" ASME Section VIII Steam, set @ 25 psig with flanged inlet



119 SERIES

CAST IRON FLANGED SAFETY VALVE

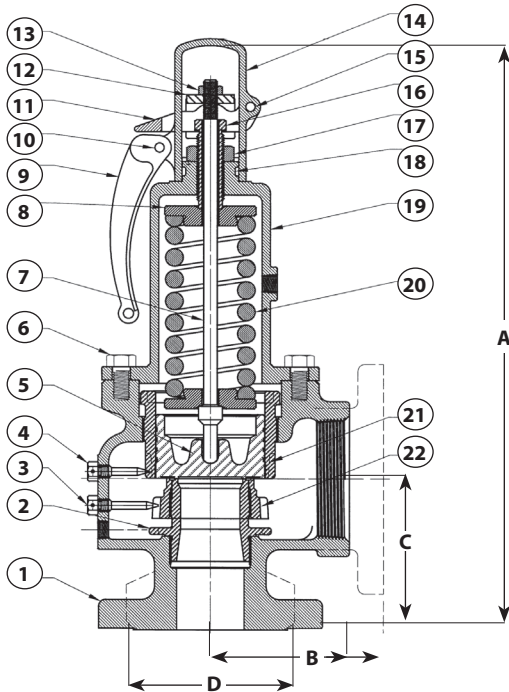

STANDARD MATERIAL LIST

1	BODY	Gray Iron
2	NOZZLE	Stainless Steel
3	NOZZLE RING SCREW	Brass
4	GUIDE RING SCREW	Brass
5	DISC	Stainless Steel
6	BONNET BOLT	Steel, Plated
7	STEM	Steel, Plated
8	SPRING WASHER	Steel, Plated
9	TEST LEVER	Ductile Iron
10	CLEVIS PIN	Steel, Plated
11	LIFTING FORK	Ductile Iron
12	STEM NUT	Steel, Plated
13	STEM NUT LOCK NUT	Steel, Plated
14	LIFTING CAP	Ductile Iron
15	CLEVIS PIN	Steel (Plated)
16	ADJUSTING SCREW	Brass
17	LOCK NUT	Steel, Plated
18	LIFT CAP LOCKSCREW	Steel, Plated
19	BONNET	Gray Iron
20	SPRING	Steel, Plated or SS
21	DISC GUIDE	Brass or Bronze
22	NOZZLE RING	Brass or Bronze
-	NAMEPLATE	Aluminum
-	SEAL AND WIRE	Lead/Steel
-	SEAL AND WIRE (CE)	Aluminum/SS

AVAILABLE CONFIGURATIONS

Model Number	Size (in./mm.) Inlet x Outlet	Orifice Size	Dimensions (in./mm.)			Hex Flat D (in./mm)	Weight (lbs./kg.)
			A	B	C		
119 JGC	1-1/2 250# X 2-1/2 FNPT DN40 x DN65	J	15	4	4.31		35
			381	101	109		15.8
119 KHC	2 250# X 3 FNPT DN50 x DN80	K	16	4	4.63		36
			406	101	109		16.3
119 KHA	2 FNPT X 3 FNPT DN50 x DN80	K	16	4	4.63	3.75	37
			406	101	109	95	16.7
119 KJC	2-1/2 250# X 3 FNPT DN65 x DN80	K	16	4	4.63		41
			406	101	109		18.6
119 KKC	3 250# X 3 FNPT DN80 x DN80	K	16	4	4.63		45
			406	101	109		20.5
119 LJC	2-1/2 250# X 4 FNPT DN65 x DN100	L	22	5.13	5.63		84
			558	130	143		38.1
119 LJA	2-1/2 FNPT X 4 FNPT DN65 x DN100	L	22	5.13	5.63	5.38	81
			558	130	143	136	36.7
119 LKC	3 250# X 4 FNPT DN80 x DN100	L	22	5.13	5.63		85
			558	130	143		38.5
119 LMC	4 250# X 4 FNPT DN100 x DN100	L	22	5.13	5.63		90
			558	130	143		40.9
119 MKA	3 FNPT X 4 FNPT DN80 x DN100	M	22	5.13	5.63	5.38	80
			558	130	143	136	36.2
119 MKC	3 250# X 4 FNPT DN80 x DN100	M	22	5.13	5.63		87
			558	130	143		39.4
119 MMC	4 250# X 4 FNPT DN100 x DN100	M	22	5.13	5.63		95
			558	130	143		43.2
119 NMD	4 250# X 6 125# DN100 x DN150	N	28	7.25	6.75		210
			711	184	171		95.2
119 PMD	4 250# X 6 125# DN100 x DN150	P	28	7.25	6.75		215
			711	184	171		97.5
119 QPD	6 250# X 8 125# DN150 x DN200	Q	42	10	9.25		530
			1066	254	234		240.4
119 RPD	6 250# X 8 125# DN150 x DN200	R	42	10	9.25		530
			1066	254	234		240.4



119 SERIES

CAST IRON FLANGED SAFETY VALVE

ASME SECTION I - STEAM

Pounds per hour (kilograms per hour) saturated steam at 3% overpressure. National Board Certified. Ratings are 90% of actual.

US CUSTOMARY UNITS Lbs./Hr.

METRIC UNITS Kg./Hr.

Orifice Letter Area in. ²	J 1.358	K 1.926	L 2.99	M 3.774	N 4.55	P 6.692	Q 11.593	R 16.786	Orifice Letter Area cm. ²	J 8.762	K 12.426	L 19.287	M 24.347	N 29.357	P 43.174	Q 74.795	R 108.294
Set Pressure psig									Set Pressure barg								
15	1,947	2,761	4,286	5,410	6,522	9,592	16,617	24,061	1.1	910	1,290	2,002	2,527	3,048	4,482	7,764	11,242
20	2,254	3,196	4,962	6,263	7,551	11,105	19,238	27,856	1.5	1,071	1,519	2,358	2,976	3,589	5,278	9,144	13,239
25	2,561	3,632	5,638	7,116	8,579	12,618	21,859	31,651	2	1,273	1,806	2,803	3,538	4,266	6,274	10,868	15,736
30	2,868	4,067	6,314	7,969	9,608	14,131	24,480	35,446	2.5	1,475	2,092	3,247	4,099	4,943	7,269	12,593	18,233
35	3,175	4,502	6,990	8,823	10,637	15,644	27,101	39,241	3	1,677	2,379	3,692	4,660	5,619	8,264	14,317	20,729
40	3,482	4,938	7,666	9,676	11,665	17,157	29,722	43,036	3.5	1,879	2,665	4,137	5,222	6,296	9,260	16,041	23,226
45	3,789	5,373	8,342	10,529	12,694	18,670	32,343	46,831	4	2,081	2,952	4,581	5,783	6,973	10,255	17,766	25,723
50	4,096	5,809	9,018	11,382	13,723	20,183	34,964	50,626	4.5	2,283	3,238	5,026	6,344	7,650	11,250	19,490	28,219
55	4,403	6,244	9,694	12,236	14,751	21,696	37,585	54,421	5	2,490	3,531	5,481	6,919	8,343	12,270	21,256	30,776
60	4,710	6,680	10,370	13,089	15,780	23,209	40,206	58,216	5.5	2,698	3,827	5,939	7,497	9,040	13,295	23,032	33,348
65	5,017	7,115	11,046	13,942	16,809	24,722	42,827	62,011	6	2,906	4,122	6,397	8,075	9,737	14,320	24,808	35,919
70	5,330	7,559	11,735	14,812	17,858	26,265	45,501	65,882	6.5	3,114	4,417	6,855	8,653	10,434	15,345	26,584	38,491
75	5,646	8,008	12,432	15,691	18,918	27,823	48,200	69,791	7	3,322	4,712	7,313	9,232	11,131	16,371	28,360	41,062
80	5,962	8,456	13,128	16,570	19,977	29,382	50,900	73,700	7.5	3,530	5,007	7,771	9,810	11,828	17,396	30,136	43,634
85	6,279	8,905	13,824	17,449	21,037	30,940	53,600	77,609	8	3,738	5,302	8,229	10,388	12,526	18,421	31,912	46,205
90	6,595	9,353	14,520	18,328	22,096	32,498	56,299	81,518	8.5	3,947	5,597	8,687	10,966	13,223	19,446	33,689	48,777
95	6,911	9,802	15,217	19,207	23,156	34,057	58,999	85,427	9	4,155	5,892	9,145	11,544	13,920	20,471	35,465	51,349
100	7,227	10,250	15,913	20,085	24,215	35,615	61,698	89,336	9.5	4,363	6,187	9,603	12,122	14,617	21,497	37,241	53,920
105	7,544	10,699	16,609	20,964	25,275	37,173	64,398	93,245	10	4,571	6,482	10,061	12,700	15,314	22,522	39,017	56,492
110	7,860	11,147	17,305	21,843	26,334	38,732	67,098	97,154	10.5	4,779	6,777	10,519	13,279	16,011	23,547	40,793	59,063
115	8,176	11,596	18,002	22,722	27,394	40,290	69,797	101,063	11	4,987	7,072	10,977	13,857	16,708	24,572	42,569	61,635
120	8,492	12,044	18,698	23,601	28,453	41,848	72,497	104,971	11.5	5,195	7,367	11,435	14,435	17,405	25,598	44,345	64,206
125	8,809	12,493	19,394	24,480	29,513	43,407	75,197	108,880	12	5,403	7,662	11,893	15,013	18,102	26,623	46,121	66,778
130	9,125	12,941	20,091	25,358	30,573	44,965	77,896	112,789	12.5	5,611	7,958	12,351	15,591	18,800	27,648	47,897	69,349
135	9,441	13,390	20,787	26,237	31,632	46,524	80,596	116,698	13	5,819	8,253	12,809	16,169	19,497	28,673	49,673	71,921
140	9,757	13,838	21,483	27,116	32,692	48,082	83,295	120,607	13.5	6,027	8,548	13,267	16,747	20,194	29,698	51,449	74,492
145	10,073	14,287	22,179	27,995	33,751	49,640	85,995	124,516	14	6,235	8,843	13,725	17,325	20,891	30,724	53,225	77,064
150	10,390	14,735	22,876	28,874	34,811	51,199	88,695	128,425	15	6,451	9,433	14,641	18,482	22,285	32,774	56,777	82,207
155	10,706	15,184	23,572	29,753	35,870	52,757	91,394	132,334	16	7,068	10,023	15,557	19,638	23,679	34,824	60,330	87,350
160	11,022	15,632	24,268	30,631	36,930	54,315	94,094	136,243	17	7,484	10,613	16,473	20,794	25,073	36,875	63,882	92,493
165	11,338	16,081	24,964	31,510	37,989	55,874	96,794	140,152	Approx 0.1 barg Increments	41.6	59.0	91.6	115.6	139.4	205.0	355.2	514.3
170	11,655	16,529	25,661	32,389	39,049	57,432	99,493	144,061									
175	11,971	16,978	26,357	33,268	40,108	58,990	102,193	147,969									
180	12,287	17,426	27,053	34,147	41,168	60,549	104,893	151,878									
185	12,603	17,875	27,750	35,026	42,228	62,107	107,592	155,787									
190	12,920	18,323	28,446	35,905	43,287	63,665	110,292	159,696									
195	13,236	18,772	29,142	36,783	44,347	65,224	112,991	163,605									
200	13,552	19,220	29,838	37,662	45,406	66,782	115,691	167,514									
205	13,868	19,669	30,535	38,541	46,466	68,340	118,391	171,423									
210	14,184	20,117	31,231	39,420	47,525	69,899	121,090	175,332									
215	14,501	20,566	31,927	40,299	48,585	71,457	123,790	179,241									
220	14,817	21,014	32,623	41,178	49,644	73,015	126,490	183,150									
225	15,133	21,463	33,320	42,056	50,704	74,574	129,189	187,059									
230	15,449	21,911	34,016	42,935	51,764	76,132	131,889	190,958									
235	15,766	22,360	34,712	43,814	52,823	77,691	134,589	194,876									
240	16,082	22,808	35,409	44,693	53,883	79,249	137,288	198,785									
245	16,398	23,257	36,105	45,572	54,942	80,807	139,988	202,694									
250	16,714	23,705	36,801	46,451	56,002	82,366	142,687	206,603									
Approx. 1 psi Increments																	
	63	90	139	176	212	312	540	782									





119 SERIES

CAST IRON FLANGED SAFETY

ASME SECTION VIII - STEAM

Pounds per hour (kilograms per hour) saturated steam at 10% overpressure. National Board Certified. Ratings are 90% of actual.

US CUSTOMARY UNITS Lbs./Hr.

METRIC UNITS Kg./Hr.

Orifice Letter Area in. ²	J 1.358	K 1.926	L 2.99	M 3.774	N 4.55	P 6.692	Q 11.593	R 16.786	Orifice Letter Area cm. ²	J 8.762	K 12.426	L 19.287	M 24.347	N 29.357	P 43.174	Q 74.795	R 108.294
Set Pressure psig									Set Pressure barg								
5*	1,312	1,860	2,888	3,645	4,395	6,464	11,198	16,213	.34*	590	836	1,298	1,639	1,976	2,906	5,034	7,289
10*	1,798	2,550	3,957	4,995	6,023	8,859	15,346	22,220	.69*	822	1,165	1,809	2,283	2,753	4,049	7,014	10,155
15	2,008	2,848	4,421	5,580	6,728	9,895	17,141	24,820	1.1	937	1,329	2,064	2,605	3,141	4,619	8,002	11,586
20	2,315	3,283	5,097	6,433	7,756	11,408	19,762	28,615	1.5	1,099	1,559	2,419	3,054	3,682	5,415	9,382	13,584
25	2,622	3,719	5,773	7,287	8,785	12,921	22,383	32,410	2	1,301	1,845	2,864	3,615	4,359	6,411	11,106	16,080
30	2,929	4,154	6,449	8,140	9,814	14,434	25,004	36,205	2.5	1,520	2,156	3,347	4,225	5,094	7,492	12,979	18,792
35	3,267	4,633	7,193	9,079	10,945	16,098	27,887	40,379	3	1,743	2,471	3,836	4,842	5,839	8,587	14,876	21,539
40	3,604	5,112	7,936	10,017	12,077	17,762	30,771	44,554	3.5	1,965	2,787	4,325	5,460	6,583	9,682	16,773	24,285
45	3,942	5,591	8,680	10,956	13,208	19,426	33,654	48,729	4	2,187	3,102	4,814	6,077	7,328	10,777	18,670	27,031
50	4,280	6,070	9,423	11,894	14,340	21,091	36,537	52,903	4.5	2,409	3,417	5,303	6,695	8,072	11,872	20,566	29,778
55	4,618	6,549	10,167	12,833	15,471	22,755	39,420	57,078	5	2,632	3,732	5,793	7,312	8,817	12,967	22,463	32,524
60	4,955	7,028	10,911	13,771	16,603	24,419	42,303	61,252	5.5	2,854	4,047	6,282	7,929	9,561	14,061	24,360	35,270
65	5,293	7,507	11,654	14,710	17,735	26,083	45,186	65,427	6	3,076	4,362	6,771	8,547	10,306	15,156	26,257	38,017
70	5,631	7,986	12,398	15,649	18,866	27,748	48,069	69,601	6.5	3,298	4,677	7,260	9,164	11,050	16,251	28,153	40,763
75	5,969	8,465	13,141	16,587	19,998	29,412	50,952	73,776	7	3,520	4,992	7,749	9,782	11,795	17,346	30,050	43,509
80	6,306	8,944	13,885	17,526	21,129	31,076	53,835	77,951	7.5	3,743	5,308	8,238	10,399	12,539	18,441	31,947	46,255
85	6,644	9,423	14,629	18,464	22,261	32,740	56,719	82,125	8	3,965	5,623	8,727	11,017	13,284	19,536	33,844	49,002
90	6,982	9,902	15,372	19,403	23,392	34,405	59,602	86,300	8.5	4,187	5,938	9,216	11,634	14,028	20,631	35,741	51,748
95	7,319	10,381	16,116	20,341	24,524	36,069	62,485	90,474	9	4,409	6,253	9,706	12,251	14,773	21,726	37,637	54,494
100	7,657	10,860	16,859	21,280	25,655	37,733	65,368	94,649	9.5	4,631	6,568	10,195	12,869	15,517	22,820	39,534	57,241
105	7,995	11,339	17,603	22,218	26,787	39,397	68,251	98,823	10	4,854	6,883	10,684	13,486	16,262	23,915	41,431	59,987
110	8,333	11,818	18,346	23,157	27,919	41,062	71,134	102,998	10.5	5,076	7,198	11,173	14,104	17,006	25,010	43,328	62,733
115	8,670	12,297	19,090	24,096	29,050	42,726	74,017	107,173	11	5,298	7,513	11,662	14,721	17,750	26,105	45,224	65,480
120	9,008	12,776	19,834	25,034	30,182	44,390	76,900	111,347	11.5	5,520	7,829	12,151	15,338	18,495	27,200	47,121	68,226
125	9,346	13,255	20,577	25,973	31,313	46,055	79,783	115,522	12	5,742	8,144	12,640	15,956	19,239	28,295	49,018	70,972
130	9,684	13,734	21,321	26,911	32,445	47,719	82,666	119,696	12.5	5,965	8,459	13,129	16,573	19,984	29,390	50,915	73,718
135	10,021	14,213	22,064	27,850	33,576	49,383	85,550	123,871	13	6,187	8,774	13,618	17,191	20,728	30,485	52,811	76,465
140	10,359	14,692	22,808	28,788	34,708	51,047	88,433	128,045	13.5	6,409	9,089	14,108	17,808	21,473	31,580	54,708	79,211
145	10,697	15,171	23,552	29,727	35,839	52,712	91,316	132,220	14	6,631	9,404	14,597	18,426	22,217	32,674	56,605	81,957
150	11,034	15,650	24,295	30,666	36,971	54,376	94,199	136,395	15	6,854	9,787	15,141	19,169	23,061	33,864	58,605	84,850
155	11,372	16,129	25,039	31,604	38,103	56,040	97,082	140,569	16	7,076	10,034	15,755	19,860	24,066	35,156	60,705	87,850
160	11,710	16,608	25,782	32,543	39,234	57,704	99,965	144,744	17	7,298	10,316	16,399	20,655	25,319	36,504	62,905	90,900
165	12,048	17,087	26,526	33,481	40,366	59,369	102,848	148,918	Approx. 0.1 barg Increment	44.4	63.0	97.8	123.5	148.9	219.0	379.4	549.3
170	12,385	17,566	27,270	34,420	41,497	61,033	105,731	153,093									
175	12,723	18,045	28,013	35,358	42,629	62,697	108,614	157,267									
180	13,061	18,524	28,757	36,297	43,760	64,361	111,497	161,442									
185	13,399	19,003	29,500	37,236	44,892	66,026	114,381	165,617									
190	13,736	19,482	30,244	38,174	46,023	67,690	117,264	169,791									
195	14,074	19,961	30,988	39,113	47,155	69,354	120,147	173,966									
200	14,412	20,440	31,731	40,051	48,287	71,018	123,030	178,140									
205	14,749	20,919	32,475	40,990	49,418	72,683	125,913	182,315									
210	15,087	21,398	33,218	41,928	50,550	74,347	128,796	186,489									
215	15,425	21,876	33,962	42,867	51,681	76,011	131,679	190,664									
220	15,763	22,355	34,706	43,806	52,813	77,675	134,562	194,839									
225	16,100	22,834	35,449	44,744	53,944	79,340	137,445	199,013									
230	16,438	23,313	36,193	45,683	55,076	81,004	140,329	203,188									
235	16,776	23,792	36,936	46,621	56,207	82,668	143,212	207,362									
240	17,113	24,271	37,680	47,560	57,339	84,332	146,095	211,537									
245	17,451	24,750	38,424	48,498	58,471	85,997	148,978	215,711									
250	17,789	25,229	39,167	49,437	59,602	87,661	151,861	219,886									
Approx. 1 psi Increment	68	96	149	188	226	333	577	835									

*Settings below 15 psi (1.1 barg) are non-ASME code.



119 SERIES

CAST IRON FLANGED SAFETY

ASME SECTION VIII - AIR

Standard cubic feet per minute (normalized cubic meters per hour) of air at 10% overpressure. National Board Certified. Ratings are 90% of actual.

US CUSTOMARY UNITS SCFM

METRIC UNITS Nm³/Hr.

Orifice Letter Area in. ²	J 1.358	K 1.926	L 2.99	M 3.774	N 4.55	P 6.692	Q 11.593	R 16.786	Orifice Letter Area cm. ²	J 8.762	K 12.426	L 19.287	M 24.347	N 29.357	P 43.174	Q 74.795	R 108.294
Set Pressure psig									Set Pressure barg								
5*	418	592	919	1,160	1,399	2,058	3,565	5,161	0.4*	722	1,024	1,589	2,006	2,418	3,557	6,161	8,921
10*	583	826	1,282	1,619	1,952	2,870	4,973	7,200	0.8*	1,005	1,425	2,212	2,793	3,367	4,952	8,579	12,422
15	715	1,014	1,574	1,986	2,395	3,522	6,101	8,834	1.1	1,182	1,677	2,603	3,286	3,961	5,826	10,093	14,615
20	824	1,169	1,814	2,290	2,761	4,060	7,034	10,185	1.5	1,386	1,996	3,052	3,852	4,644	6,831	11,833	17,134
25	933	1,324	2,055	2,594	3,127	4,599	7,967	11,536	2	1,641	2,327	3,613	4,560	5,498	8,086	14,008	20,283
30	1,043	1,479	2,295	2,897	3,493	5,138	8,900	12,887	2.5	1,918	2,720	4,222	5,329	6,425	9,449	16,370	23,703
35	1,163	1,649	2,560	3,231	3,896	5,730	9,926	14,373	3	2,198	3,117	4,839	6,108	7,364	10,830	18,762	27,166
40	1,283	1,820	2,825	3,566	4,299	6,322	10,953	15,859	3.5	2,478	3,514	5,456	6,887	8,303	12,211	21,154	30,630
45	1,403	1,990	3,089	3,900	4,701	6,915	11,979	17,345	4	2,758	3,912	6,073	7,665	9,241	13,592	23,546	34,094
50	1,523	2,161	3,354	4,234	5,104	7,507	13,005	18,830	4.5	3,038	4,309	6,690	8,444	10,180	14,973	25,938	37,557
55	1,644	2,331	3,619	4,568	5,507	8,099	14,031	20,316	5	3,319	4,707	7,307	9,223	11,119	16,354	28,331	41,021
60	1,764	2,502	3,884	4,902	5,910	8,692	15,057	21,802	5.5	3,599	5,104	7,924	10,002	12,058	17,735	30,723	44,485
65	1,884	2,672	4,148	5,236	6,312	9,284	16,084	23,288	6	3,879	5,502	8,541	10,780	12,997	19,115	33,115	47,948
70	2,004	2,843	4,413	5,570	6,715	9,877	17,110	24,774	6.5	4,159	5,899	9,158	11,559	13,936	20,496	35,507	51,412
75	2,124	3,013	4,678	5,904	7,118	10,469	18,136	26,260	7	4,439	6,296	9,775	12,338	14,875	21,877	37,899	54,876
80	2,245	3,184	4,942	6,238	7,521	11,061	19,162	27,746	7.5	4,720	6,694	10,392	13,116	15,813	23,258	40,291	58,339
85	2,365	3,354	5,207	6,572	7,924	11,654	20,188	29,232	8	5,000	7,091	11,009	13,895	16,752	24,639	42,683	61,803
90	2,485	3,524	5,472	6,906	8,326	12,246	21,215	30,718	8.5	5,280	7,489	11,626	14,674	17,691	26,020	45,076	65,267
95	2,605	3,695	5,736	7,240	8,729	12,838	22,241	32,204	9	5,560	7,886	12,243	15,453	18,630	27,400	47,468	68,730
100	2,726	3,865	6,001	7,574	9,132	13,431	23,267	33,689	9.5	5,841	8,283	12,860	16,231	19,569	28,781	49,860	72,194
105	2,846	4,036	6,266	7,908	9,535	14,023	24,293	35,175	10	6,121	8,681	13,477	17,010	20,508	30,162	52,252	75,658
110	2,966	4,206	6,530	8,243	9,937	14,616	25,320	36,661	10.5	6,401	9,078	14,093	17,789	21,447	31,543	54,644	79,121
115	3,086	4,377	6,795	8,577	10,340	15,208	26,346	38,147	11	6,681	9,476	14,710	18,568	22,385	32,924	57,036	82,585
120	3,206	4,547	7,060	8,911	10,743	15,800	27,372	39,633	11.5	6,961	9,873	15,327	19,346	23,234	34,305	59,428	86,049
125	3,327	4,718	7,324	9,245	11,146	16,393	28,398	41,119	12	7,242	10,271	15,944	20,125	24,263	35,686	61,820	89,512
130	3,447	4,888	7,589	9,579	11,548	16,985	29,424	42,605	12.5	7,522	10,668	16,561	20,904	25,202	37,066	64,213	91,976
135	3,567	5,059	7,854	9,913	11,951	17,577	30,451	44,091	13	7,802	11,065	17,178	21,683	26,141	38,447	66,605	96,440
140	3,687	5,229	8,118	10,247	12,354	18,170	31,477	45,577	13.5	8,082	11,463	17,795	22,461	27,080	39,828	68,997	99,903
145	3,807	5,400	8,383	10,581	12,757	18,762	32,503	47,063	14	8,362	11,860	18,412	23,240	28,019	41,209	71,389	103,367
150	3,928	5,570	8,648	10,915	13,160	19,355	33,529	48,549	15	8,642	12,255	19,029	24,019	29,000	42,590	73,770	105,831
155	4,048	5,741	8,912	11,249	13,562	19,947	34,556	50,034	16	8,923	12,655	19,646	24,819	29,981	43,971	75,151	108,295
160	4,168	5,911	9,177	11,583	13,965	20,539	35,582	51,520	17	9,204	13,055	20,263	25,619	30,962	45,352	76,532	110,759
165	4,288	6,082	9,442	11,917	14,368	21,132	36,608	53,006	Approx. 0.1 barg Increment	56.0	79.5	123.4	155.8	187.8	276.2	478.4	692.7
170	4,408	6,252	9,706	12,251	14,771	21,724	37,634	54,492									
175	4,529	6,423	9,971	12,586	15,173	22,317	38,660	55,978									
180	4,649	6,593	10,236	12,920	15,576	22,909	39,687	57,464									
185	4,769	6,764	10,500	13,254	15,979	23,501	40,713	58,950									
190	4,889	6,934	10,765	13,588	16,382	24,094	41,739	60,436									
195	5,010	7,105	11,030	13,922	16,784	24,686	42,765	61,922									
200	5,130	7,275	11,294	14,256	17,187	25,278	43,791	63,408									
205	5,250	7,446	11,559	14,590	17,590	25,871	44,818	64,893									
210	5,370	7,616	11,824	14,924	17,993	26,463	45,844	66,379									
215	5,490	7,787	12,088	15,258	18,396	27,056	46,870	67,865									
220	5,611	7,957	12,353	15,592	18,798	27,648	47,896	69,351									
225	5,731	8,128	12,618	15,926	19,201	28,240	48,923	70,837									
230	5,851	8,298	12,883	16,260	19,604	28,833	49,949	72,323									
235	5,971	8,469	13,147	16,594	20,007	29,425	50,975	73,809									
240	6,091	8,639	13,412	16,929	20,409	30,017	52,001	75,295									
245	6,212	8,810	13,677	17,263	20,812	30,610	53,027	76,781									
250	6,332	8,980	13,941	17,597	21,215	31,202	54,054	78,267									
Approx. 1 psi Increment	24	34	53	67	81	118	205	297									

*Settings below 15 psi (1.1 barg) are non-ASME code.



DRIP PAN ELBOWS (DPE)



The use of an Apollo International™ drip pan elbow is highly recommended for steam safety valve installations. The drip pan elbow connects to the valve outlet to safely direct steam discharge away from the valve and into the discharge piping. Condensate is directed to drain. Drip pans offer ideal flow characteristics, and serve to isolate the valve from piping stresses that can adversely effect safety valve performance and longevity.

- Sizes 3/4" thru 8", Flanged and Threaded Models
- Material: Gray iron ASTM A126 Class B
- Finish: Black Phosphate or Black Paint Coating

FEATURES

- Ideal Flow Characteristics
- Directs Condensate to Drain
- Isolates Safety Valve from Piping Stresses Caused by:
 - Weight of Discharge Piping
 - Thermal Expansion
 - Reaction Forces During Valve Discharge

INSTALLATION

- Sizes 3/4" thru 4" feature FNPT Connections and Connect Directly to the Valve Outlet by Means of a Short Pipe Nipple or with an Appropriate Companion Flange and Nipple for Flanged Outlet Connections
- Sizes 6" and 8" Have Integral Cast ANSI I25# Flanges that Bolt Directly to the Valve Outlet

FEATURES

- Select the Drip Pan to Match the Nominal Outlet Size of the Safety Valve

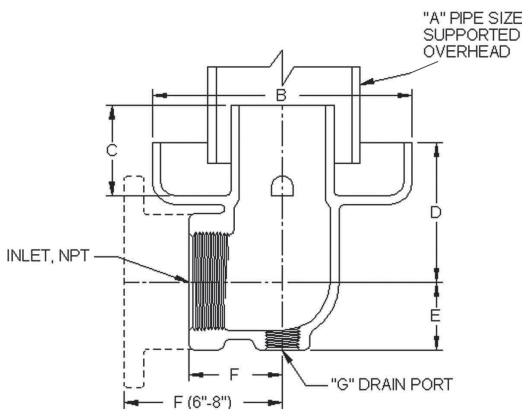

DIMENSIONS

Part Number	Size (In.) NPS/DN	Dimensions (in./mm.)							Wt./Ea. (lbs./kg.)
		A NPS/DN	B	C	D	E	F	G NPS/DN	
DPE 07	3/4	1-1/2	3.75	1.63	2.25	1	1.5	1/4	2
	20	40	95	41	57	25	40	8	.9
DPE 10	1	1-1/2	3.75	1.63	2.25	1	1.5	1/4	2
	25	40	95	41	57	25	40	8	.9
DPE 12	1-1/4	2	5.5	2.13	3.38	1.5	2.13	3/8	5
	32	50	127	54	86	40	54	10	2.1
DPE 15	1-1/2	2	5.5	2.13	3.38	1.5	2.13	3/8	5
	40	50	127	54	86	40	54	10	2.1
DPE 20	2	3	6.25	2.25	3.63	1.63	2.25	1/2	7
	50	80	159	57	92	41	57	15	3.2
DPE 25	2-1/2	4	7.38	3	4.38	1.88	2.75	3/4	11
	65	100	187	80	111	48	70	20	5.0
DPE 30	3	4	8	3.5	4.88	2.13	3.13	3/4	17
	80	100	200	89	124	54	80	20	7.7
DPE 40	4	6	9.63	4.5	5.75	2.63	3.75	3/4	30
	100	150	245	114	146	67	95	20	13.6
DPE 60	6	8	12.75	6.63	7.63	3	8	3/4	84
	150	200	324	168	194	80	200	20	38.1
DPE 80	8	10	16.5	7.5	8.63	4.13	10.75	1	151
	200	250	419	191	219	105	273	25	68.5



500 SERIES

MULTI-PURPOSE SAFETY RELIEF



Versatile safety relief valve available in bronze, carbon steel or all stainless steel construction, suitable for a wide range of steam, air, gas and liquid applications. High capacity full nozzle design is available with metal to metal, PCTFE or elastomer O-ring seating. Short tuned blowdown and backpressure tight body minimizes fugitive emissions and product losses in the event of valve operation.

ASME SECTION VIII

- Sizes 1/2" thru 2" NPT
 - Factory Set Pressure Range: 5-1200 psig @ 800°F max.
- (See Pressure/temperature Limit Chart Below for Specific Ratings for Each Model)

APPLICATIONS

- Pressure Vessels and Pressure Piping Systems
- Pumps, Tanks and Hydraulic Systems
- Thermal Relief of Liquid Filled Vessels
- Chemical, Process and Other Industrial Plants
- Power Plant Auxiliary Systems
- Cryogenic and Industrial Gases
- Air and Gas Compressors and Dryers
- Vacuum Relief

FEATURES

- Wide Range of Materials and Options
- One Trim Design is Suitable for Steam, Air / Gas and Liquid Service
- High Capacity Full Nozzle Design
- Stainless Steel Springs
- Integral Lift Stop
- Self-Aligning Pivoting Disc
- API 527 Seat Tightness, Standard for all Models
- Tuned Blowdown - Short and Adjustable, Reduces Product Losses
- Backpressure Tight Design Minimizes Fugitive Emissions
- CSA B51 CRN OG8547.5C

OPTIONS

- Screwed Cap Standard), Packed Lift Lever
- Test Gags
- Elastomer or PCTFE Soft Seat for Exceptional Seat Tightness
- High Temperature Alloy Springs for 550°F - 800°F Service
- Special Cleaning Available
- European Pressure Equipment Directive compliant option (CE/PED)

PART NUMBER MATRIX

52	3	J	H	B	K	M	AA	0425	Q
SERIES BODY/TRIM MATERIAL	CAP	ORIFICE LETTER	INLET SIZE	CONNECTION	SERVICE	SEAT	SPECIAL OPTIONS	SET PRESSURE	SUFFIX
51 = Bronze/Brass	1 = Screwed Cap	D	C = 1/2	B = MNPT x NPT	J = Sec VIII Liquid	M = Metal	Factory Issued	Set Pressure, PSIG (4 digits)	Q = Performance (Calibration) Test Reports
52 = Bronze/Stainless	2 = Screwed + Gag	E	D = 3/4	D = 3/4 Outlet (Model 510 & 520 D Orifice Only)	K = Sec VIII Air/Gas	B = BUNA-N	Letters/Numbers for Special Options or Features	Vacuum "HG"	
53 = Carbon/Stainless	3 = Packed Lever	F	E = 1		L = Sec VIII Steam	E = EPR	"AA" = Default Setting	Prefix + 2 digits	
54 = All Stainless	4 = Packed + Gag	G	F = 1-1/4		M = Non Code Liquid	K = PCTFE	"CE" = CE/PED		
		H	G = 1-1/2		N = Non Code Air	N = Neoprene	"HT" = High Temp Spring		
		J	H = 2		P = Non Code Steam	Z = Kalrez®	"OX" = Cleaned for Oxygen		
					Q = Vacuum	S = Silicone			
						V = Viton			

Notes:

1. The ASME Code Section VIII requires a lift lever for the following services: air, steam, or hot water over 140°F
2. Maximum back pressure is 50 psig.
3. High temperature stainless steel alloy spring is required above 550°F / 288°C. Specify option "HT" (Minimum pressure setting with HT option = 138 psig)
4. Contact factory for pricing and availability.



500 SERIES

MULTI-PURPOSE SAFETY RELIEF

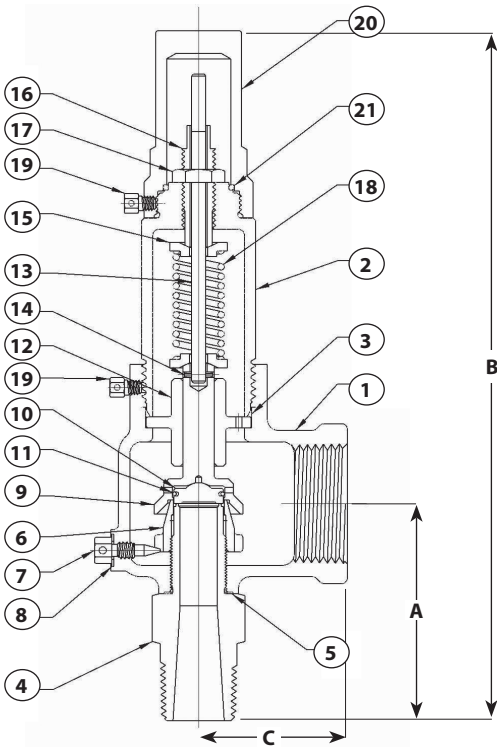

SCREWED CAP

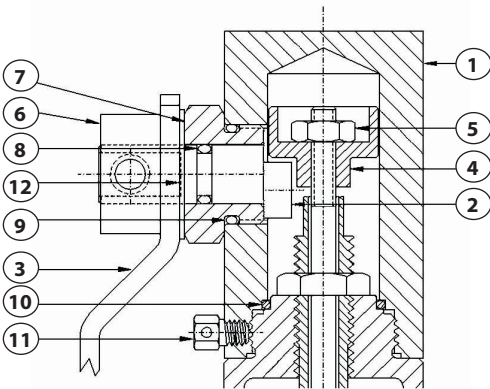

PACKED LEVER

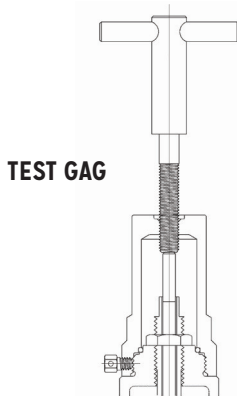

TEST GAG

STANDARD MATERIAL LIST

		510 Series	520 Series	530 Series	540 Series
1	BODY	Bronze, B-584-C844	Bronze, B-584-C844	Steel, SA-216 WCB	SS, SA-351-CF8M
2	BONNET	Brass*	Brass*	Steel**	SS Type 316***
3	BONNET SEAL	PTFE	PTFE	PTFE	PTFE
4	NOZZLE	Brass B-16	SS Type 316	SS Type 316	SS Type 316
5	NOZZLE SEAL	PTFE	PTFE	PTFE	PTFE
6	NOZZLE RING	SS Type 316	SS Type 316	SS Type 316	SS Type 316
7	SET SCREW	Brass	Brass	SS Type 316	SS Type 316
8	SET SCREW SEAL	PTFE	PTFE	PTFE	PTFE
9	DISC HOLDER	Brass	SS Type 316	SS Type 316	SS Type 316
10	DISC	SS Type 316	SS Type 316	SS Type 316	SS Type 316
11	RETAINING RING	Stainless Steel	Stainless Steel	Stainless Steel	Stainless Steel
12	DISC GUIDE	Brass	Brass	SS Type 316	SS Type 316
13	STEM	Brass	Brass	SS Type 316	SS Type 316
14	SPRING PIN	Stainless Steel	Stainless Steel	Stainless Steel	Stainless Steel
15	SPRING WASHER	Brass	Brass	SS Type 316	SS Type 316
16	ADJUSTING BOLT	Brass	Brass	SS Type 316	SS Type 316
17	LOCK NUT	Brass	Brass	SS Type 316	SS Type 316
18	SPRING	Stainless Steel	Stainless Steel	Stainless Steel	Stainless Steel
	SPRING, HIGH TEMP.	Inconel	Inconel	Inconel	Inconel
19	LOCK SCREW	Stainless Steel	Stainless Steel	Stainless Steel	Stainless Steel
20	CAP, SCREWED	Brass	Brass	Steel	SS Type 316
21	SEAL, CAP	Viton	Viton	Viton	Viton
-	NAMEPLATE	Stainless Steel	Stainless Steel	Stainless Steel	Stainless Steel
-	DRIVE SCREW	Stainless Steel	Stainless Steel	Stainless Steel	Stainless Steel
-	SEAL & WIRE	Lead/SS	Lead/SS	Lead/SS	Lead/SS
-	SEAL & WIRE (CE)			Alum/SS	Alum/SS

Notes:

* Sizes G, H and J are Cast Bronze

** Sizes H and J are Cast Steel

*** Sizes H and J are Cast Stainless Steel Type 316

LIFT LEVER OPTION

		513/523 Series	533 Series	543 Series
1	CAP, PACKED LEVER	Brass	Steel	SS Type 316
2	CAM BUSHING	Stainless Steel	Stainless Steel	Stainless Steel
3	LEVER	Stainless Steel	Stainless Steel	Stainless Steel
4	LIFT WASHER	Stainless Steel	Stainless Steel	Stainless Steel
5	LOCKNUT	Stainless Steel	Stainless Steel	Stainless Steel
6	COLLAR	Stainless Steel	Stainless Steel	Stainless Steel
7	CAM BUSHING	Brass	Stainless Steel	Stainless Steel
8	CAM O-RING	Viton	Viton	Viton
9	BUSHING O-RING	Viton	Viton	Viton
10	SEAL, CAP	Viton	Viton	Viton
11	SET SCREW	Stainless Steel	Stainless Steel	Stainless Steel
12	WASHER	PTFE	PTFE	PTFE

SEATS

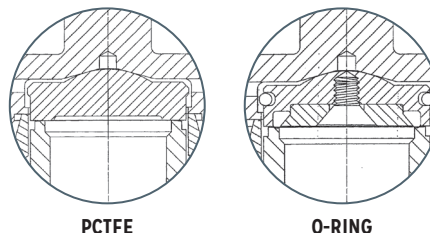

PCTFE

O-RING



500 SERIES

MULTI-PURPOSE SAFETY RELIEF

SOFT SEAT PRESSURE & TEMPERATURE LIMITS* - 500 SERIES

Seat Material	Set Pressure		Temperature		Service Recommendations**
	Min.	Max.	Min.	Max.	
Viton	15	900	-15°F	400°F	Air, Benzene, Butane, Carbon Dioxide, Carbon Disulphide, Carbon Tetrachloride, Dowtherm A, Ethyl Alcohol, Ethyl Chloride, Ethylene, Ethylene Glycol, Fuel Oil, Gasoline, Hydraulic Fluid, JP-4 and -5 Fuel, Kerosene, Lube Oil, Natural Gas, Naphtha, Nitrogen, Propane, Propyl Alcohol, Propylene, Propylene Glycol, Sulphur Dioxide, Toluene, Trichlorethylene, Turpentine, Vinyl Chloride, Water
EPDM	15	900	-70°F	250°F	Steam, Water, Hot Water, Acetone, Beer, Brake Fluid, Hydrogen Gas, Hydrogen Sulphide, Phosphate Ester Hydraulic Fluid, Sulphur Dioxide, Acids, Alkalis
Silicone	15	900	-60°F	450°F	Air, Helium, Nitrogen, Oxygen (gaseous)
Neoprene	15	900	-35°F	225°F	Air, Anhydrous Ammonia, Butane, Butyl Alcohol, Castor Oil, Denatured Alcohol, Ethanol, Ethyl Alcohol, Freon 12, 13, 14 & 22, Glycols, Natural Gas, Oxygen (gaseous), Silicate Esters
Nitrile / Buna-N	15	900	-30°F	250°F	Air, Anhydrous Ammonia, Butane, Carbon Dioxide, Diesel Oil, Freon 11 & 12, Fuel Oil, Gasoline, Helium, Hydraulic Fluid (petroleum based), Hydrogen Sulphide, Hydrogen Gas, Kerosene, Lube Oil, Natural Gas, Nitrogen, Oxygen (gaseous), Propane, Propylene, Sulphur Dioxide, Vinyl Chloride
PCTFE	15	500	-320°F	250°F	Cryogenic Service including Argon, Carbon Dioxide, Helium, Hydrogen, Nitrogen, Oxygen

Notes:

* Subject to valve body material pressure / temperature limitations. See chart below.

** Service recommendations are provided for guidance only. Material suitability and selection should be determined by the end user based on their prior experience with the service and materials involved.

PRESSURE AND TEMPERATURE RATINGS

Series Body Trim	510 Bronze Brass	520 Bronze Stainless	530 Carbon Steel Stainless	540 Stainless Steel Stainless
Max. Set-Steam	250 PSI	300 PSI	900 PSI (D/E) 600 PSI (F/G) 500 PSI (H/J)	900 PSI (D/E) 600 PSI (F/G) 500 PSI (H/J)
Max. Set-Air/Gas/Liquid	300 PSI	1200 PSI (D) ¹ 900 PSI (E) 600 PSI (F/G) 500 PSI (H/J)	1200 PSI (D) ¹ 900 PSI (E) 600 PSI (F/G) 500 PSI (H/J)	1200 PSI (D) ¹ 900 PSI (E) 600 PSI (F/G) 500 PSI (H/J)
Temp. Limits*	-320/406°F	-320/422°F	-20/800°F	-320/800°F

¹Max set pressure for liquids is 1000 psi.

Notes:

- Limits based upon materials of construction and use of metal to metal seating. Refer to 500 series soft seat chart for limitations based upon elastomer.
- Specify "HT" high temperature Inconel springs for service temperature beyond 422°F. (Minimum pressure setting with HT option = 138 psig)

* Models 510, 520 and 540 are suitable for cryogenic service to -320°F, with choice of either "M" metal or "K" PCTFE seat options.

AVAILABLE CONFIGURATIONS

Model Number	Orifice Letter	Size Inlet x Outlet	Dimensions (in./mm.)			Weight (Lb./kg.)
			A	B	C	
5xxDC	D	1/2 X 1	2.38	7.5	1.63	2
			60	191	41	0.9
5xxDCD*	D	1/2 X 3/4	2.38	7.5	1.63	2
			60	191	41	0.9
5xxDD	D	3/4 X 1	2.38	7.5	1.63	2
			60	191	41	0.9
5xxDDD*	D	3/4 X 3/4	2.38	7.5	1.63	2
			60	191	41	0.9
5xxED	E	3/4 X 1-1/4	2.63	9	2	3
			67	229	51	1.4
5xxEE	E	1 X 1-1/4	2.63	9	2	3
			67	229	51	1.4
5xxFE	F	1 X 1-1/2	2.83	10.25	2.38	5
			73	260	60	2.3
5xxFF	F	1-1/4 X 1-1/2	2.83	10.25	2.38	5
			73	260	60	2.3
5xxGF	G	1-1/4 X 2	3.25	13.25	2.63	9
			83	337	67	4.1
5xxGG	G	1-1/2 X 2	3.25	13.25	2.68	9.5
			83	337	67	4.31
5xxHG	H	1-1/2 X 2-1/2	3.5	15	2.75	15.5
			89	381	70	7.0
5xxHH	H	2 X 2-1/2	3.5	15	2.75	16
			89	381	70	7.3
5xxJH	J	2 X 3	4	17	3.25	24
			102	432	83	10.9

* 3/4" Outlet option available with 510 and 520 bronze bodied models only.



500 SERIES

MULTI-PURPOSE SAFETY RELIEF

ASME SECTION VIII - STEAM

Pounds per hour (kilograms per hour) saturated steam at 10% overpressure. National Board Certified. Ratings are 90% of actual.

US CUSTOMARY UNITS Lbs./Hr.

METRIC UNITS Kg./Hr.

Orifice Letter Area (in. ²)	D 0.1295	E 0.2282	F 0.3589	G 0.5890	H 0.9195	J 1.5044	Orifice Letter Area (cm. ²)	D 0.8352	E 1.4721	F 2.3155	G 3.8001	H 5.9321	J 9.7058
Set Pressure psig							Set Pressure barg						
5*	122	216	339	557	869	1,422	0.4*	60	105	165	271	423	692
10*	168	295	465	762	1,190	1,947	0.8*	82	145	228	374	583	955
15	188	331	520	853	1,332	2,180	1.1	88	154	243	398	622	1,018
20	216	381	600	984	1,536	2,513	2	122	214	337	553	863	1,412
25	245	432	679	1,114	1,740	2,846	3	163	287	451	741	1,156	1,892
30	274	482	759	1,245	1,943	3,180	4	204	360	566	930	1,451	2,374
35	305	538	846	1,388	2,168	3,546	5	246	433	681	1,118	1,746	2,857
40	337	593	934	1,532	2,392	3,913	6	287	506	797	1,307	2,041	3,339
45	368	649	1,021	1,676	2,616	4,280	7	329	580	912	1,496	2,336	3,821
50	400	705	1,108	1,819	2,840	4,646	8	370	653	1,027	1,685	2,630	4,304
55	431	760	1,196	1,963	3,064	5,013	9	412	726	1,142	1,874	2,925	4,786
60	463	816	1,283	2,106	3,288	5,380	10	453	799	1,257	2,063	3,220	5,269
65	494	872	1,371	2,250	3,512	5,746	12	536	945	1,487	2,441	3,810	6,233
70	526	927	1,458	2,393	3,736	6,113	14	619	1,092	1,717	2,818	4,400	7,198
75	558	983	1,546	2,537	3,960	6,479	16	702	1,238	1,947	3,196	4,989	8,163
80	589	1,038	1,633	2,680	4,184	6,846	18	786	1,384	2,178	3,574	5,579	9,128
85	621	1,094	1,721	2,824	4,408	7,213	20	869	1,531	2,408	3,952	6,169	10,093
90	652	1,150	1,808	2,968	4,632	7,579	22	952	1,677	2,638	4,329	6,758	11,058
95	684	1,205	1,896	3,111	4,857	7,946	24	1,035	1,823	2,868	4,707	7,348	12,022
100	715	1,261	1,983	3,255	5,081	8,313	26	1,118	1,970	3,098	5,085	7,938	12,987
125	873	1,539	2,421	3,972	6,201	10,146	28	1,201	2,116	3,329	5,463	8,527	13,952
150	1,031	1,817	2,858	4,690	7,322	11,979	30	1,284	2,262	3,559	5,840	9,117	14,917
175	1,189	2,095	3,295	5,408	8,442	13,812	32	1,367	2,409	3,789	6,218	9,707	15,882
200	1,346	2,373	3,733	6,126	9,562	15,645	34	1,450	2,555	4,019	6,596	10,297	16,846
225	1,504	2,651	4,170	6,843	10,683	17,478	36	1,533	2,701	4,249	6,974	-	-
250	1,662	2,929	4,607	7,561	11,803	19,312	38	1,616	2,848	4,479	7,351	-	-
275	1,820	3,207	5,045	8,279	12,924	21,145	40	1,699	2,994	4,710	7,729	-	-
300	1,977	3,485	5,482	8,997	14,044	22,978	42	1,782	3,140	-	-	-	-
325	2,135	3,763	5,919	9,714	15,165	24,811	44	1,865	3,287	-	-	-	-
350	2,293	4,041	6,357	10,432	16,285	26,644	46	1,948	3,433	-	-	-	-
375	2,451	4,319	6,794	11,150	17,405	28,477	48	2,031	3,579	-	-	-	-
400	2,608	4,597	7,231	11,867	18,526	30,311	50	2,114	3,726	-	-	-	-
425	2,766	4,875	7,669	12,585	19,646	32,144	52	2,197	3,872	-	-	-	-
450	2,924	5,153	8,106	13,303	20,767	33,977	54	2,280	4,019	-	-	-	-
475	3,082	5,431	8,543	14,021	21,887	35,810	58	2,446	4,311	-	-	-	-
500	3,239	5,709	8,981	14,738	23,008	37,643	62	2,612	4,604	-	-	-	-
525	3,397	5,987	9,418	15,456	-	-	65	2,736	-	-	-	-	-
550	3,555	6,266	9,855	16,174	-	-	69	2,902	-	-	-	-	-
575	3,713	6,544	10,293	16,892	-	-	72	3,026	-	-	-	-	-
600	3,870	6,822	10,730	17,609	-	-	76	3,192	-	-	-	-	-
625	4,028	7,100	-	-	-	-	79	3,316	-	-	-	-	-
650	4,186	7,378	-	-	-	-	82	3,441	-	-	-	-	-
675	4,344	7,656	-	-	-	-	Approx. 0.1 bar Increment						
700	4,501	7,934	-	-	-	-	4.15	7.32	11.51	18.89	29.48	48.24	
725	4,659	8,212	-	-	-	-	Maximum Set Pressure Limits for Steam Service						
750	4,817	8,490	-	-	-	-	510 Series - 250 psig/17.3 barg						
775	4,975	8,768	-	-	-	-	520 Series - 300 psig/20.7 barg						
800	5,132	9,046	-	-	-	-	530 Series - 900 psig/62.1 barg						
825	5,290	9,324	-	-	-	-	540 Series - 900 psig/62.1 barg						
850	5,448	9,602	-	-	-	-	<i>Note: For steam service beyond 300 psig or 550°F specify option "HT" high temperature stainless steel alloy spring.</i>						
875	5,606	9,880	-	-	-	-	<i>*Pressure settings below 15 psig/1.03 barg are non-ASME code.</i>						
900	5,763	10,158	-	-	-	-							
Approx. 1 psi Increment		6.3	11.1	17.5	28.7	44.8	73.3						

SAFETY RELIEF VALVES



"Apollo" COMMERCIAL PRODUCTS

500 SERIES

MULTI-PURPOSE SAFETY RELIEF

ASME SECTION VIII - AIR

Standard cubic feet per minute (normalized cubic meters per hour) of air at 10% overpressure. National Board Certified. Ratings are 90% of actual.

US CUSTOMARY UNITS SCFM

METRIC UNITS Kg./Hr.

Orifice Letter Area (in. ²)	D 0.1295	E 0.2282	F 0.3589	G 0.5890	H 0.9195	J 1.5044	Orifice Letter Area (cm ²)	D 0.8352	E 1.4721	F 2.3155	G 3.8001	H 5.9321	J 9.7058	
Set Pressure psig							Set Pressure barg							
5*	39	69	108	178	277	454	0.4*	67	119	187	307	479	784	
10*	54	96	151	248	387	633	0.8*	94	165	260	427	667	1,091	
15	67	118	185	304	474	776	1.1	110	195	306	503	784	1,283	
20	77	136	213	350	547	895	2	153	270	425	697	1,089	1,781	
25	87	154	242	397	619	1,013	3	205	362	569	934	1,458	2,386	
30	97	172	270	443	692	1,132	4	258	454	714	1,172	1,830	2,994	
35	109	191	301	494	772	1,262	5	310	546	859	1,411	2,202	3,603	
40	120	211	332	545	851	1,393	6	362	639	1,005	1,649	2,574	4,211	
45	131	231	363	596	931	1,523	7	415	731	1,150	1,887	2,946	4,819	
50	142	251	395	648	1,011	1,654	8	467	823	1,295	2,125	3,317	5,428	
55	154	271	426	699	1,091	1,784	9	519	916	1,440	2,363	3,689	6,036	
60	165	290	457	750	1,170	1,915	10	572	1,008	1,585	2,601	4,061	6,644	
65	176	310	488	801	1,250	2,045	12	676	1,192	1,875	3,078	4,805	7,861	
70	187	330	519	852	1,330	2,176	14	781	1,377	2,166	3,554	5,548	9,078	
75	198	350	550	903	1,410	2,306	16	886	1,561	2,456	4,031	6,292	10,295	
80	210	370	581	954	1,489	2,437	18	991	1,746	2,746	4,507	7,036	11,511	
85	221	389	612	1,005	1,569	2,567	20	1,095	1,931	3,037	4,983	7,779	12,728	
90	232	409	644	1,056	1,649	2,698	22	1,200	2,115	3,327	5,460	8,523	13,945	
95	243	429	675	1,107	1,729	2,828	24	1,305	2,300	3,617	5,936	9,267	15,162	
100	255	449	706	1,158	1,808	2,959	26	1,409	2,484	3,907	6,413	10,010	16,378	
125	311	548	862	1,414	2,207	3,611	28	1,514	2,669	4,198	6,889	10,754	17,595	
150	367	647	1,017	1,669	2,606	4,264	30	1,619	2,853	4,488	7,365	11,498	18,812	
175	423	746	1,173	1,925	3,005	4,916	32	1,724	3,038	4,778	7,842	12,241	20,029	
200	479	845	1,329	2,180	3,404	5,569	34	1,828	3,222	5,069	8,318	12,985	21,245	
225	535	944	1,484	2,436	3,802	6,221	36	1,933	3,407	5,359	8,795	-	-	
250	592	1,043	1,640	2,691	4,201	6,874	38	2,038	3,591	5,649	9,271	-	-	
275	648	1,142	1,796	2,947	4,600	7,526	40	2,142	3,776	5,939	9,747	-	-	
300	704	1,240	1,951	3,202	4,999	8,179	42	2,247	3,961	-	-	-	-	
325	760	1,339	2,107	3,458	5,398	8,831	44	2,352	4,145	-	-	-	-	
350	816	1,438	2,263	3,713	5,796	9,484	46	2,457	4,330	-	-	-	-	
375	872	1,537	2,418	3,969	6,195	10,136	48	2,561	4,514	-	-	-	-	
400	928	1,636	2,574	4,224	6,594	10,789	50	2,666	4,699	-	-	-	-	
425	985	1,735	2,730	4,480	6,993	11,441	52	2,771	4,883	-	-	-	-	
450	1,041	1,834	2,885	4,735	7,392	12,094	54	2,875	5,068	-	-	-	-	
475	1,097	1,933	3,041	4,991	7,791	12,746	58	3,085	5,437	-	-	-	-	
500	1,153	2,032	3,197	5,246	8,189	13,399	62	3,294	5,806	-	-	-	-	
525	1,209	2,131	3,352	5,501	-	-	65	3,450	-	-	-	-	-	
550	1,265	2,230	3,508	5,757	-	-	69	3,659	-	-	-	-	-	
575	1,321	2,329	3,664	6,012	-	-	72	3,815	-	-	-	-	-	
600	1,378	2,428	3,819	6,268	-	-	76	4,020	-	-	-	-	-	
625	1,434	2,527	-	-	-	-	79	4,177	-	-	-	-	-	
650	1,490	2,626	-	-	-	-	82	4,381	-	-	-	-	-	
675	1,546	2,725	-	-	-	-	Approx. 0.1 bar Increment							
700	1,602	2,824	-	-	-	-	5.24	9.23	14.51	23.82	37.18	60.84		
725	1,658	2,923	-	-	-	-								
750	1,715	3,022	-	-	-	-								
775	1,771	3,121	-	-	-	-								
800	1,827	3,220	-	-	-	-								
825	1,883	3,319	-	-	-	-								
850	1,939	3,418	-	-	-	-								
875	1,995	3,517	-	-	-	-								
900	2,051	3,616	-	-	-	-								
950	2,163	-	-	-	-	-								
1000	2,276	-	-	-	-	-								
1050	2,388	-	-	-	-	-								
1100	2,501	-	-	-	-	-								
1150	2,613	-	-	-	-	-								
1200	2,725	-	-	-	-	-								
Approx. 1 psi Increment							2.2	4.0	6.2	10.2	16.0	26.1		

Maximum Set Pressure Limits for Air/Gas Service

- 510 Series - 300 psig/20.7 barg
- 520 Series - 1200 psig/82.7 barg
- 530 Series - 1200 psig/82.7 barg
- 540 Series - 1200 psig/82.7 barg

*Pressure settings below 15 psig/1.03 barg are non-ASME code.





500 SERIES

MULTI-PURPOSE SAFETY RELIEF

ASME SECTION VIII - WATER

U.S. gallons per minute (cubic meters per hour) of water at 10% over pressure. National Board Certified. Ratings are 90% of actual.

US CUSTOMARY UNITS GPM

METRIC UNITS M3/Hr.

Orifice Letter Area (in. ²)	D 0.1295	E 0.2282	F 0.3589	G 0.5890	H 0.9195	J 1.5044	Orifice Letter Area (cm ²)	D 0.8352	E 1.4721	F 2.3155	G 3.8001	H 5.9321	J 9.7058
Set Pressure psig							Set Pressure barg						
5*	13	24	37	61	95	156	0.4*	2.0	3.6	5.6	9.2	14.4	23.6
10*	14	24	38	63	98	161	0.8*	2.9	5.1	8.0	13.1	20.4	33.3
15	14	25	40	65	102	167	1.1	3.3	5.9	9.3	15.2	23.8	38.9
20	16	29	45	74	115	189	2	4.4	7.7	12.1	19.8	30.9	50.6
25	18	32	50	82	127	208	3	5.3	9.4	14.8	24.2	37.8	61.8
30	19	34	54	89	138	226	4	6.1	10.8	17.0	28.0	43.6	71.4
35	21	37	58	96	149	244	5	6.9	12.1	19.0	31.3	48.8	79.8
40	22	40	62	102	160	261	6	7.5	13.3	20.9	34.2	53.4	87.4
45	24	42	66	108	169	277	7	8.1	14.3	22.5	37.0	57.7	94.5
50	25	44	70	114	178	292	8	8.7	15.3	24.1	39.5	61.7	101.0
55	26	46	73	120	187	306	9	9.2	16.2	25.6	41.9	65.5	107.1
60	28	48	76	125	195	320	10	9.7	17.1	26.9	44.2	69.0	112.9
65	29	50	79	130	203	333	12	10.6	18.8	29.5	48.4	75.6	123.7
70	30	52	82	135	211	345	14	11.5	20.3	31.9	52.3	81.6	133.6
75	31	54	85	140	218	357	16	12.3	21.7	34.1	55.9	87.3	142.8
80	32	56	88	145	226	369	18	13.0	23.0	36.1	59.3	92.6	151.5
85	33	58	91	149	233	381	20	13.7	24.2	38.1	62.5	97.6	159.7
90	34	59	93	153	239	392	22	14.4	25.4	39.9	65.6	102.3	167.5
95	35	61	96	158	246	402	24	15.1	26.5	41.7	68.5	106.9	174.9
100	36	63	98	162	252	413	26	15.7	27.6	43.4	71.3	111.3	182.0
125	40	70	110	181	282	462	28	16.3	28.7	45.1	74.0	115.5	188.9
150	44	77	121	198	309	506	30	16.8	29.7	46.7	76.6	119.5	195.5
175	47	83	130	214	334	546	32	17.4	30.6	48.2	79.1	123.4	202.0
200	50	89	139	229	357	584	34	17.9	31.6	49.7	81.5	127.2	208.2
225	53	94	148	242	378	619	36	18.4	32.5	51.1	83.9	-	-
250	56	99	156	256	399	653	38	18.9	33.4	52.5	86.2	-	-
275	59	104	163	268	418	685	40	19.4	34.2	53.9	88.4	-	-
300	62	108	171	280	437	715	42	19.9	35.1	-	-	-	-
325	64	113	178	291	455	744	44	20.4	35.9	-	-	-	-
350	66	117	184	302	472	772	46	20.8	36.7	-	-	-	-
375	69	121	191	313	489	799	48	21.3	37.5	-	-	-	-
400	71	125	197	323	505	826	50	21.7	38.3	-	-	-	-
425	73	129	203	333	520	851	52	22.2	39.0	-	-	-	-
450	75	133	209	343	535	876	54	22.6	39.8	-	-	-	-
475	77	136	215	352	550	900	58	23.4	41.2	-	-	-	-
500	79	140	220	361	564	923	62	24.2	42.6	-	-	-	-
525	81	143	226	370	-	-	65	24.8	-	-	-	-	-
550	83	147	231	379	-	-	69	25.6	-	-	-	-	-
575	85	150	236	388	-	-							
600	87	153	241	396	-	-							
625	89	157	-	-	-	-							
650	91	160	-	-	-	-							
675	92	163	-	-	-	-							
700	94	166	-	-	-	-							
725	96	169	-	-	-	-							
750	97	171	-	-	-	-							
775	99	174	-	-	-	-							
800	100	177	-	-	-	-							
825	102	180	-	-	-	-							
850	104	183	-	-	-	-							
875	105	185	-	-	-	-							
900	107	188	-	-	-	-							
950	109	-	-	-	-	-							
1000	112	-	-	-	-	-							

Maximum Set Pressure Limits for Liquid Service

- 510 Series - 300 psig/20.7 barg
- 520 Series - 1000 psig/68.9 barg
- 530 Series - 1000 psig/68.9 barg
- 540 Series - 1000 psig/68.9 barg

Note:

To determine water capacity at 25% overpressure, multiply the capacity at 10% by 1.066.

*Pressure settings below 15 psig/1.03 barg are non-ASME code.



EQUIVALENTS AND CONVERSION FACTORS

TO OBTAIN	MULTIPLY THIS	BY THIS
Atmospheres	Kilograms per sq. cm.	0.9678
Atmospheres	Pounds per sq. inch	0.068
Bar	Pounds per sq. inch	0.06895
Barrels	Cubic feet	0.1781
Bar	KiloPascals	0.01
Bar	Atmospheres	1.013
BTU/hr	Horsepower of boiler	33,479
BTU/hr	Kilowatts/hour	3,412
BTU/hr	MBH	1,000
BTU/hr	Pounds of steam/hour	1,000
BTU/hr	Watts/hour	3,412
Centimeters	Feet	30.48
Centimeters	Inches	2.54
Centimeters	Meters	100
Centipoise	SSU	0.2205 x SG
Centistoke	SSU	0.2162
Cubic centimeters	Cubic inches	16.39
Cubic centimeters	Gallons (U.S.)	3785
Cubic centimeters	Liters	1000
Cubic feet	Gallons (U.S.)	0.1337
Cubic feet	Liters	0.03531
Cubic feet per minute	Cubic meters per minute	35.31
Cubic feet per second	Gallons per minute	0.002228
Cubic inches	Gallons (U.S.)	231
Cubic inches	Gallons (Imperial)	277.4
Cubic meters per minute	Cubic feet per minute	0.02832
Cubic yards	Cubic centimeters	0.06102
Feet	Centimeters	0.03281
Feet	Inches	0.08333
Feet	Meters	3.281
Feet of water	Atmospheres	33.96
Feet of water (68°F)	Inches of mercury (0°C)	1.135
Feet of water (68°F)	Pounds per sq. inch	2.311
Gallons	Cubic feet	7.481
Gallons	Cubic inches	0.004329
Gallons	Cubic meters	264.2
Gallons	Liters	0.2642
Gallons (Imperial)	Gallons (U.S.)	0.8327
Gallons (U.S.)	Barrels	42
Gallons H2O @ 60°F (US)	Pounds	0.1199
Gallons per minute	Cubic feet per second	448.8
Gallons per minute	Cubic meters per hour	4.403
Gallons per minute	Liters per hour	0.004403
Gallons per minute liquid	Pounds per hour liquid	0.002/Sp.Gr.
Grams	Pounds	453.6
Inches	Centimeters	0.3937
Inches	Meters	39.97
Inches of mercury	Atmospheres	29.92
Inches of mercury	Kilograms per sq. cm	28.96
Inches of mercury (0°C)	Inches of water (68°F)	0.07343
Inches of mercury (0°C)	Feet of water (68°F)	0.8812
Inches of mercury (0°C)	Pounds per sq. inch	2.036
Inches of water	Atmospheres	407.5
Inches of water (68°F)	Pounds per sq. inch	27.73
Kilograms	Pounds	0.4536
Kilograms per hour	Pounds per hour	0.4536
Kilograms per hour	Gallons per minute (60°F)	227.0xSG
Kilograms per sq. cm	KiloPascals	0.0102
Kilograms per sq. cm	Inches of mercury (0°C)	0.03453
Kilograms per sq. cm	Bars	1.02
Kilograms per sq. cm.	Atmospheres	1.033
Kilograms per sq. cm.	Pounds per sq. inch	0.07031
KiloPascals	Pounds per sq. inch	6.895
KiloPascals	Atmospheres	101.3
KiloPascals	Bars	100
Liters	Gallons (U.S.)	3.785

TO OBTAIN	MULTIPLY THIS	BY THIS
Liters per minute	Gallons per minute	3.785
Liters per second	Gallons per minute	0.06309
M ³ /hr.	Gallons per minute	0.2271
Meters	Inches	0.0254
Meters	Centimeters	0.01
Meters	Feet	0.3048
Meters of water (68°F)	Pounds per sq. inch	0.7043
Metric tons	Pounds	0.0004536
Millimeters of mercury	Atmospheres	760
Millimeters of mercury (0°C)	Pounds per sq. inch	51.71
Molecular weight (of gas or vapors)	Specific gravity (of gas or vapors)	28.97
Nm ³ /day. (0°C, 1 Bara)	Standard cubic feet per min.	39.11
Nm ³ /hr. (0°C, 1 Bara)	Standard cubic feet per min.	1.63
Nm ³ /min. (0°C, 1 Bara)	Standard cubic feet per min.	0.02716
Ounces	Grams	0.03527
Ounces	Kilograms	35.27
Ounces	Pounds	16
Pounds	Gallons of water (60°F)	8.337
Pounds	Kilograms	2.205
Pounds	Water (cubic feet @ 60F)	62.37
Pounds per cubic foot	Kilograms per cubic meter	0.0624
Pounds per hour	Kilograms per minute	132.3
Pounds per hour liquid	Gallons of liquid per minute	500xSp. Gr.
Pounds per sq. in.	Inches of water (68°F)	0.03607
Pounds per sq. in.	Kilograms per sq. cm.	14.22
Pounds per sq. in.	KiloPascals	0.145
Pounds per square inch	Inches of mercury (0°C)	0.4912
Pounds per square inch	Atmospheres	14.7
Pounds per square inch	Bars	14.5
Pounds per square inch	Feet of water (68°F)	0.4328
PSI	MegaPascals	145.038
SCFM	Pounds per hour	6.324/M.W.
Short tons (2000 lbs.)	Kilograms	0.001102
Short tons (2000 lbs.)	Pounds	0.0005
Sm ³ /day.	Standard cubic feet per min.	40.78
Sm ³ /hr.	Standard cubic feet per min.	1.699
Sm ³ /min.	Standard cubic feet per min.	0.02832
Square centimeter	Square inch	6.4516
Square inch	Square centimeter	0.155
Square millimeter	Square inch	645.16
Standard cubic ft. per day	Standard cubic feet per min.	1440
Standard cubic ft. per hr	Standard cubic feet per min.	60
Yards	Centimeters	0.01094
Yards	Feet	0.3333
Yards	Inches	0.02778
Yards	Meters	1.094
TEMPERATURE:		
Centigrade	= 5/9 (Fahrenheit - 32)	
Kelvin	= Centigrade + 273	
Fahrenheit	= 9/5 (Centigrade) + 32	
Fahrenheit	= Rankine - 460	
Fahrenheit	= (9/5 Kelvin) - 460	



CORRECTION FACTORS

AIR AND GAS TEMPERATURE

To correct for temperatures other than 60°F at the valve inlet, multiply the SCFM from the capacity tables by factor K_t .

Temp °F	K_t
0	1.063
10	1.052
20	1.041
30	1.030
40	1.020
50	1.010
60	1.000
70	0.991
80	0.981
90	0.972
100	0.964
120	0.947
140	0.931
160	0.916
180	0.901
200	0.888
220	0.874
240	0.862
260	0.850
280	0.838
300	0.827
320	0.816
340	0.806
360	0.796
380	0.787
400	0.778
420	0.769
440	0.760
460	0.752
480	0.744
500	0.737
550	0.718
600	0.701
650	0.685
700	0.669
750	0.656

GAS AND LIQUID RELATIVE DENSITY

To correct for a specific gravity other than air or water (=1.0) multiply the SCFM or GPM from the capacity tables by factor K_{sg} .

Specific Gravity	K_{sg}
0.10	3.160
0.20	2.240
0.30	1.825
0.40	1.580
0.50	1.414
0.55	1.350
0.60	1.290
0.65	1.240
0.70	1.195
0.75	1.155
0.80	1.117
0.90	1.085
0.95	1.025
1.00	1.00
1.05	0.975
1.10	0.955
1.15	0.933
1.20	0.913
1.25	0.913
1.30	0.877
1.40	0.845
1.50	0.817
1.60	0.791
1.70	0.768
1.80	0.745
1.90	0.725
2.00	0.707
2.50	0.633
3.00	0.577
3.50	0.535
4.00	0.500
4.50	0.471