

Air Impact Wrench

285B Series



Product Parts Information



Save These Instructions

When tool life has expired, it is recommended to:

- disassemble the tool
- degrease the tool
- separate tool parts by material for correct recycling

Tool repair and maintenance should be conducted by an authorized service center.

Refer all communications to the nearest **Ingersoll Rand** office or distributor.

Manuals are available at ingersollrand.com

Table 1. Product Information Manuals

Publication	CCN
Product Safety Information Manual	04580916
Product Information Manual	45573011
Declaration of Conformity	47616446001

285B Series, Air Impact Wrench

Figure 1. Exploded View - 16578726

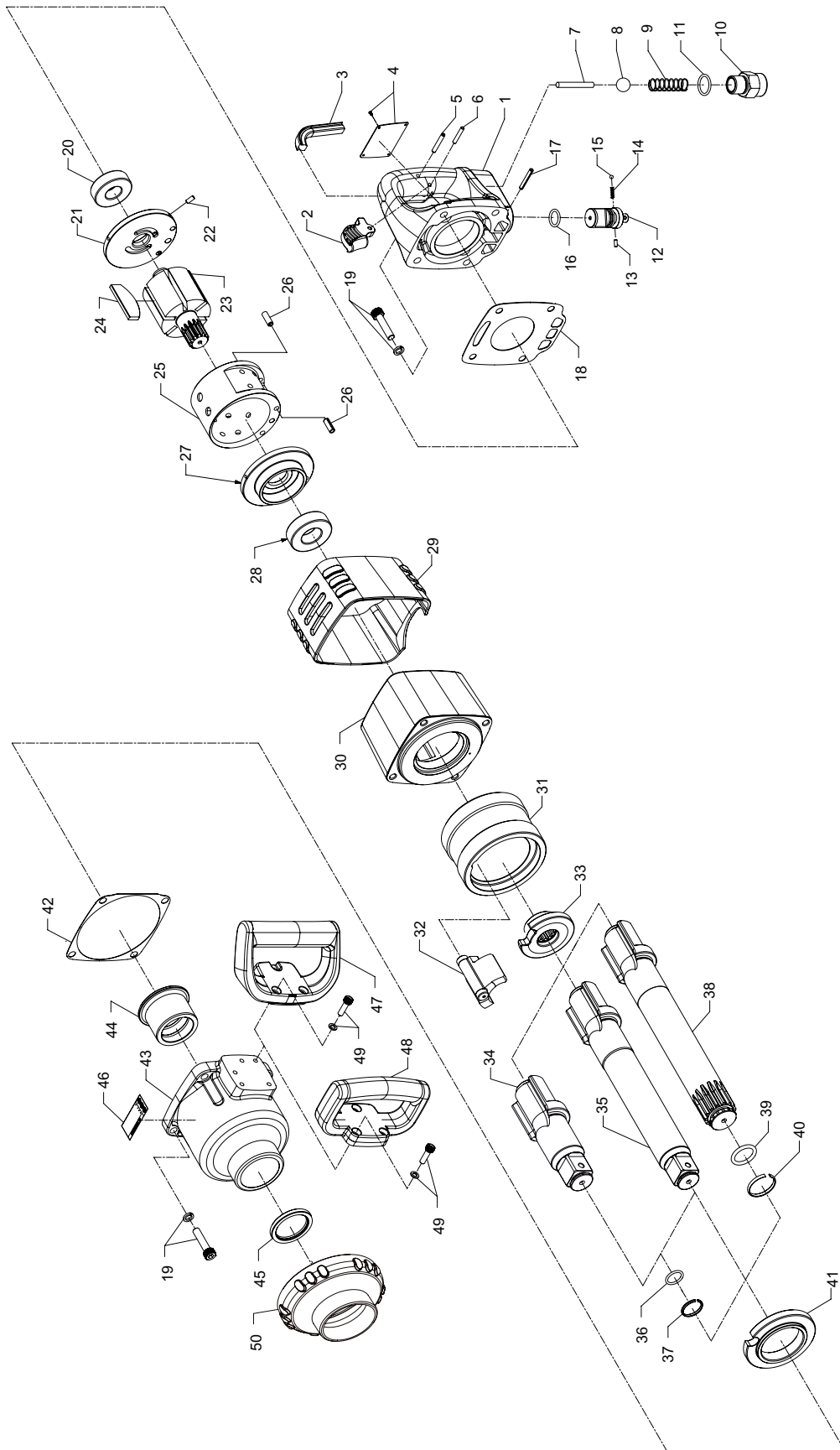

285B Series, Air Impact Wrench

Table 2. 285B Series, Air Impact Wrench - Parts List

Item	Part Description	Part Number
1	Trigger Handle Assembly	285B-A92A
2	Trigger	285B-93A
3	Slot Cover	285B-438
4	Nameplate and 4 rivets	
	(for 285B, 285B-6, 285B-S6, and 285B-6-AP)	285B-A301
	(for 285B-A and 285B-6A)	285B-A-A301
5	Stop Pin	285B-439
6	Pin, Spring	285B-437
7	Plunger, Throttle Valve	285B-302
8	Throttle Valve	285B-50
9	Spring, Throttle Valve	285B-51
10	Inlet Bushing Assembly	285B-A565
11	O-Ring	285B-566
12	Reverse Valve Assembly	285B-A329
13	Stop Pin	285B-332
14	Spring	285B-334
15	Ball	285B-333
16	Reverse Valve Seal	285B-338
17	Pin, Spring	285B-120
18	Gasket, Handle	285B-283
19	Handle Capscrew and Washer (set of 8)	285B-A638
20	Rear Rotor Bearing	285B-24
21	End Plate with alignment pin	285B-A12
22	Pin, Spring	—
23	Rotor	285B-53
24	Vane Pack (set of 6)	285B-42-6
25	Cylinder and alignment pins	285B-A3
26	Pin, Spring	—
27	Front End Plate	285B-11
28	Front Rotor Bearing	285B-96
29	Tool Guard	431L-32
30	Motor Housing	285B-40
31	Hammer Frame	285B-703
32	Hammer	285B-724
33	Hammer Cam	285B-721
34	Anvil Assembly	
	Standard length	285B-A726
35	6" Extended length	285B-A726-6
36	O-Ring	BBFM-557
37	Retainer Ring	910E5-918
38	6" Extended, #5 Spline	285B-A526-6
39	O-Ring	285B-S-557
40	Retainer Ring	285B-S-918
41	Side Plate	285B-706
42	Hammer Case Gasket	285B-36
43	Hammer Case Assembly	285B-A727

Table 2. 285B Series, Air Impact Wrench - Parts List (continued)

Item	Part Description	Part Number
44	Hammer Case Bushing	285B-641
45	Oil Seal	285B-642
46	Warning Label	WARNING-2-99
47	Dead Handle (angled) with screws	285B-A48-6
48	Dead Handle (straight) with screws	285B-A48
49	Screw and Washer (set of 3)	—
50	Hammer Case Guard	431L-62
-	Tune up Kit (includes 3, 7, 8, 9, 11, 13, 14, 15, 16, 17, 18, 20, 24, 28, 36, 37, 42, and 45)	285B-TK1

