



SERVICE PARTS LIST

BULLETIN NO.
54-26-2585

SPECIFY CATALOG NO. AND SERIAL NO. WHEN ORDERING PARTS		REVISED BULLETIN	DATE
M12™ FUEL™ 1/2" Impact Wrench w/ Friction Ring			June 2024
CATALOG NO.	2563-20	WIRING INSTRUCTION	
STARTING SERIAL NO.	P50A	See Page 2	

EXAMPLE:

00	0
----	---

 Component Parts (Small #)
 Are Included When Ordering
 The Assembly (Large #).

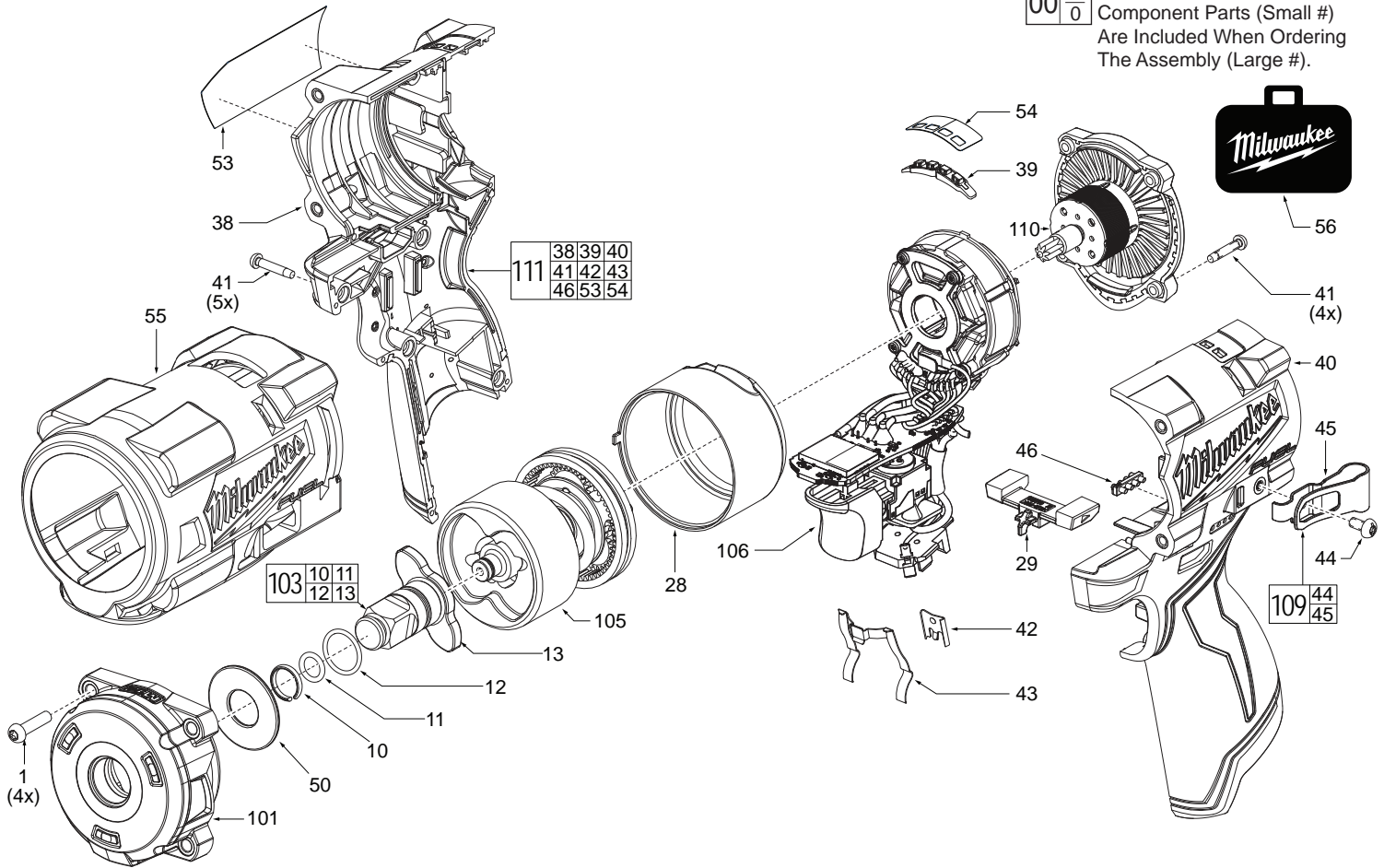
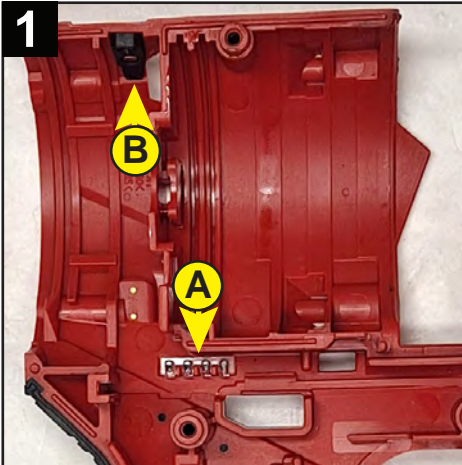

FIG.	PART NO.	DESCRIPTION OF PART	NO. REQ.
1	05-74-7130	M4 x 16mm Pan Hd. T-20 Screw	(4)
10	44-90-4530	1/2" Friction Ring	(1)
11	34-40-0900	O-Ring	(1)
12	-----	O-Ring	(1)
13	-----	1/2" Anvil	(1)
28	45-22-0054	Rubber Sleeve	(1)
29	45-24-0047	Forward/Reverse Shuttle	(1)
38	-----	Right Housing Halve - Cover	(1)
39	23-28-0228	Mode Select Light Pipe	(2)
40	-----	Left Housing Halve - Support	(1)
41	06-82-6351	M3 x 16mm Pan Hd. ST T-10 Screw	(9)
42	42-70-0058	Housing Connection Clip	(1)
43	42-70-0480	Leaf Spring	(1)
44	-----	#6-32 Pan Hd. T-15/Slot Screw	(1)
45	-----	Belt Clip	(1)
46	23-28-0229	Fuel Gauge Light Pipe	(1)
50	-----	Front Gear Case Washer	(1)
53	12-20-1412	Service Nameplate	(1)
54	-----	Trigger Mode Select Label	(1)
55	49-16-2562	Rubber Boot (Optional, Accessory)	(1)
56	42-55-3400	Zippered Tool Bag	(1)
101	28-50-0917	1/2" Gear Case Assembly	(1)
102	42-06-0322	1/2" Friction Ring Anvil Assembly	(1)
105	14-30-1226	Impacting Assembly	(1)
106	14-20-0253	Electronics Assembly	(1)
109	42-70-0497	Belt Clip Service Kit	(1)
110	16-01-2563	Rotor/Back Cap Assembly	(1)
111	31-44-0316	Housing Service Kit	(1)

- FIG. LUBRICATION**
(Type 'J' Grease, No. 49-08-4220):
- When servicing, remove 90-95% of the existing grease prior to installing Type 'J'. Original grease may be similar in color but not compatible with 'J'.**
- 101 Coat anvil opening in the front of the gear case with grease.
 - 103 Lightly coat round shaft surface of anvil with grease. Place a dab of grease in cavity at rear of anvil.
 - 105 Lightly coat the inside gear teeth of ring gear and ring gear hole, surface of the hammer, and the gear teeth of the planet gears of impacting assembly with grease.
 - 110 Coat pinion of rotor/back cap assembly with grease.

SCREW TORQUE SPECIFICATIONS				
FIG.	PART NO.	WHERE USED	SEAT TORQUE	
			(kgf-cm)	(lb-in)
1	05-74-7130	Front Gear Case	45±3	39±3
41	06-82-6351	Rotor/Back Cap	7±1	6±1
41	06-82-6351	Right Housing-Cover	10±1	9±1
44	-----	Belt Clip	16±2	14±2

WIRING/ELECTRONICS ASSEMBLY INSTRUCTIONS



Insert fuel gauge light pipe (A) and mode select light pipe (B) into the slots on the handle.

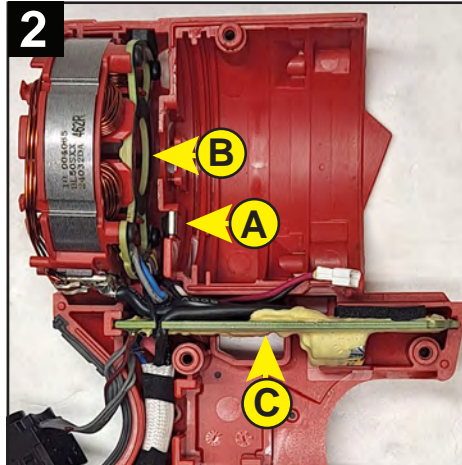

Place HV terminal wire clip on housing ridge (A). Insert electronics assembly into slots for stator (B) and PCBA board (C) into housing cavity as shown.

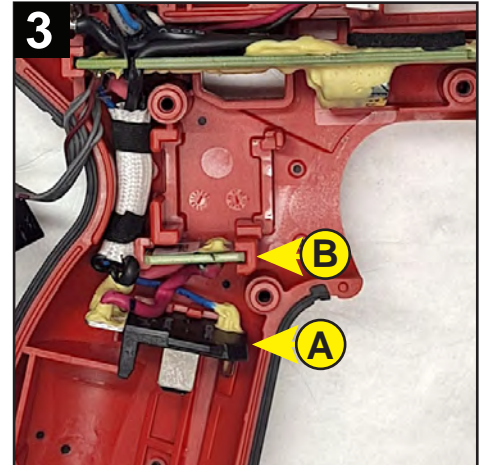

Route wires and place battery terminal (A) and hall board (B) into slots as shown, being sure that they are firmly and squarely seated in the cavities.

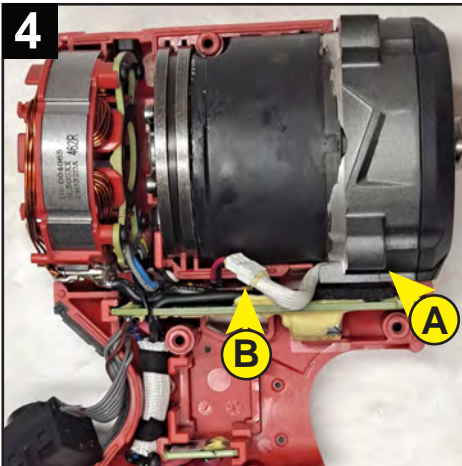

Place gearcase assembly into proper location (A). Attach white wire connectors together (B).

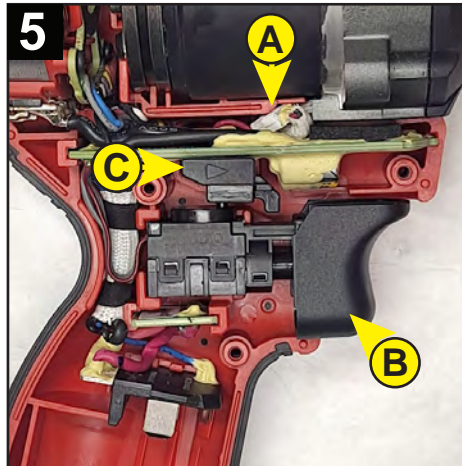

Be sure to tuck wire connectors into wire channel (A). Place trigger switch (B) and shuttle (C) into housing cavities.

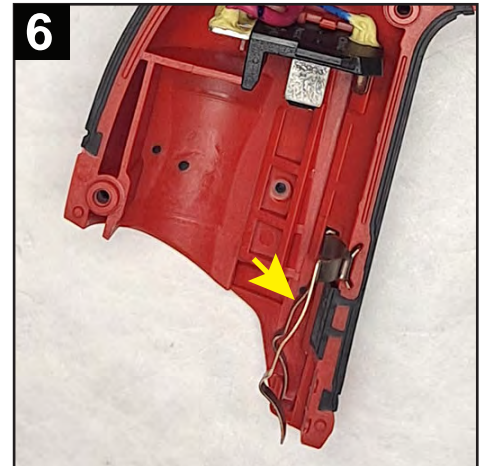

Insert leaf spring (fig.43) into bottom left handle half slots as shown.

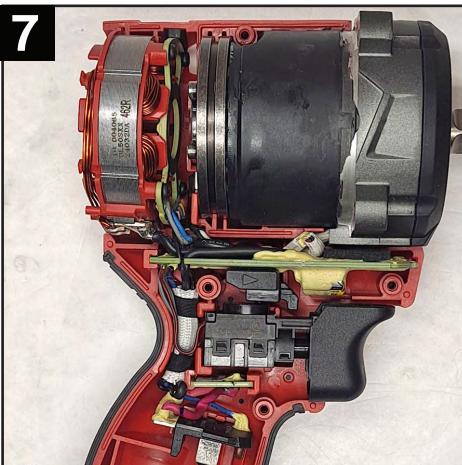

Check that all elements of electronics assembly are seated properly and that all wires are pressed completely down in wire traps and channels.



Carefully install right housing cover onto left housing support and secure with five housing half T-10 screws (fig.41). Check functionality of shuttle and on-off switch.



(A) Secure gearcase assembly to housing with four T-20 screws (fig.1). (B) Install rotor/back cap assembly and secure with four T-10 screws (fig.41).