

SUBMERSIBLE SOLIDS HANDLING PUMP

Series: 2BSE-SS
0.5 & 0.75 HP / 1750 RPM
Discharge: 2" or 3"
Spherical solids handling: 2"



DISCHARGE

2" or 3" NPT female, vertical, bolt on flange.

LIQUID TEMPERATURE

104°F (40°C) continuous

VOLUTE

Cast iron ASTM A-48 class 30

MOTOR HOUSING

Cast iron ASTM A-48 class 30

SEAL PLATE

Cast iron ASTM A-48 class 30

IMPELLER

Design: 2 vane, open, with vanes on back side.

Material: cast iron ASTM A-48 class 30

SHAFT

416 series stainless steel

HARDWARE

300 series stainless steel

SQUARE RINGS

Buna-N

PAINT

Air dry enamel, water based.

SEAL

Design: inboard single mechanical, oil filled chamber.

Material: silicon carbide, Buna-N elastomer and stainless steel hardware.

CORD ENTRY

30 ft of neoprene cord SJO 14/3, sealed against moisture.

BEARINGS

Upper: ball, single row, oil lubricated, for radial load.

Lower: ball, single row, oil lubricated, for radial and thrust load.

MOTOR

Single phase: NEMA L, permanent split capacitor, 115 & 230 volts, 60 Hz, 1750 RPM, oil filled, overload protection in motor.

Three phase: NEMA B, 200/230 & 460 volts, 60 Hz, 1750 RPM, oil filled. Requires overload protection to be included in control panel.

OPTIONAL EQUIPMENT

Additional cord, tungsten carbide seal. **Includes 3" discharge flange.**

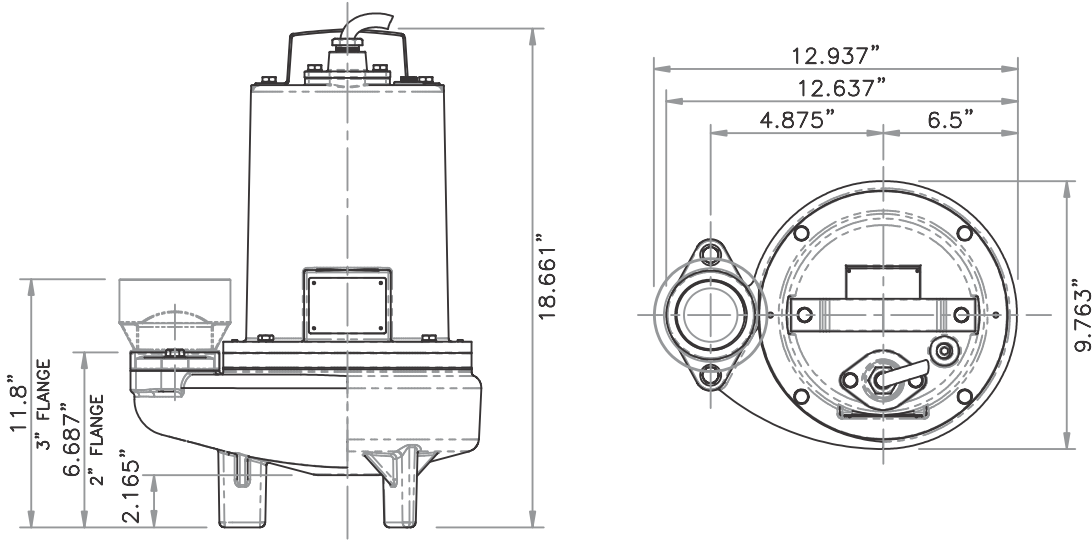

MODEL	PART No.	HP	VOLTS	PHASE	RPM (Nominal)	MAX AMPS	LOCKED ROTOR AMPS	NEMA CODE	CORD SIZE	CORD TYPE	CORD O.D.	WEIGHT (pounds)
2BSE51SS	62180501	0.5	115	1	1750	11.6	18.4	D	14/3	SJO	0.5"	91
2BSE51A	62180501A	0.5	115	1	1750	11.6	18.4	D	14/4	SJO	0.5"	93
2BSE52SS	62180502	0.5	200/230	1	1750	5.9	14.9	B	14/3	SJO	0.5"	93
2BSE53SS	62180503	0.5	200/230	3	1750	4.6/4.2	9.7/11.1	K	14/3	SJO	0.5"	95
2BSE54SS	62180504	0.5	460	3	1750	2.2	5.3	K	14/3	SJO	0.5"	95
2BSE72SS	62180505	0.75	230	1	1750	10.5	17.5	D	14/3	SJO	0.5"	95
2BSE73SS	62180506	0.75	200/230	3	1750	5.5	16	D	12/4	SJO	0.625"	96
2BSE74SS	62180507	0.75	460	3	1750	2.2	8	D	12/4	SJO	0.625"	96

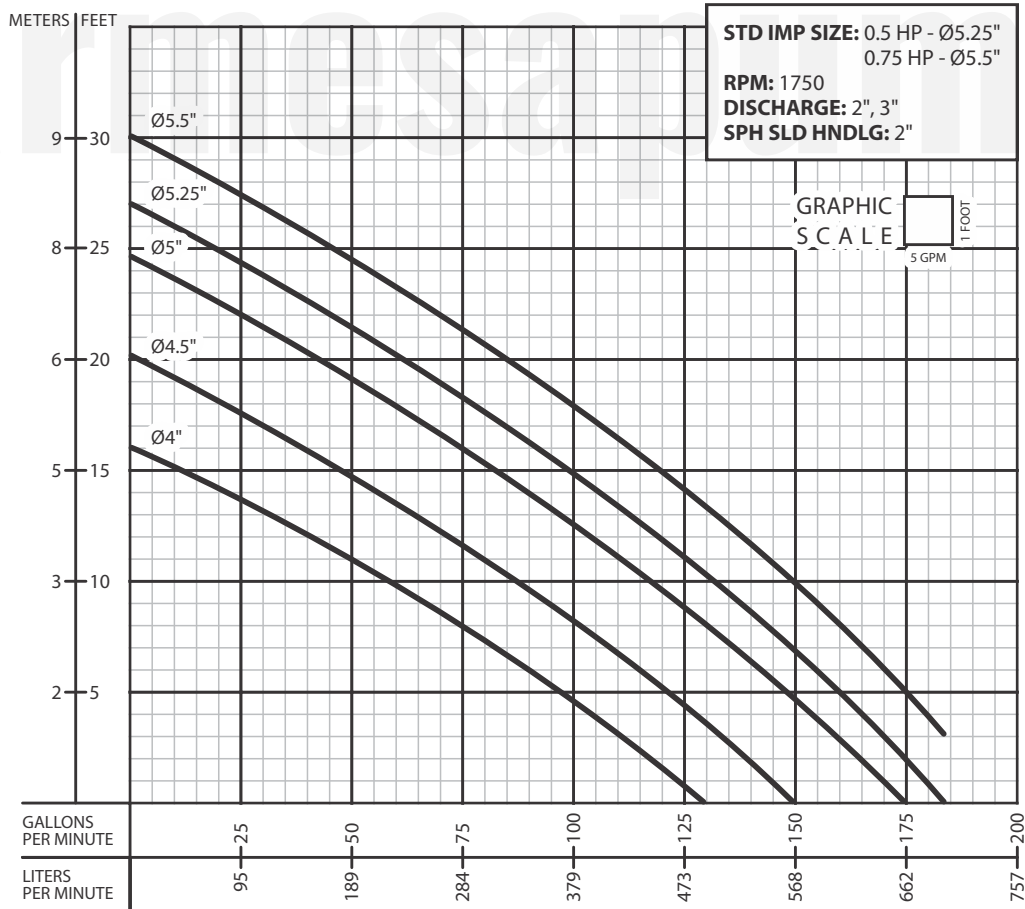

IMPORTANT!

1. Never use this pump to handle explosive liquids.
2. This pump is not approved to be used in swimming pools, recreational installations or any application where human contact may be common.
3. Pump may be operated "dry" for extended periods without damage to motor and/or seals.
4. Testing is performed with water specific gravity of 1.0 @ 68 °F (20 °C); other fluids may vary performance.