

# SUBMERSIBLE SOLIDS HANDLING PUMP

Series: 4BSE-SS  
3 & 5 HP / 1750 RPM  
Discharge: 4"  
Spherical solids handling: 3"



## DISCHARGE

4", 125 lb, flange horizontal.

## LIQUID TEMPERATURE

104°F (40°C) continuous

## VOLUTE

Cast iron ASTM A-48 class 30

## MOTOR HOUSING

Cast iron ASTM A-48 class 30

## SEAL PLATE

Cast iron ASTM A-48 class 30

## IMPELLER

**Design:** 2 vane, open, with vanes on back side.

**Material:** cast iron ASTM A-48 class 30

## SHAFT

416 series stainless steel

## HARDWARE

300 stainless steel

## SQUARE RINGS

Buna-N

## PAINT

Air dry enamel, water based.

## SEAL

**Design:** inboard, single mechanical, oil filled chamber.

**Material:** silicon carbide, Buna-N elastomer and stainless steel hardware.

## CORD ENTRY

40 ft of neoprene cord SO 3x10 for single phase and 4x10 for three phase pumps, sealed against moisture.

## BEARINGS

**Upper:** ball, single row, oil lubricated, for radial load.

**Lower:** ball, single row, oil lubricated, for radial and thrust load.

## MOTOR

**Single phase:** NEMA L, permanent split capacitor, 200/230 volts, 60 Hz, 1750 RPM, oil filled, overload protection in motor.

**Three phase:** NEMA B, 208/230 & 460 volts, 60 Hz, 1750 RPM, oil filled. Requires overload protection to be included in control panel.

## OPTIONAL EQUIPMENT

Additional cord, slide rail coupling (SRC-4).

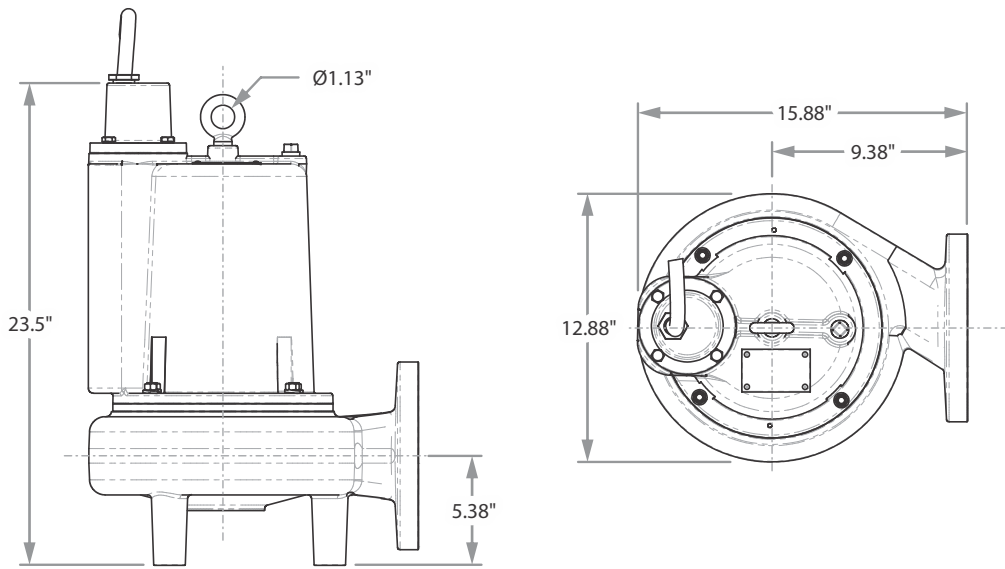

MODEL	PART No.	HP	VOLTS	PHASE	RPM (Nominal)	MAX AMPS	LOCKED ROTOR AMPS	NEMA CODE	CORD SIZE	CORD TYPE	CORD O.D.	WEIGHT (pounds)
4BSE302SS	62170101	3	230	1	1750	18.5	23	D	3x10	SO	0.75"	201
4BSE303SS	62170102	3	230	3	1750	15	44	D	4x10	SO	0.75"	201
4BSE304SS	62170103	3	460	3	1750	7.5	22	D	4x10	SO	0.75"	201
4BSE502SS	62170104	5	230	1	1750	28	56	D	3x10	SO	0.75"	201
4BSE503SS	62170105	5	230	3	1750	19	56	D	4x10	SO	0.75"	201
4BSE504SS	62170106	5	460	3	1750	9.5	28	D	4x10	SO	0.75"	201

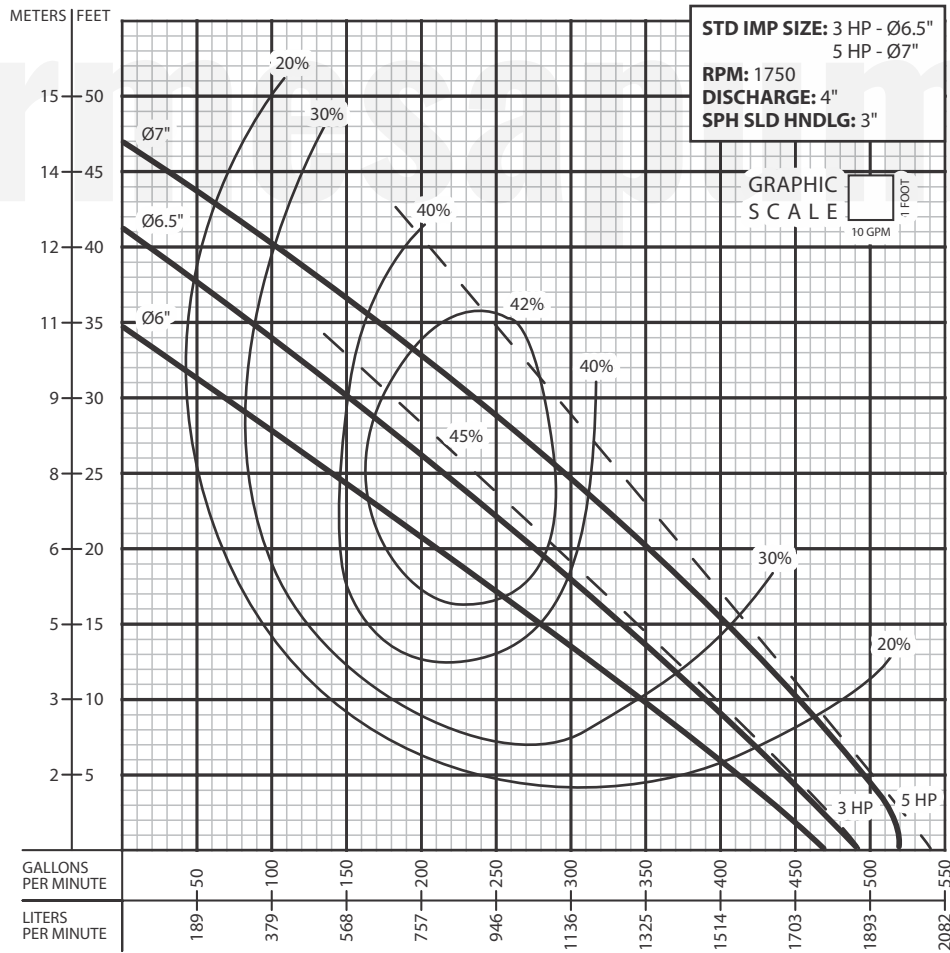

**IMPORTANT!**

1. Never use this pump to handle explosive liquids.
2. This pump is not approved to be used in swimming pools, recreational installations or any application where human contact may be common.
3. Pump may be operated "dry" for extended periods without damage to motor and/or seals.
4. Testing is performed with water specific gravity of 1.0 @ 68 °F (20 °C); other fluids may vary performance.