

SUBMERSIBLE GRINDER PUMP

Series: BGP-DS
2 HP
3500 RPM
Discharge: 1¼"



DISCHARGE
1¼" NPT, vertical.

LIQUID TEMPERATURE
Continuous: 120 °F (48 °C)
Intermittent: 140 °F (60 °C)

VOLUTE
Cast iron ASTM A-48, class 30.

MOTOR HOUSING
Cast iron ASTM A-48, class 30.

SEAL PLATE
Cast iron ASTM A-48, class 30.

IMPELLER
Design: 12 vanes, vortex with vanes on back side, dynamically balanced.
Material: Cast iron ASTM A-48, class 30.
Radial cutter: hardened 440C, stainless steel, hardness Rockwell C-55.
Shredding ring: hardened 440C, stainless steel, hardness Rockwell C-55.

SHAFT
420 series stainless steel

HARDWARE
Stainless steel

O-RINGS
Buna-N

PAINT
Air dry enamel, water based.

SEAL
Design: double seal, oil lubricated.
Material: ceramic stationary part, carbon ring seal and exclusion in the rotating part, and silicon-silicon in the secondary (pump) seal. Buna-N elastomer and stainless steel spring.

CORD ENTRY
30 ft of neoprene cord, sealed against moisture.

BEARINGS
Ball, single row, oil lubricated.

MOTOR
Single phase: permanent split capacitor, 230 volts, 60 Hz, 3500 RPM, oil filled, with overload protection in motor. Class F insulation. Model BGP202DS requires capacitors and relay to be installed in control panel. Model BGPC202DS offers internal capacitor design.
Three phase: 230 & 460 volts, 60 Hz, 3500 RPM, oil filled, with overload protection in motor. Class F insulation.

MOISTURE SENSOR
Normally open (N/O) included

TEMPERATURE SENSOR
Normally closed (N/C). It requires a relay in the control panel.

NOTE
Leg kit is provided with each pump. Installer has the option of using the leg kit or may choose to utilize an SRC125 Slide Rail System with base.

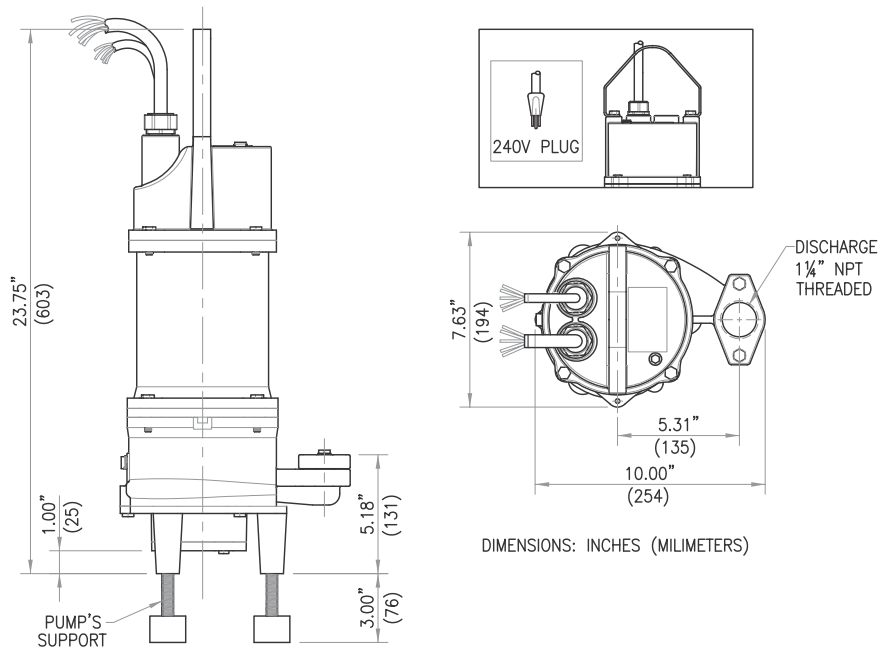

| MODEL | PART No. | HP | PH | V | A | LOCKED ROTOR AMPERAGE | CORD SIZE | CORD TYPE | INTERNAL CAPACITOR | MOISTURE SENSOR | WEIGHT (lb) |
|-------------------------|----------|----|----|---------|---------|-----------------------|-----------|-----------|--------------------|-----------------|-------------|
| BGP202DS ¹ | 72100101 | 2 | 1 | 208/230 | 16/14.5 | 23 | 12/3 | SOOW | No | Yes | 130 |
| BGP203DS | 72100102 | 2 | 3 | 208/230 | 9.8/8.8 | 22.5 | 12/4 | SOOW | n/a | Yes | 130 |
| BGP204DS | 72100103 | 2 | 3 | 460 | 4.4 | 11.3 | 12/4 | SOOW | n/a | Yes | 130 |
| BGPC202DS | 72100104 | 2 | 1 | 208/230 | 16/14.5 | 23 | 12/3 | SOOW | Yes | No | 130 |
| BGPC202DSA ² | 72100105 | 2 | 1 | 208/230 | 16/14.5 | 23 | 12/3 | SOOW | Yes | No | 130 |

¹ Includes the capacitor and relay kit with the pump

² Includes the level control with the pump

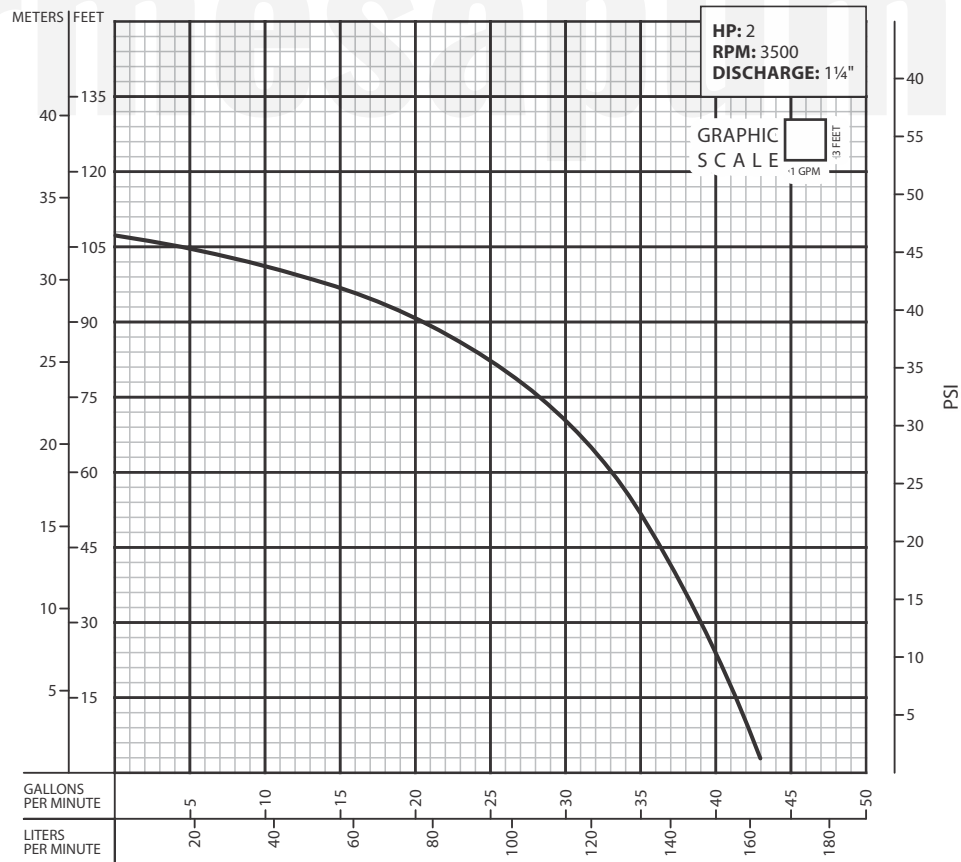

IMPORTANT!

1. Never use this pump to handle explosive liquids.
2. This pump is not approved to be used in swimming pools, recreational installations or any application where human contact may be common.
3. Pump may be operated "dry" for extended periods without damage to motor and/or seals.
4. Testing is performed with water specific gravity of 1.0 @ 68 °F (20 °C); other fluids may vary performance.