

SUBMERSIBLE EFFLUENT PUMP

Series: BPEV512
0.5 HP / 3500 RPM
Discharge: 2"
Spherical solids handling: 3/4"



DISCHARGE

2" NPT, female, vertical.

LIQUID TEMPERATURE

104 °F (40 °C) continuous

VOLUTE

Cast iron ASTM A-48 class 30

MOTOR HOUSING

Cast iron ASTM A-48 class 30

IMPELLER

Design: vortex.

Material: cast iron ASTM A-48 class 30, dynamically balanced, ISO G6.3.

SHAFT

416 series stainless steel

O-RINGS

Square shaped Buna-N

PAINT

Air dry enamel, water based.

SEAL

Design: single, mechanical, oil filled chamber.

Material: carbon / ceramic / Buna-N, with stainless steel hardware.

HARDWARE

300 series stainless steel

CORD ENTRY

30 ft of neoprene cord SJTOW 16/3, sealed against moisture.

BEARINGS

Upper: ball, single row, oil lubricated, for radial load.

Lower: ball, single row, oil lubricated, for radial load.

MOTOR

NEMA L, single phase, permanent split capacitor, 115 volts, 60 Hz, 3500 RPM, oil filled, with overload protection in motor.

PUMP OPERATION

Manual or automatic float switch

OPTIONAL EQUIPMENT

Additional cord, slide rail coupling (SRC200).

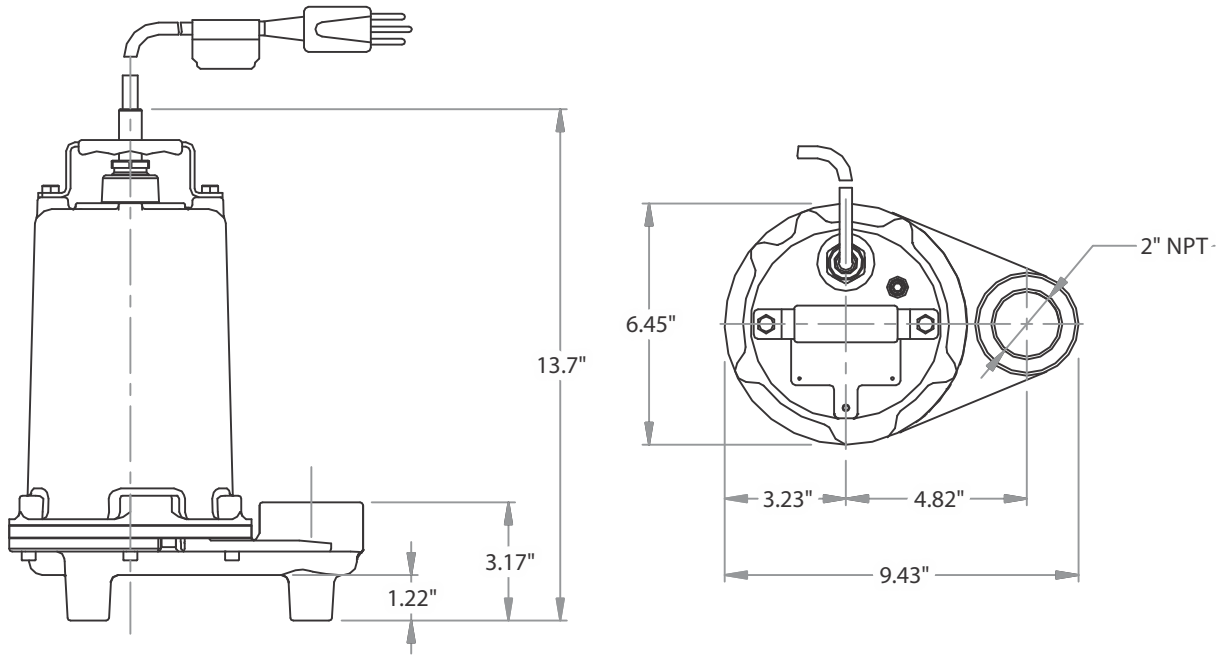

MODEL	PART No.	HP	VOLTS	PHASE	RPM (Nominal)	MAX AMPS	LOCKED ROTOR AMPS	CORD SIZE	CORD TYPE	WEIGHT (pounds)
BPEV512	62180201	0.5	115	1	3500	8	16	16/3	SJTOW	50
BPEV512A	62180202	0.5	115	1	3500	8	16	16/3	SJTOW	49

A = Automatic Float Switch

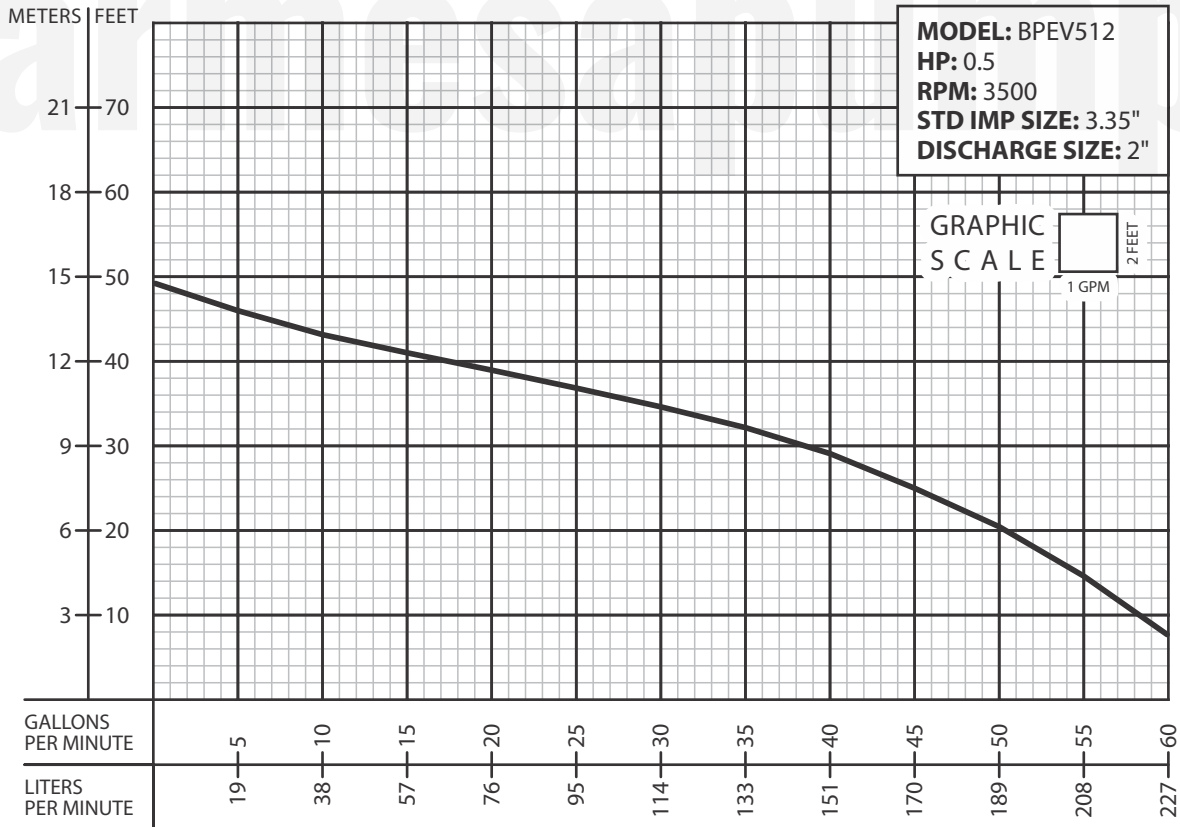

IMPORTANT!

1. Never use this pump to handle explosive liquids.
2. This pump is not approved to be used in swimming pools, recreational installations or any application where human contact may be common.
3. Pump may be operated "dry" for extended periods without damage to motor and/or seals.
4. Testing is performed with water specific gravity of 1.0 @ 68 °F (20 °C); other fluids may vary performance.