

BSP-CCE series

1.5, 2, 3, 5, 7.5, 10 & 15 HP
@ 3500 RPM

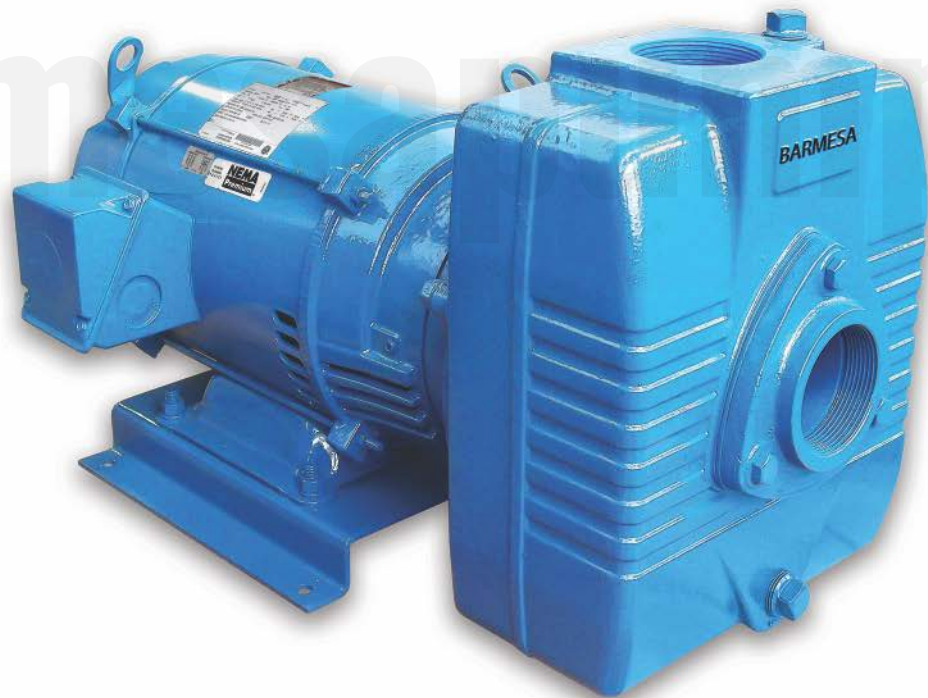

IMPORTANT! - Read all instructions in this manual before operating or servicing a pump.

Before installation, read the following instructions carefully. Failure to follow instruction and safety information could cause serious bodily injury, death and/or property damage. Each Barmesa product is carefully inspected to insure proper performance. Closely following these instructions will eliminate potential operating problems, assuring years of trouble-free service.

⚠ DANGER "Danger" indicates an imminently hazardous situation which, if not avoided, WILL result in death or serious injury.

⚠ WARNING "Warning" indicates an imminently hazardous situation which, if not avoided, MAY result in death or serious injury.

⚠ CAUTION "Caution" indicates a potentially hazardous situation which, if not avoided, MAY result in minor or moderate injury.

IMPORTANT! - Barmesa Pumps is not responsible for losses, injury or death resulting from failure to observe these safety precautions, misuse, abuse or misapplication of pumps or equipment.

⚠ ALL RETURNED PRODUCTS MUST BE CLEANED, SANITIZED, OR DECONTAMINATED PRIOR TO SHIPMENT, TO INSURE EMPLOYEES WILL NOT BE EXPOSED TO HEALTH HAZARDS IN HANDLING SAID MATERIAL. ALL APPLICABLE LAWS AND REGULATIONS SHALL APPLY.

⚠ WARNING Installation, wiring, and junction connections must be in accordance with the National Electric Code and all applicable state and local codes. Requirements may vary depending on usage and location.

⚠ WARNING Installation and servicing is to be conducted by qualified personnel only.

 Keep clear of suction and discharge openings. Do not insert fingers in pump with power connected; the impeller can cause serious injury.

 Always wear eye protection when working on pumps. Do not wear loose clothing that may become entangled in moving parts.

⚠ DANGER Pumps build up heat and pressure during operation. Allow time for pumps to cool before handling or servicing the pump or any accessory items associated with or near the pump.

⚠ DANGER This pump is not intended for use in swimming pools or water installations where there is human contact with pumped fluid.

⚠ DANGER Risk of electric shock. To reduce risk of electric shock, always disconnect pump from power source before handling any aspect of the pumping system. **Lock out power and tag.**

⚠ WARNING Do not use these pumps in water over 160° F. Do not exceed manufacturers recommended maximum performance, as this could cause the motor to overheat.

⚠ DANGER Operation against a closed discharge valve will cause premature bearing and seal failure.

Heat build up on self-priming and end suction pumps may cause dangerous pressures. A high temperature switch or pressure relief valve is recommended to be installed in pump case.

⚠ WARNING Carefully read instruction manuals supplied with motor or engine before operating or servicing.

⚠ WARNING Pumps constructed with or fitted with bronze/brass may contain lead levels higher than considered safe for potable water systems. Lead is known to cause cancer and birth defects or other reproductive harm. Various government agencies have determined that leaded copper alloys should not be used in potable water applications.

⚠ DANGER These pumps are not to be installed in locations classified as hazardous in accordance with the National Electric Code, ANSI/NFPA 70.

IMPORTANT! - Prior to installation, record Model Number, Serial, Amps, Voltage, Phase and HP from pump name plate for the future reference. Also record the Voltage and Current Readings at Startup:

Model Number: _____

Serial: _____

Amps: _____ Voltage: _____

Phase: _____ HP: _____

SUCTION/DISCHARGE:	1½", 2" & 3" NPT, female.
LIQUID TEMPERATURE:	160°F (71°C) max.
INTERMEDIATE:	Cast iron ASTM A-48 class 30.
VOLUTE:	Cast iron ASTM A-48 class 30.
BODY:	Cast iron ASTM A-48 class 30.
BASE:	Steel
IMPELLER:	2 vane, open, trash type, dynamically balanced. Cast iron ASTM A-48 class 30.
SHAFT:	416 series stainless steel.
HARDWARE:	Steel & stainless steel.
SQUARE RINGS:	Buna-N.
PAINT:	Air dry enamel, water based.
SEAL:	Mechanical, self lubrication. Ceramic stationary part, carbon ring seal and exclusion in the rotating part. Buna-N elastomer and stainless steel spring.
CHECK VALVE:	Flap-neoprene. Steel.
MOTOR:	Open Drip Proof or TEFC, C-face, footed, squirrel cage induction, class B or F insulation. Single phase: 115/230 volts, 60 Hz, 3450 RPM. Three phase: 230/460 volts, 60 Hz, 3450 RPM.
OPTIONAL EQUIPMENT:	Bronze fitted volute and impeller.

barmesapumps

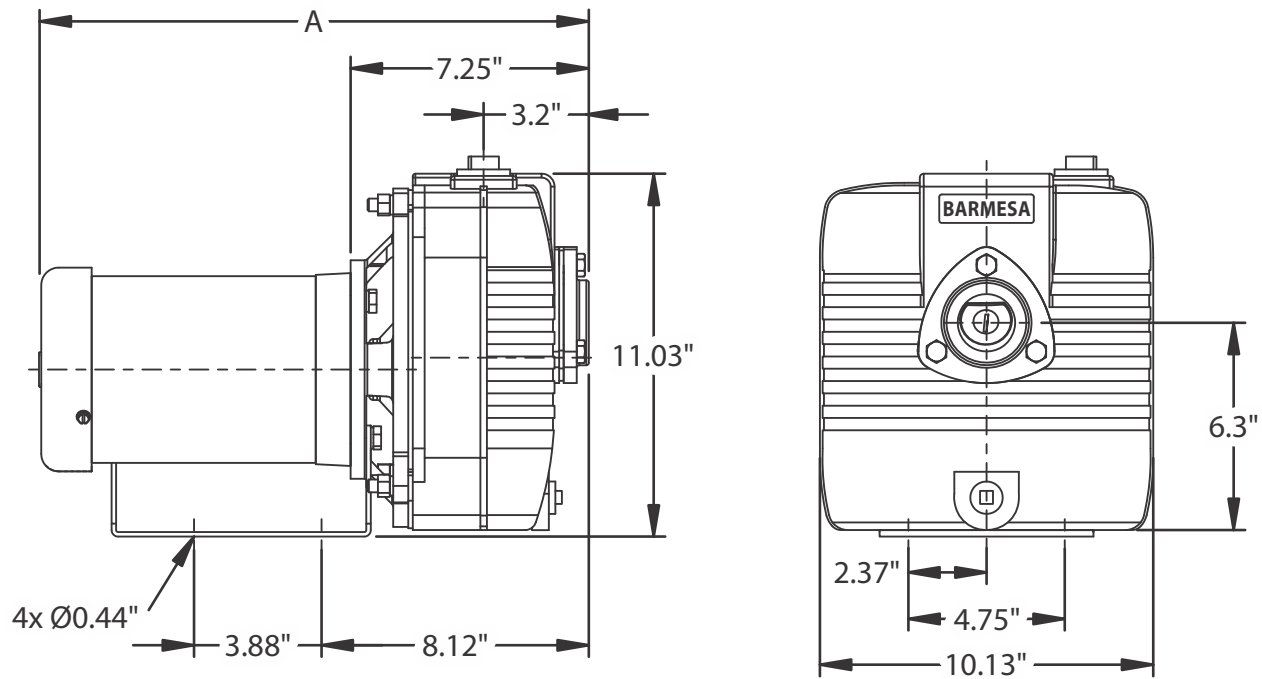

MODEL	PART No.	HP	PHASE	VOLTS	ENCLOSURE	MAX AMPS	A (inches)	WEIGHT (pounds)
BSP3CCE1	62030001	1.5	1	115/230	ODP	13/6.5	18.58	91
BSP3CCE3	62030002	1.5	3	230/460	ODP	5.5 - 4.4/2.2	17.91	84
BSP3CCE1-BF	62030101	1.5	1	115/230	ODP	13/6.5	18.58	91
BSP3CCE3-BF	62030102	1.5	3	230/460	ODP	5.5 - 4.4/2.2	17.91	84
BSP3CCE3-T	62030022	1.5	3	230/460	TEFC	4.9 - 4.6/2.3	17.61	85
BSP3CCE3-TBF	62030122	1.5	3	230/460	TEFC	4.9 - 4.6/2.3	17.61	85
BSP4CCE1	62030003	2	1	115/230	ODP	26/13	17.93	101
BSP4CCE3	62030004	2	3	230/460	ODP	6.4 - 5.4/2.7	18.41	92
BSP4CCE1-BF	62030103	2	1	115/230	ODP	26/13	17.93	101
BSP4CCE3-BF	62030104	2	3	230/460	ODP	6.4 - 5.4/2.7	18.41	92
BSP4CCE1-T	62030023	2	1	115/230	TEFC	23/11.5	19.31	112
BSP4CCE3-T	62030024	2	3	230/460	TEFC	7.0 - 5.4/2.7	18.43	98
BSP4CCE1-TBF	-	2	1	115/230	TEFC	23/11.5	19.31	112
BSP4CCE3-TBF	62030124	2	3	230/460	TEFC	7.0 - 5.4/2.7	18.43	98
BSP5CCE1	62030005	3	1	115/230	ODP	29/14.5	18.81	105
BSP5CCE3	62030006	3	3	230/460	ODP	8.5/8.4	18.43	94
BSP5CCE1-BF	62030105	3	1	115/230	ODP	29/14.5	18.81	105
BSP5CCE3-BF	62030106	3	3	230/460	ODP	8.5/8.4	18.43	94
BSP5CCE1-T	62030025	3	1	115/230	TEFC	26/13	20.68	117
BSP5CCE3-T	62030026	3	3	230/460	TEFC	8.1 - 7.6/3.8	18.43	97
BSP5CCE1-TBF	62030123	3	1	115/230	TEFC	26/13	20.68	117
BSP5CCE3-TBF	62030125	3	3	230/460	TEFC	8.1 - 7.6/3.8	18.43	97

T = totally enclosed BF = bronze fitted TB = totally enclosed bronze fitted

* Overall length of unit and amps is subject to the motor manufacture.

DIMENSIONAL DRAWING SELF-PRIMING PUMP BSP10CCE

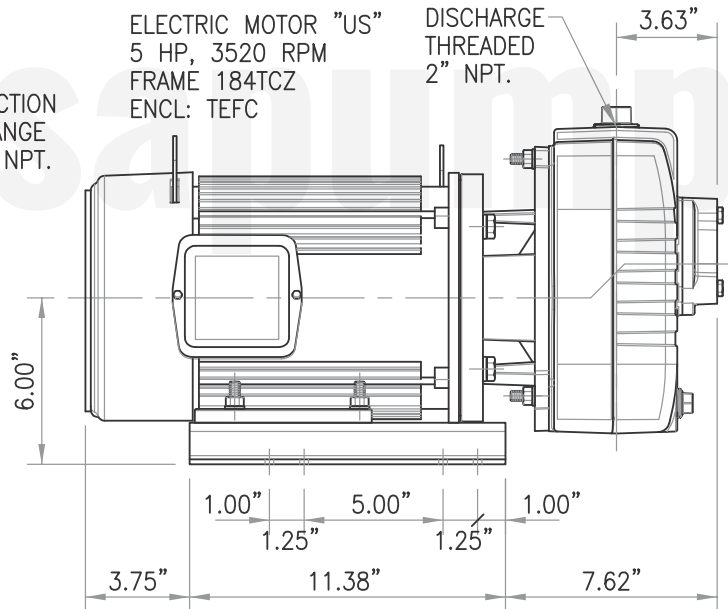
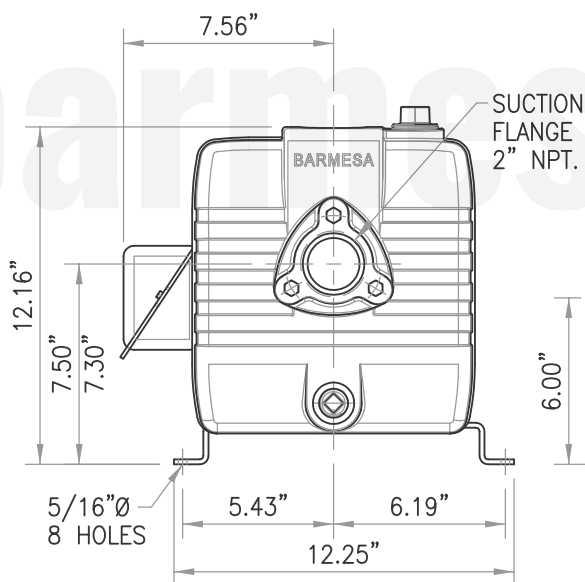
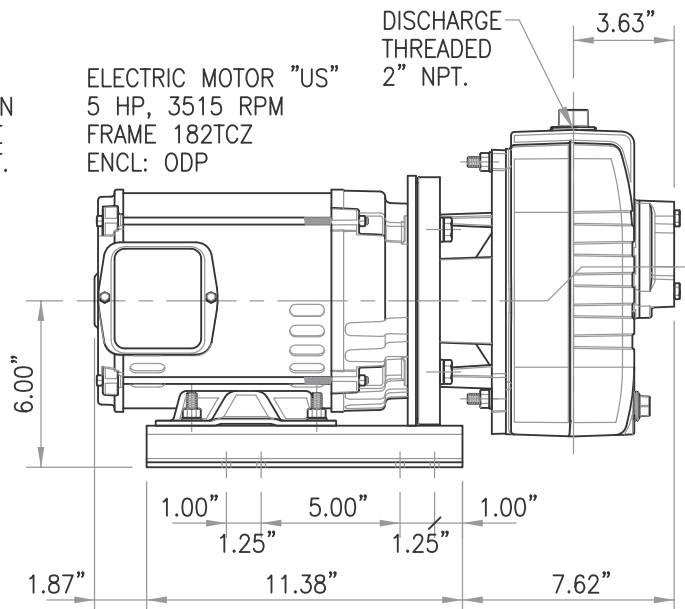
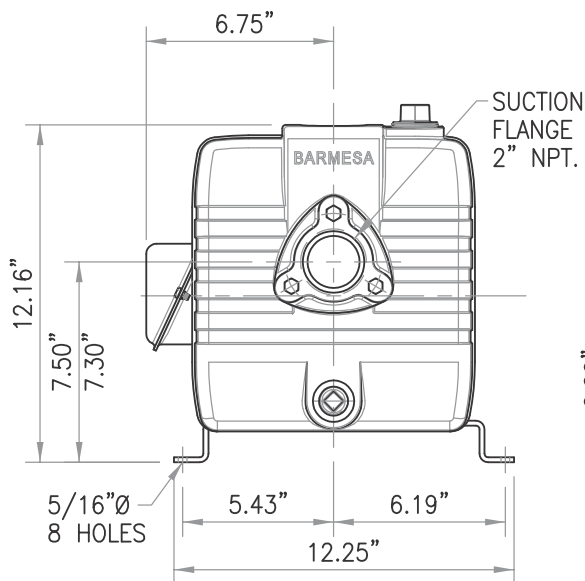

MODEL	PART No.	HP	PHASE	VOLTS	ENCLOSURE	MAX AMPS	A (inches)	WEIGHT (pounds)
BSP10CCE3	62030008	5	3	230/460	ODP	13.12/6	21.25	168
BSP10CCE3-BF	62030109	5	3	230/460	ODP	13.12/6	21.25	168
BSP10CCE3-T	62030027	5	3	230/460	TEFC	12.6-11.6/5.8	22.81	165
BSP10CCE3-TBF	62030129	5	3	230/460	TEFC	12.6-11.6/5.8	22.81	168

T = totally enclosed

BF = bronze fitted

TB = totally enclosed bronze fitted

* Overall length of unit and amps is subject to the motor manufacture.

DIMENSIONAL DRAWING SELF PRIMING PUMP BSP15CCE

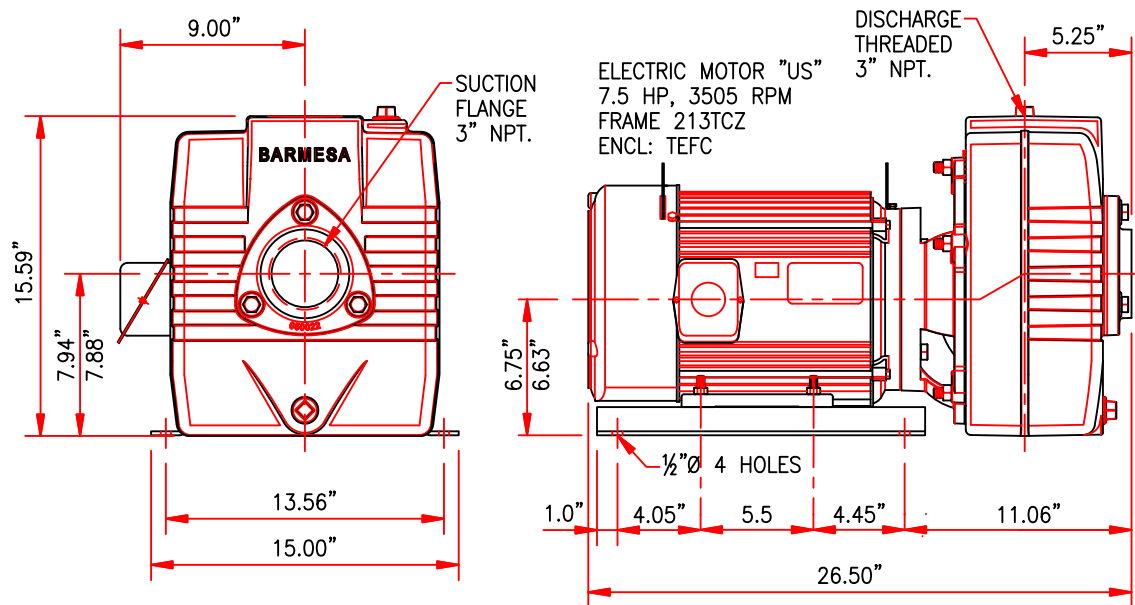

DIMENSIONS: INCHES
OVERALL DIMENSIONS SUBJECT TO MOTOR MANUFACTURER.

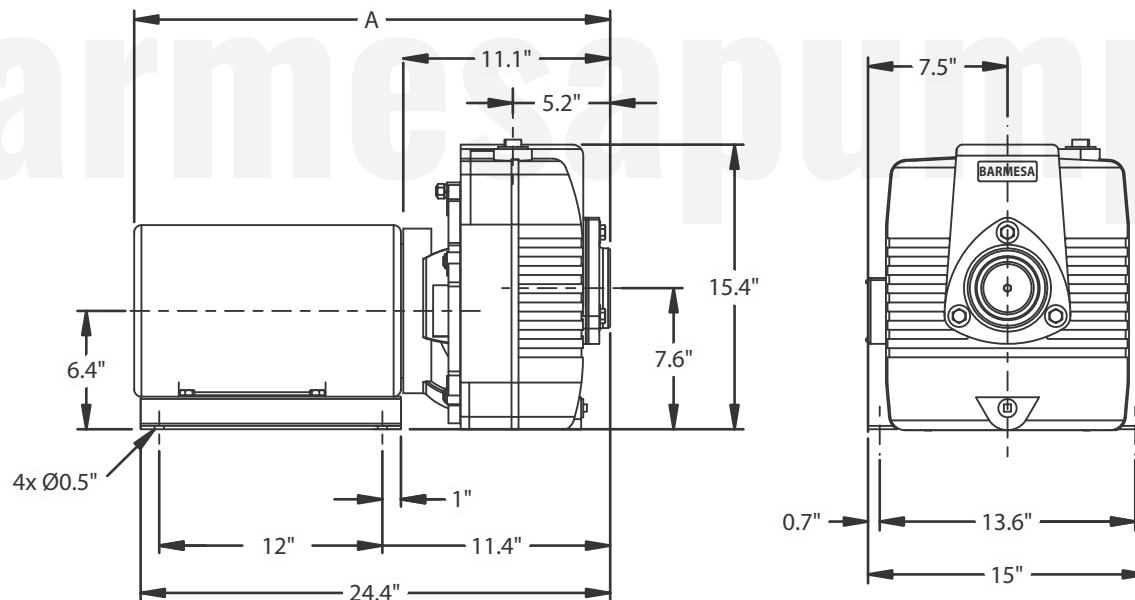

MODEL	PART No.	HP	PHASE	VOLTS	ENCLOSURE	MAX AMPS	A (inches)	WEIGHT (pounds)
BSP15CCE3	62030009	7.5	3	230/460	ODP	18.8-17.4/8.7	23.22	248
BSP15CCE3-BF	62030110	7.5	3	230/460	ODP	18.8-17.4/8.7	23.22	248
BSP15CCE3-T	62030029	7.5	3	230/460	TEFC	18.5-17.4/8.7	26.28	251
BSP15CCE3-TBF	62030130	7.5	3	230/460	TEFC	18.5-17.4/8.7	26.28	251

T = totally enclosed

BF = bronze fitted

TB = totally enclosed bronze fitted

* Overall length of unit and amps is subject to the motor manufacture.

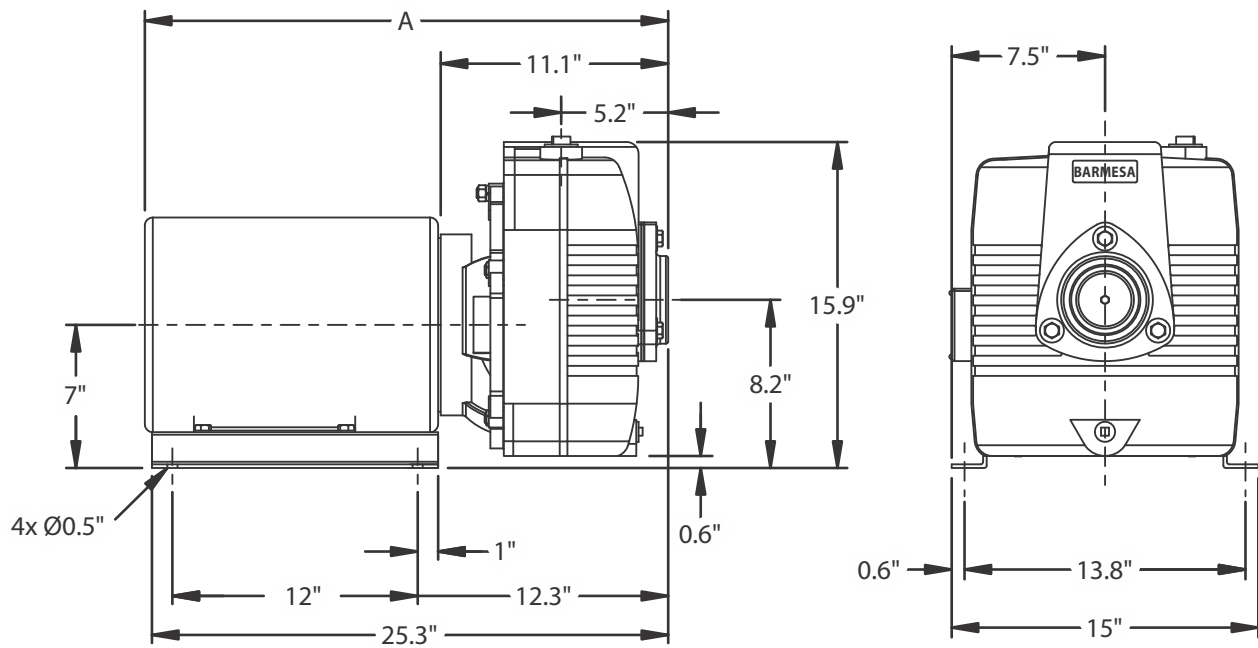

MODEL	PART No.	HP	PHASE	VOLTS	ENCLOSURE	MAX AMPS	A (inches)	WEIGHT (pounds)
BSP20CCE3	62030010	10	3	230/460	ODP	25.2-24/12	24.79	294
BSP20CCE3-BF	62030112	10	3	230/460	ODP	25.2-24/12	24.79	294
BSP20CCE3-T	62030030	10	3	230/460	TEFC	25-23/11.5	26.36	301
BSP20CCE3-TBF	62030131	10	3	230/460	TEFC	25-23/11.5	26.36	301

T = totally enclosed

BF = bronze fitted

TB = totally enclosed bronze fitted

* Overall length of unit and amps is subject to the motor manufacture.

DIMENSIONAL DRAWING SELF PRIMING PUMP BSP25CCE

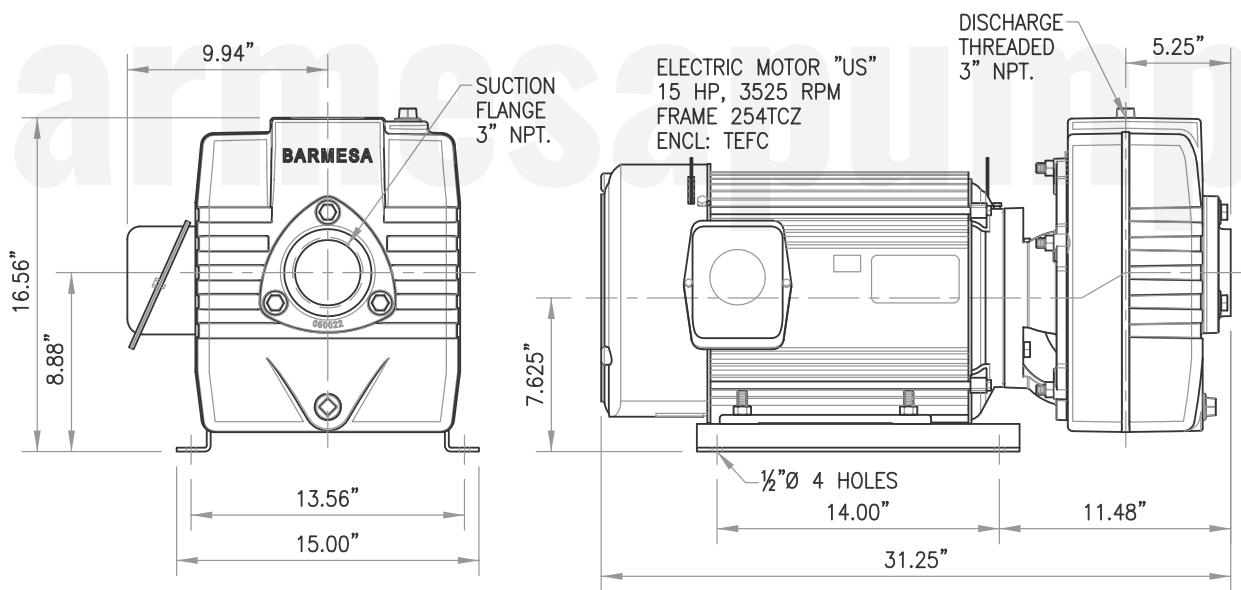
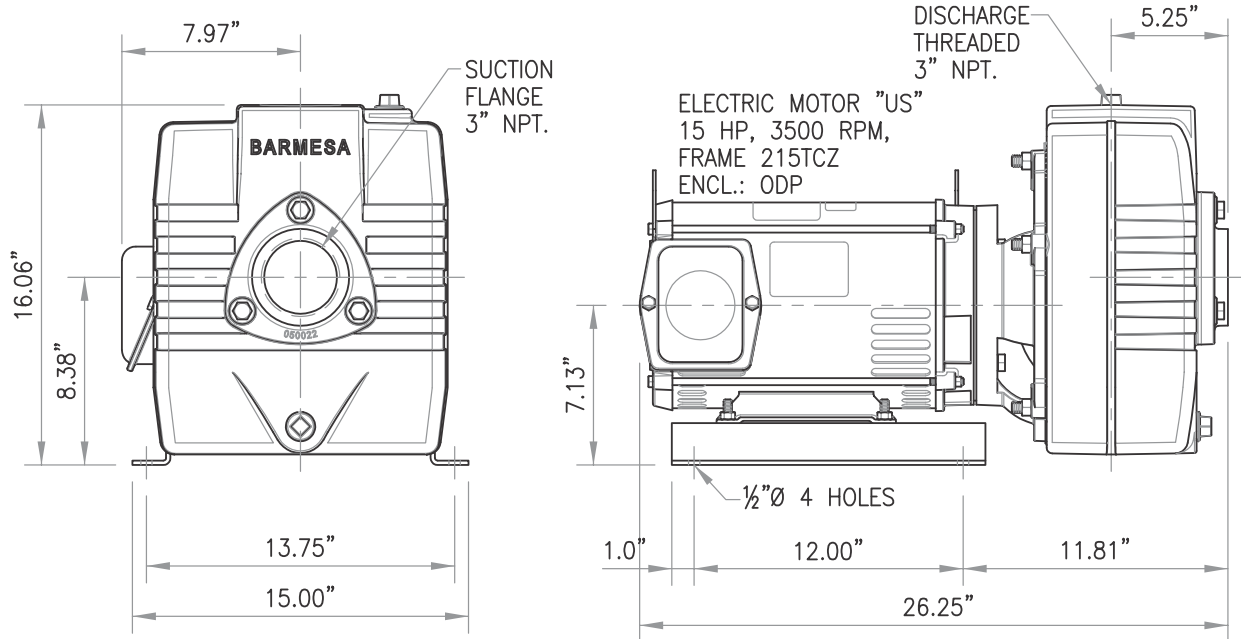

MODEL	PART No.	HP	PHASE	VOLTS	ENCLOSURE	MAX AMPS	A (inches)	WEIGHT (pounds)
BSP25CCE3	62030011	15	3	230/460	ODP	44-40/20	24.79	322
BSP25CCE3-BF	62030111	15	3	230/460	ODP	44-40/20	24.79	322
BSP25CCE3-T	62030031	15	3	230/460	TEFC	38-35/17.5	27.49	341
BSP25CCE3-TBF	62030132	15	3	230/460	TEFC	38-35/17.5	27.49	341

T = totally enclosed

BF = bronze fitted

TB = totally enclosed bronze fitted

* Overall length of unit and amps is subject to the motor manufacture.

► Receiving inspection

Upon receiving the pump, it should be inspected for damage or shortages. If damage has occurred, file a claim immediately with the company that delivered the pump. If the manual is removed from the packaging, do not lose or misplace.

► Storage

Any product that is stored for a period longer than six (6) months from the date of purchase should be bench tested prior to installation. A bench test consists of, checking the impeller to assure it is free turning and a run test to assure the motor (and switch if provided) operate properly.

► Location

Locate pump as near as possible to the liquid being pumped. Do Not place pump more than 25 feet above the surface of the liquid supply. Be sure pump is level. Mount pump on a firmly so not to move due to vibration.

► Controls

Manual models require a separate approved pump control device or panel for automatic operation. Be sure the electrical specification of the control selected properly match the electrical specifications of the pump.

► Motor Connection

All wiring of motor and control, overload protection and grounding should be in accordance with the National Electrical Code, State and Local codes. Make motor connection per label located on motor or motor manufactures manual.

► Rotation

Pump rotation should agree with the direction on the rotation plate. If rotation on 3 phase is incorrect, interchange any two incoming wire leads. Rotation is "clockwise" when looking from the motor end.

► Suction



CAUTION! - Pump should not be operated without a suction strainer to prevent foreign matter from being drawn into impeller. The strainer should be cleaned regularly.

The use of pipe the same size as the port size is highly recommended. Using a smaller pipe line can cause internal damage. Make sure all lines are have air-tight joints. The smallest air leak in the suction line may prevent the pump from priming. All horizontal suction lines should slope up to the pump to avoid trapped air pockets.

► Discharge

Connect discharge hose or pipe to the discharge port. Make sure all lines are have air-tight joints.

► Priming

Remove pipe plug in top of body and fill the pump body completely with solids free liquid. In freezing weather prime pump with warm water.



DO NOT operate pump without priming first. Operating dry will damage seal.

► Starting

To start pump, apply power to motor per the Motor manufactures instructions.

► Shutdown

Disconnect electric power to shut down. It is recommended to drain and flush pump if pump has been operating in freezing weather.

► Service

Turn off and lock out power before servicing pump.

To replace, the *HINGE* section of gasket is at the *TOP* and the *LARGE* weight is on the pump side of gasket.

► Body, Volute & Impeller

Disconnect suction and discharge piping. Remove hex nuts and lockwashers then remove body from intermediate coupling.

Pull volute from intermediate. On BSP3CCE remove set screw on BSP4CCE & BSP5CCE remove hex nut, on BSP10CCE through BSP25CCE's remove capscrew, and unscrew the impeller from motor shaft in the right hand direction. Take note of the size and quantity of shims & used.

To reassemble, use the required number of shims and to result in an impeller-to-volute clearance of .015" max.

► Shaft Seal

Remove rotating member, spring and retaining ring of seal from shaft. Remove stationary by prying out with screwdriver. If any part shows wear or damage replace complete seal.



Handle all seal parts with care. Do Not damage lapped faces.

To reassemble, lightly oil ring and press stationary member over shaft and into intermediate coupling. Lightly oil motor shaft and inner surface of bellows of rotating member. With lapped surface facing intermediate coupling, slide rotating member onto shaft until lapped faces are of rotating member and stationary together.

► Motor

Remove capscrews and lockwashers to remove motor and slinger.

REASSEMBLE PUMP IN OPPOSITE ORDER.

► BSP3-4-5CCE

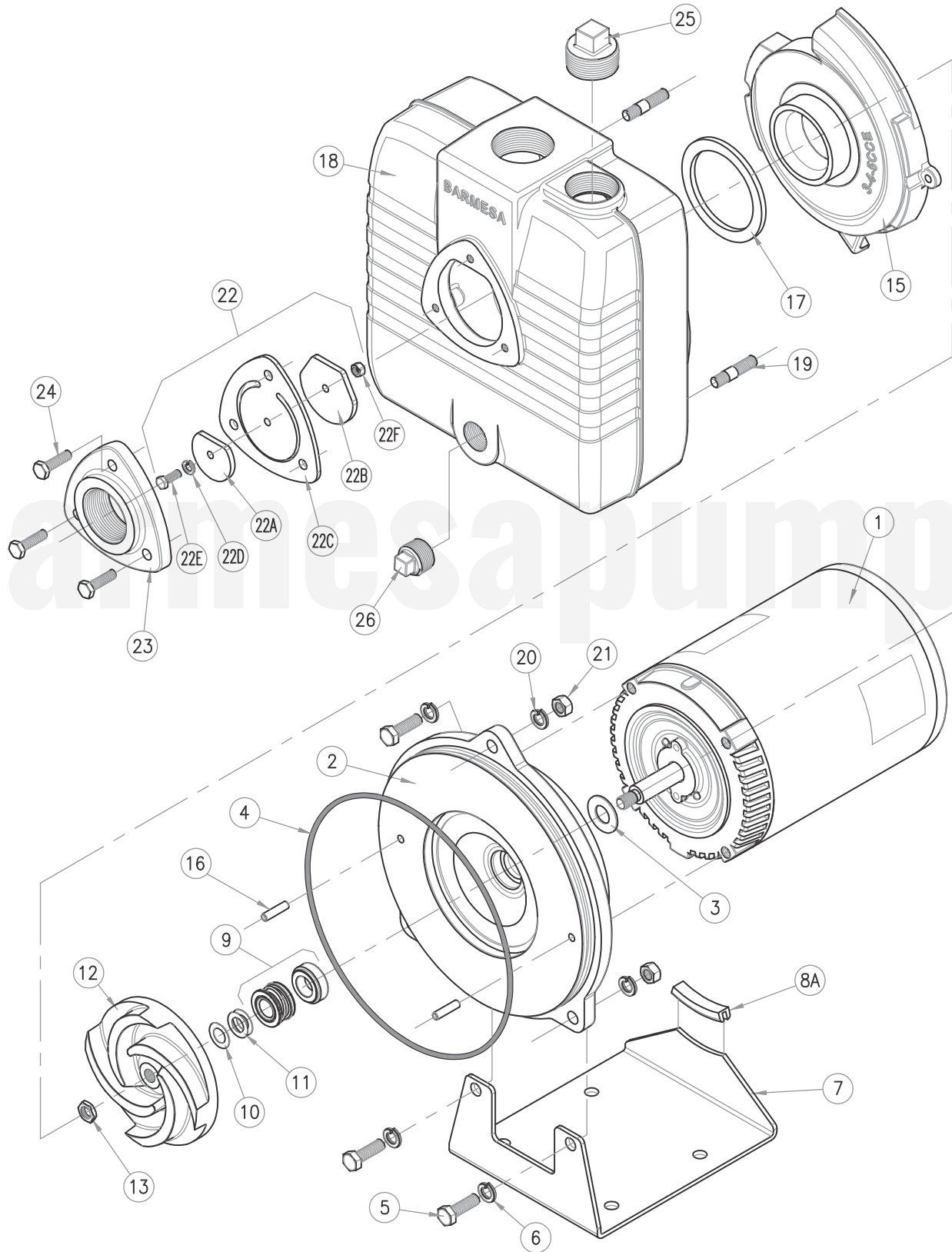

ITEM	QTY.	DESCRIPTION	PART No.
1	1	MOTOR MARATHON	
		BSP3CCE 1.5 HP, 1 PHASE, 3450 RPM	40010005
		BSP3CCE 1.5 HP, 3 PHASE, 3450 RPM	40010016
		BSP4CCE 2 HP, 1 PHASE, 3450 RPM	40010007
		BSP4CCE 2 HP, 3 PHASE, 3450 RPM	40010018
		BSP5CCE 3 HP, 1 PHASE, 3450 RPM	40010009
		BSP5CCE 3 HP, 3 PHASE, 3450 RPM	40010019
2	1	INTERMEDIATE COUPLING 3-4-5CCE	03010068
3	1	SLINGER Ø5/8" NEOPRENE	92010011
4	1	O-RING #2-269 BUNA-N	92010033
5	4	CAP SCREW 3/8" x 1¼"	91010413
6	4	LOCK WASHER 3/8"	91010012
7	1	BASE 3-4-5CCE THREE PHASE	30402001
		BASE 3-4-5CCE SINGLE PHASE	30402001B
8A	1	PAD BUNA-N	32010072
9	1	MECHANICAL SEAL Ø5/8"	31030135
10	2	SHIM 0.010" SS	91010143
11	3	SHIM 0.005" SS	91010142
12	1	IMPELLER 3CCE, CAST IRON	03140229
		IMPELLER 3CCE, BRONZE SAE 40	03140222
		IMPELLER 4CCE, CAST IRON	03140230
		IMPELLER 4CCE, BRONZE SAE 40	03140223
		IMPELLER 5CCE, CAST IRON	03140231
		IMPELLER 5CCE, BRONZE SAE 40	03140224
13	1	HEX. NUT 7/16-20UNF SS	91010434
15	1	VOLUTE 3-4-5CCE, CAST IRON	03120038
		VOLUTE 3-4-5CCE, BRONZE SAE 40	03120034
16	2	ROLL PIN #17715 Ø¼" x 1"	91010181
17	1	GASKET VOLUTE 3-4-5CCE, BUNA-N	92010091
18	1	BODY 3-4-5CCE CAST IRON	03090097B
19	3	STUD 3/8"-16 x 2"	91010374
20	3	LOCK WASHER 3/8"	91010012
21	3	HEX. NUT 3/8"	91010413
22		CHECK VALVE ASSEMBLY	
22A	1	WEIGHT Ø1.56"	03080001
22B	1	WEIGHT Ø2¼"	03080002
22C	1	GASKET 2"	92010229
22D	1	LOCK WASHER ¼"	91010011C
22E	1	ROUND HEAD SCREW ¼"-20 x 1" SS	--
22F	1	NUT ¼" SS	91010411
23	1	SUCTION FLANGE 1½"	03050020
24	3	CAP SCREW 5/16"-18UNC x 1"	91010222
25	1	PIPE PLUG 1¼" NPT CAST IRON	93010146
26	1	PIPE PLUG 3/4" CAST IRON	93010148

► BSP10CCE

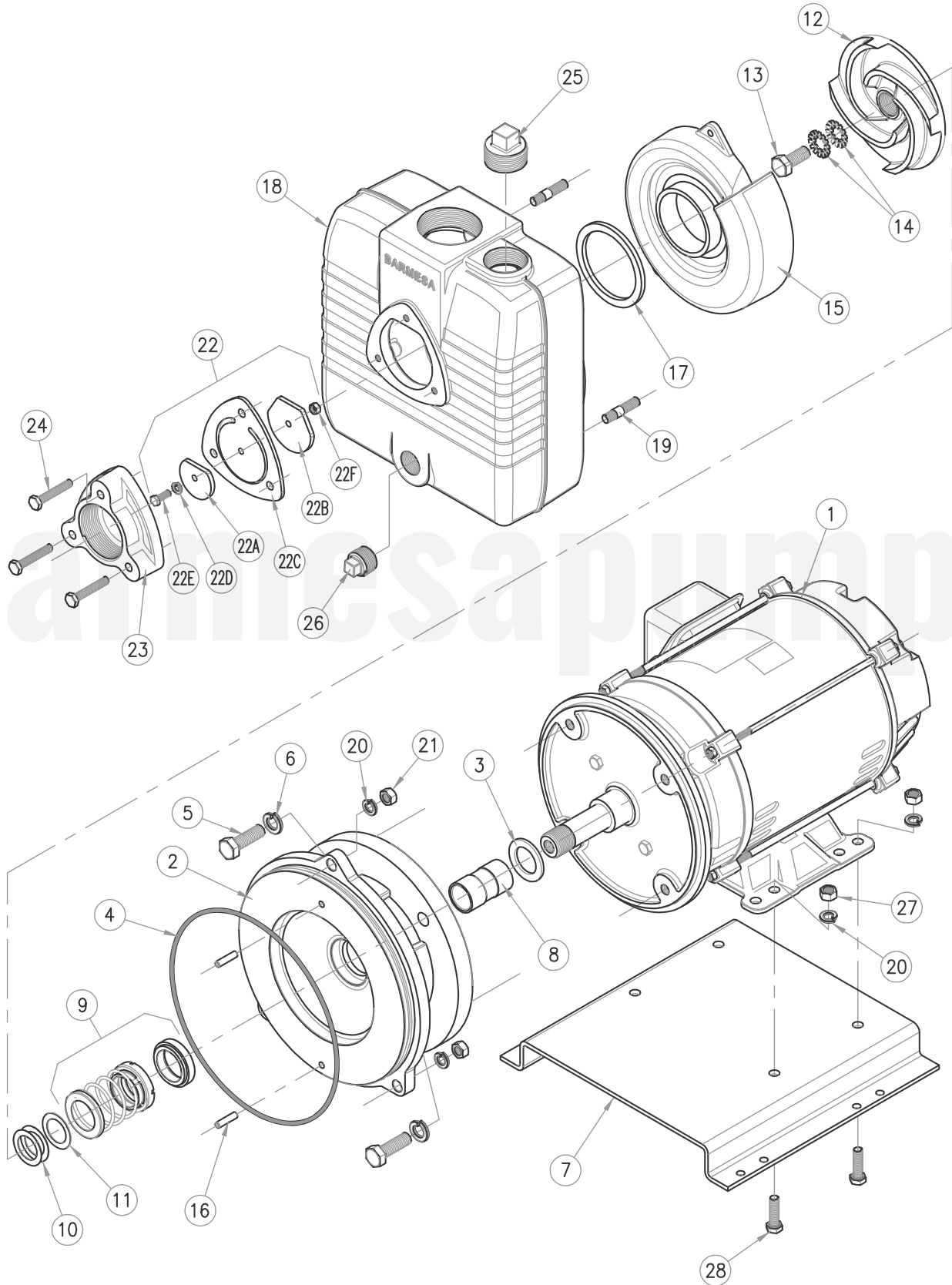

ITEM	QTY.	DESCRIPTION	PART No.
1	1	MOTOR US, 5 HP, 3 PHASE, 3450 RPM	40020211
2	1	INTERMEDIATE COUPLING 10CCE	03010069
3	1	SLINGER Ø1¼" NEOPRENE	92010014
4	1	O-RING #2-269 BUNA-N	92010033
5	4	HEX. SCREW 1/2" x 1½"	91010263
6	4	LOCK WASHER 1/2"	91010014
7	1	BASE 10CCE STEEL	30402002
8	1	SHAFT SLEEVE CCE BRONZE	30400839
9	1	MECHANICAL SEAL Ø1¼"	31030136
10	2	SHIM 0.010" SS	91010121
11	3	SHIM 0.031" SS	91010130
12	1	IMPELLER 10CCE, CAST IRON	03140232
		IMPELLER 10CCE, BRONZE SAE 40	03140225
13	1	HEX. HEAD SCREW 1/2" 20UNF x 1" SS	91010349B
14	2	SHAKEPROOF WASHER 1/2" SS	91010081
15	1	VOLUTE 10CCE, CAST IRON	03120039
		VOLUTE 10CCE, BRONZE SAE 40	03120035
16	2	ROLL PIN #17715 Ø¼" x 1"	91010181
17	1	GASKET VOLUTE 10CCE, BUNA-N	92010091B
18	1	BODY 10CCE CAST IRON	03090097
19	3	STUD 3/8"-16 x 2"	91010374
20	7	LOCK WASHER 3/8"	91010012
21	3	HEX. NUT 3/8"	91010413
22		CHECK VALVE ASSEMBLY	
22A	1	WEIGHT Ø1.56"	03080001
22B	1	WEIGHT Ø2¼"	03080002
22C	1	GASKET 2"	92010229
22D	1	LOCK WASHER ¼"	91010011C
22E	1	ROUND HEAD SCREW ¼"-20 x 1" SS	--
22F	1	NUT 1/4" SS	91010411
23	1	SUCTION FLANGE 2"	03050021
24	3	CAP SCREW 5/16"-18UNC x 2"	91010225
25	1	PIPE PLUG 1¼" NPT CAST IRON	93010146
26	1	PIPE PLUG 3/4" CAST IRON	93010148
27	4	HEX. NUT 3/8"	91010413
28	4	HEX. HEAD SCREW 3/8"-16 x 1¼"	91010243

► BSP15-20-25CCE

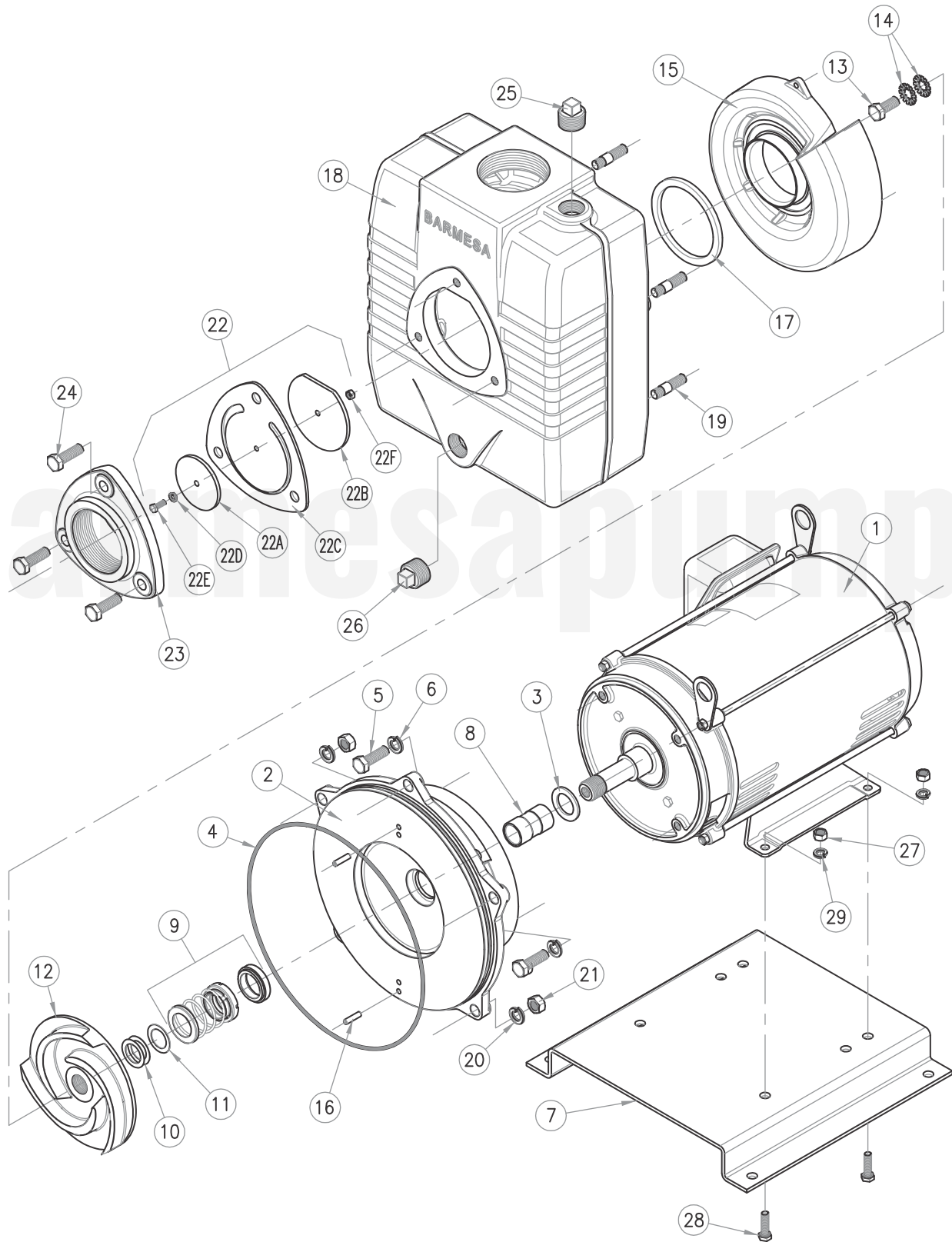

ITEM	QTY.	DESCRIPTION	PART No.
1	1	MOTOR US	
		BSP15CCE 7.5 HP, 3 PHASE, 3450 RPM	40020214
		BSP20CCE 10 HP, 3 PHASE, 3450 RPM	40020217
		BSP25CCE 15 HP, 3 PHASE, 3450 RPM	40020220
2	1	INTERMEDIATE COUPLING 15-20-25CCE	03010070
3	1	SLINGER Ø1¼" NEOPRENE	92010014
4	1	O-RING #2-276 BUNA-N	92010062
5	1	HEX. SCREW 1/2" x 1½"	91010263
6	1	LOCK WASHER 1/2"	91010014
7	1	BASE 15CCE	30402003
		BASE 20-25CCE	30402004
8	1	SHAFT SLEEVE BRONZE	30400839
9	1	MECHANICAL SEAL Ø1¼"	31030136
10	2	SHIM 0.010" SS	91010121
11	1	SHIM 0.031" SS	91010130
12	1	IMPELLER 15CCE, CAST IRON	03140233
		IMPELLER 15CCE, BRONZE SAE 40	03140226
		IMPELLER 20CCE, CAST IRON	03140234
		IMPELLER 20CCE, BRONZE SAE 40	03140227
		IMPELLER 25CCE, CAST IRON	03140235
		IMPELLER 25CCE, BRONZE SAE 40	03140228
13	1	HEX. HEAD SCREW 1/2" 20UNF x 1" SS	91010349B
14	2	SHAKEPROOF WASHER 1/2" SS	91010081
15	1	VOLUTE 15-20CCE, CAST IRON	03120040
		VOLUTE 15-20CCE, BRONZE	03120036
		VOLUTE 25CCE, CAST IRON	03120041
		VOLUTE 25CCE, BRONZE	03120037
16	2	ROLL PIN #17715 Ø¼" x 1"	91010181
17	1	GASKET VOLUTE 15-20-25CCE, BUNA-N	92010122
18	1	BODY 15-20-25CCE CAST IRON	03090098
19	5	STUD 1/2"-13 x 2"	91010310
20	5	LOCK WASHER 1/2"	91010014
21	5	HEX. NUT 1/2"	91010415
22		CHECK VALVE ASSEMBLY	
22A	1	WEIGHT Ø2.75"	03080007
22B	1	WEIGHT Ø4"	03080012
22C	1	GASKET 3"	92010217
22D	1	LOCK WASHER ¼"	91010011C
22E	1	ROUND HEAD SCREW ¼"-20 x 1" SS	91010342
22F	1	NUT ¼" SS	91010411
23	1	SUCTION FLANGE 1½"	03050022
24	3	HEX. CAP SCREW 1/2"-13UNC x 1½"	91010263
25	1	PIPE PLUG 1" NPT CAST IRON	93010141
26	1	PIPE PLUG 1" NPT CAST IRON	93010141
27	4	HEX. NUT 3/8"	91010413
28	4	HEX. HEAD SCREW 3/8"-16 x 1¼"	91010243



Risk of electric shock. Always disconnect the pump from the power source before handling inspections or repairs.

Symptom	Possible Cause(s)	Corrective Action
Little or no discharge and will not prime	<ol style="list-style-type: none"> 1. Pump body not filled with water 2. Total head too high 3. Suction head higher than pump designed for 4. Impeller partially or completely plugged 5. Leak in suction line 6. Foot-valve too small 7. Impeller damaged 8. Foot-valve or suction line not submerged deep enough in water, pulling air 9. Insufficient inlet pressure or suction head 10. Suction piping too small 11. Body gasket leaking 12. Suction or discharge line valves closed 13. Piping damaged 14. Clogged strainer or foot-valve 	<ol style="list-style-type: none"> 1. Fill pump body with water. 2. Shorten suction head 3. Lower suction head, install foot-valve and prime 4. Disassemble pump and clean out impeller 5. Repair or replace suction line 6. Match foot-valve size to piping or install one larger size foot-valve 7. Disassemble pump and replace impeller 8. Submerge lower in water 9. Increase inlet pressure by adding more water to tank or increasing back pressure by turning gate valve on discharge line partially closed. 10. Increase pipe size to pump inlet size or larger 11. Replace 12. Open 13. Clean or replace 14. Clean or replace
Loss of suction after satisfactory operation	<ol style="list-style-type: none"> 1. Air leak in suction line 2. When pump was last turned off, water siphoned out of pump body 3. Suction head higher than pump designed for 4. Insufficient inlet pressure or suction head 5. Clogged foot-valve, strainer or pump 6. Defective wearplate 	<ol style="list-style-type: none"> 1. Repair or replace suction line 2. Refill (reprime) pump body before restarting 3. Lower suction head, install foot-valve and prime 4. Increase inlet pressure by adding more water to tank or increasing back pressure by turning gate valve on discharge line to partially closed. 5. Unclog or replace 6. Replace
Pump overloads driver	<ol style="list-style-type: none"> 1. Total head lower than pump rating, unit delivering too much water 2. Specific gravity and viscosity of liquid being pumped different than the pump rating 	<ol style="list-style-type: none"> 1. Increase back pressure by turning gate valve on discharge line to partially closed position that will not overload motor. 2. Consult factory
Pump vibrates and/or makes excessive noise	<ol style="list-style-type: none"> 1. Mounting plate or foundation not rigid enough 2. Foreign material in pump causing unbalance 3. Impeller bent 4. Cavitation present 5. Piping not supported to relieve any strain on pump assembly 	<ol style="list-style-type: none"> 1. Reinforce 2. Disassemble pump and remove 3. Replace impeller 4. Check suction line for proper size and check valve in suction line if completely open, remove any sharp bends before pump and shorten suction line 5. Make necessary adjustments
Pump runs but no fluid	<ol style="list-style-type: none"> 1. Air leak in suction piping 2. Pump located too far from fluid source 3. Gate valve closed 4. Clogged strainer 5. Fouled foot-valve 6. Discharge height too great 7. Fouled impeller 8. Faulty mechanical seal 	<ol style="list-style-type: none"> 1. Replace 2. Replace 3. Open 4. Clean or Replace 5. Clean or Replace 6. Lower the height 7. Clean or Replace 8. Replace
Pump leaks at shaft	<ol style="list-style-type: none"> 1. Worn mechanical seal 2. Seal not installed properly 	<ol style="list-style-type: none"> 1. Replace 2. Follow service instructions for installing seal

NOTE: Barmesa Pumps assumes no responsibility for damage or injury due to disassembly in the field. Disassembly of the pumps or supplied accessories other than at Barmesa Pumps or its authorized service centers, automatically voids warranty.

BARMESA PUMPS FACTORY WARRANTY

Barmesa Pumps warrants that products of our manufacture will be free of defects in material and workmanship under normal use and service for 18 months from date of manufacture or 12 months from installation date whichever occurs first. This warranty gives you specific legal rights, which vary from state to state.

This warranty is a limited warranty, and no warranty related claims of any nature whatsoever shall be made against Barmesa Pumps, until the ultimate consumer or his/her successor notifies us in writing of the defect and delivers the product and/or defective part(s) freight prepaid to our factory or nearest authorized service station as instructed by Barmesa Pumps. THERE SHALL BE NO FURTHER LIABILITY, WHETHER BASED ON WARRANTY, NEGLIGENCE OR OTHERWISE. PRODUCT SHALL BE EITHER REPLACED OR REPAIRED AT THE ELECTION OF BARMESA PUMPS. Guarantees relating to performance specifications provided in addition to the foregoing material and workmanship warranties on a product manufactured by Barmesa Pumps, if any, are subject to possible factory testing. Any additional guarantees, in the nature of certified performance specifications or time frame must be in writing and such writing must be signed by our authorized factory manager at time of order placement and/or at time of quotation. Due to inaccuracies in field testing and should a conflict arises between the results of field testing conducted by or for the user, Barmesa Pumps reserves the right to have the product returned to our factory for additional testing.

This warranty shall not apply when damage is caused by (1) improper installation, (2) improper voltage, (3) lightning, (4) excessive sand or other abrasive material, (5) corrosion build-up due to excessive chemical content or (6) uncontrollable acts of god. Any modification of the original equipment will also void the warranty. We will not be responsible for loss, damage or labor cost due to interruption of service caused by defective pumps, parts or systems. Barmesa Pumps will not accept charges incurred by others without our prior written approval.

This warranty is void if our inspection reveals the product was used in a manner inconsistent with normal industry practice and/or our specific recommendations. The purchaser is responsible for communication of all necessary information regarding the application and use of the product. UNDER NO CIRCUMSTANCES WILL WE BE RESPONSIBLE FOR ANY OTHER DIRECT OR CONSEQUENTIAL DAMAGES, INCLUDING BUT NOT LIMITED TO TRAVEL EXPENSES, CONTRACTOR FEES, UNAUTHORIZED REPAIR SHOP EXPENSES, LOST PROFITS, LOST INCOME, LABOR CHARGES, DELAYS IN PRODUCTION, IDLE PRODUCTION, WHICH DAMAGES ARE CAUSED BY ANY DEFECTS IN MATERIAL AND/OR WORKMANSHIP AND/OR DAMAGE OR DELAYS IN SHIPMENT. THIS WARRANTY IS EXPRESSLY IN LIEU OF ANY OTHER EXPRESS OR IMPLIED WARRANTY. No rights extended under this warranty shall be assigned to any other person, whether by operation of law or otherwise, without our prior written approval.

IMPORTANT!

If you have a claim under the provision of the warranty, contact Barmesa Pumps or your authorized Barmesa Pumps Distributor:
warranty@barmesapumps.com
www.barmesapumps.com

