

HMV series



IMPORTANT! - Read all instructions in this manual before operating or servicing a pump.

Before installation, read the following instructions carefully. Failure to follow instruction and Safety information could cause serious bodily injury, death and/or property damage. Each Barmesa product is carefully inspected to insure proper performance. Closely following these instructions will eliminate potential operating problems, assuring years of trouble-free service.

⚠ DANGER "Danger" indicates an imminently hazardous situation which, if not avoided, WILL result in death or serious injury.

⚠ WARNING "Warning" indicates an imminently hazardous situation which, if not avoided, MAY result in death or serious injury.

⚠ CAUTION "Caution" indicates a potentially hazardous situation which, if not avoided, MAY result in minor or moderate injury.

IMPORTANT! - Barmesa Pumps is not responsible for losses, injury or death resulting from failure to observe these safety precautions, misuse, abuse or misapplication of pumps or equipment.



ALL RETURNED PRODUCTS MUST BE CLEANED, SANITIZED, OR DECONTAMINATED PRIOR TO SHIPMENT, TO INSURE EMPLOYEES WILL NOT BE EXPOSED TO HEALTH HAZARDS IN HANDLING SAID MATERIAL. ALL APPLICABLE LAWS AND REGULATIONS SHALL APPLY.

⚠ WARNING Installation, wiring, and junction connections must be in accordance with the National Electric Code and all applicable state and local codes. Requirements may vary depending on usage and location.

⚠ WARNING Installation and servicing is to be conducted by qualified personnel only.



Keep clear of suction and discharge openings. Do not insert fingers in pump with power connected; the rotating cutter and/or impeller can cause serious injury.



Always wear eye protection when working on pumps. Do not wear loose clothing that may become entangled in moving parts.



⚠ DANGER Pumps build up heat and pressure during operation. Allow time for pumps to cool before handling or servicing the pump or any accessory items associated with or near the pump.



⚠ DANGER This pump is not intended for use in swimming pools or water installations where human contact with pumped fluid.



⚠ DANGER Risk of electric shock. To reduce risk of electric shock, always disconnect pump from power source before handling any aspect of the pumping system. **Lock out power & tag.**

⚠ WARNING Do not exceed manufactures recommended maximum performance, as this could cause the motor to overheat.



⚠ DANGER Do not lift, carry or hang pump by the electrical cables. Damage to the electrical cables can cause shock, burns or death. **Never** handle connected power cords with wet hands. Use appropriate lifting device.

⚠ WARNING Ground Fault Circuit Interrupter (GFCI) to be used with plug-in type power cord.

⚠ WARNING Sump and sewage pumps often handle materials which could cause illness or disease. Wear adequate protective clothing when working on a used pump or piping. Never enter a basin after it has been used.



⚠ DANGER Failure to permanently ground the pump, motor and controls before connecting to power can cause shock, burns or death.



⚠ DANGER These pumps are not to be installed in locations classified as hazardous in accordance with the National Electric Code, ANSI/NFPA 70.

⚠ WARNING The Uniform Plumbing Code (UPC) states that sewage systems shall have an audio and visual alarm that signals a malfunction of the systems, that are required to reduce the potential for property damage.

IMPORTANT! - Prior to installation, record Model Number, MFG Date, Amps, Voltage, Phase and HP from pump name plate for the future reference. Also record the Voltage and Current Readings at Startup:

3 Phase Models	
Amps L1-2:	Volts L1-2:
Amps L2-3:	Volts L2-3:
Amps L3-1:	Volts L3-1:

Model Number: _____

MFG Date: _____

PHASE: _____ HP: _____

► Description

Our vertical multistage centrifugal pumps are driven by high efficiency electric motors. The motor output shaft directly connects with the pump shaft through a coupling. The pressure-resistant cylinder and flow passage components are fixed between pump head and inlet & outlet section with stay bolts. The inlet and outlet are located at the pump bottom at the same plane.

► Features

- › High efficient
- › Low noise
- › A little corrosive liquid resistance
- › Compact structure
- › Good appearance
- › Small volume
- › Light weight
- › Easy to service
- › Good seal performance
- › etc.

► Applications

- › Pumped liquids: low viscosity, neutral, non-explosive liquids, not containing solid particles or fibres. The liquid must not attack the pump materials chemically.
- › Boiler water supply and condensing system.
- › Water treatment, filtration system.
- › Food and beverage industries.
- › Pressure boosting in high-rise buildings.
- › Farmland irrigation, nursery irrigation and golf court irrigation.
- › Industry cleaning system.
- › Liquid conveying, circulation and boosting.
- › Hot and cool water.

► Operation conditions

- › Medium temperature: normal temperature type $-15\text{ °C} \sim +70\text{ °C}$
- › Hot water type $-15\text{ °C} \sim +105\text{ °C}$
- › Flow: $0.4 \sim 180\text{ m}^3/\text{h}$
- › Medium pH range: pH 5 - 9
- › Maximum ambient temperature: $+40\text{ °C}$
- › Maximum altitude: 1000 ft
- › Minimum inlet pressure: Refer to the catalog

⚠ CAUTION When pumping liquids with a density and/or viscosity higher than that of water, use motors with correspondingly higher outputs, if required.

► **Nomenclature**

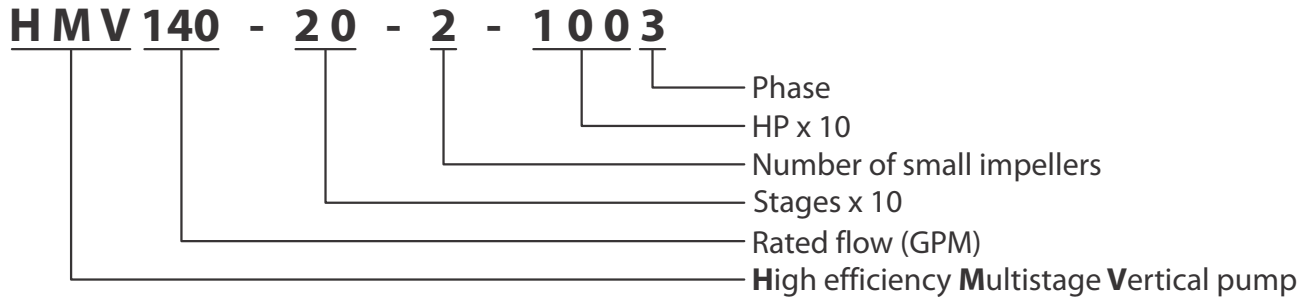

► **Nameplate**

To each pumping equipment is placed an identification plate, as shown below:

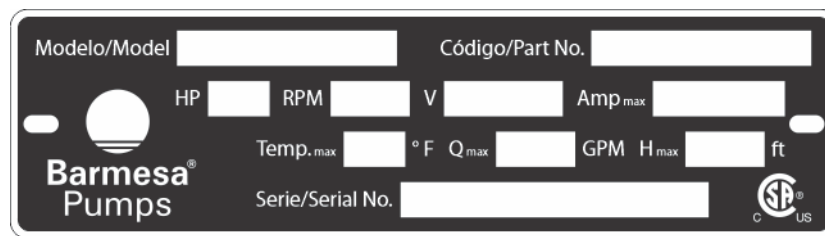

► **Structure**

- The pump is mainly composed of motor, pump head, diffuser, impeller, cylinder, inlet & outlet chamber, pump shaft, mechanical seal and so on.
- Key parts of the pump, diffuser, impeller, cylinder, shaft, are all made of stainless steel. Also the material of pump head and inlet & outlet chamber is made of stainless steel.
- Mechanical seal is a single face seal. Seal part is cemented carbides / carbon. Support part of support diffuser is made of tungsten carbide.

► HMV5, HMV14, HMV22

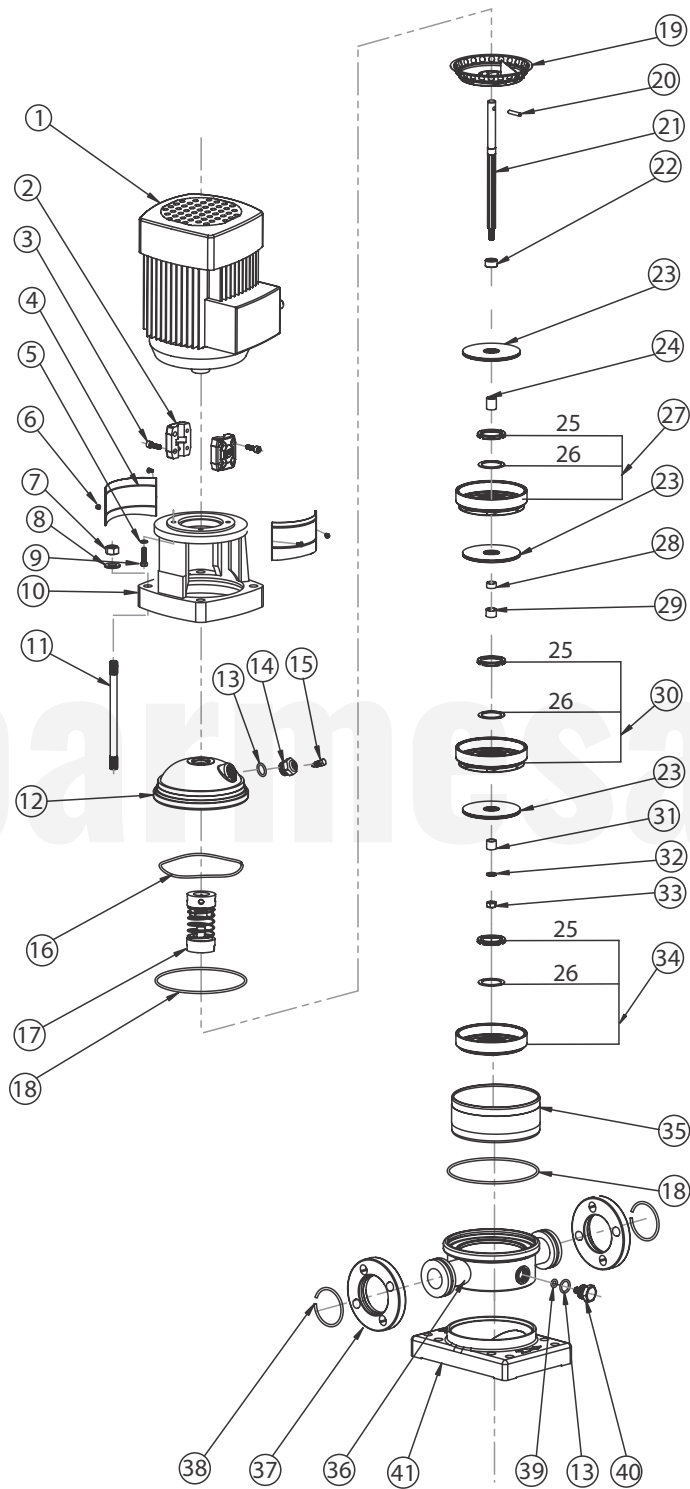

Item	Description
1	Motor
2	Coupling
3	Hex socket head screw
4	Coupling guard
5	Washer
6	Screw
7	Nut
8	Washer
9	Cap screw
10	Pump coupling
11	Stay bolt
12	Flange type base plate
13	O-ring 16 x 2.65
14	Air vent plug
15	Air vent screw
16	Corrugated spring
17	Mechanical seal
18	O-ring 136.5 x 3.3
19	Top diffuser
20	Shaft pin
21	Shaft
22	Location sleeve
23	Impeller
24	Impeller sleeve
25	Neck ring cover
26	Neck ring
27	Diffuser
28	Impeller short sleeve
29	Wear ring
30	Support diffuser
31	Inlet impeller cover
32	Washer
33	Nut
34	Inducer
35	Cylinder
36	Common inlet and outlet chamber
37	Flange
38	Flange retaining ring
39	O-ring 5.7 x 1.8
40	Draining plug
41	Base plate

For repair part please supply: model number and serial as shown on name plate, and part description and part number as shown on parts list.

► HMV45, HMV70, HMV95

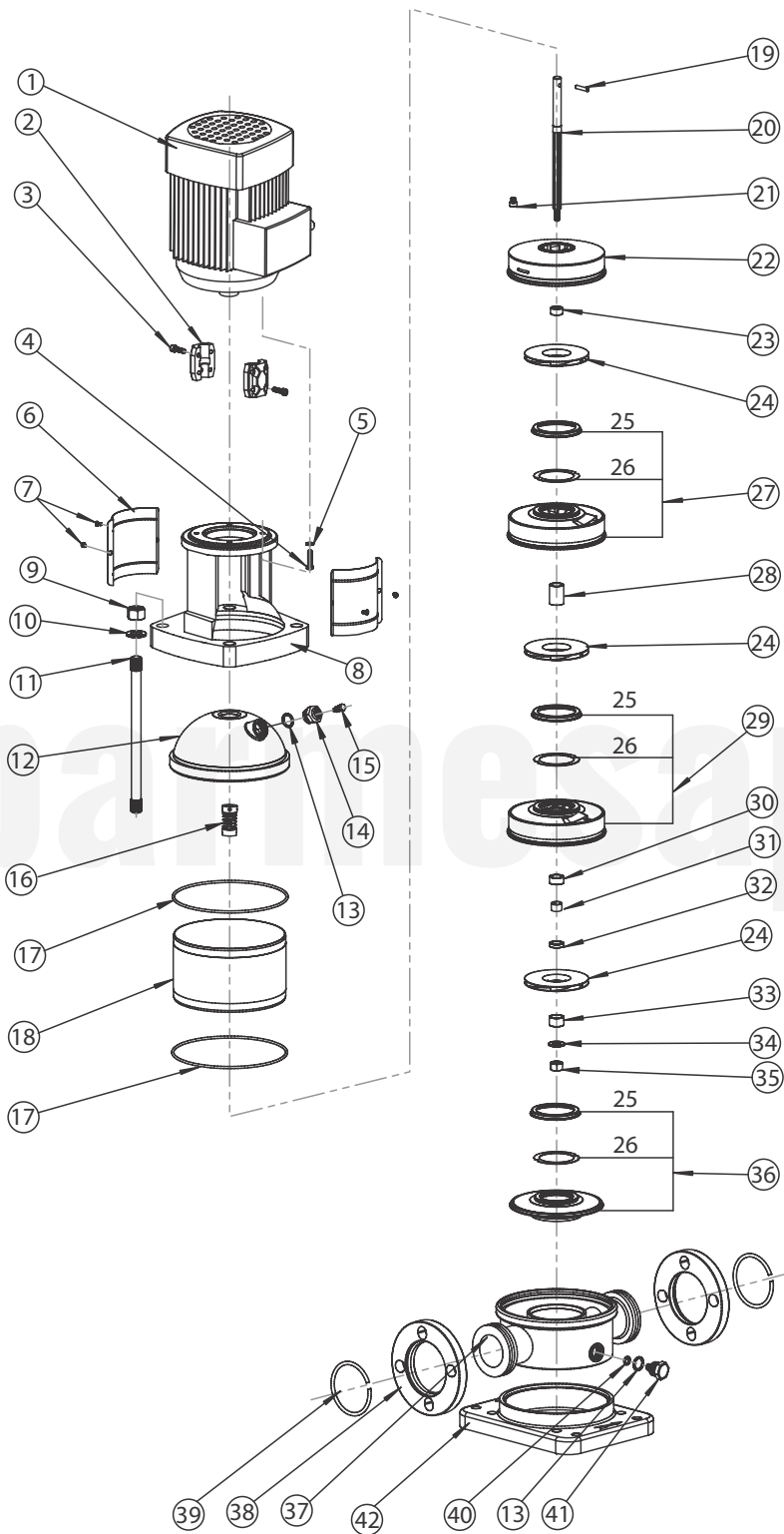

Item	Description
1	Motor
2	Coupling
3	Hex socket head screw
4	Cap screw
5	Washer
6	Coupling guard
7	Screw
8	Pump coupling
9	Nut
10	Washer
11	Stay bolt
12	Flange type base plate
13	O-ring 16 x 2.65
14	Air vent plug
15	Air vent screw
16	Mechanical seal
17	O-ring 169 x 3.3
18	Cylinder
19	Shaft pin
20	Shaft
21	Adjustment rubber
22	Top diffuser
23	Circlip cover
24	Impeller
25	Neck ring cover
26	Neck ring
27	Diffuser
28	Shaft sleeve
29	Support diffuser
30	Impeller sleeve
31	Wear ring
32	Impeller short sleeve
33	Inlet impeller cover
34	Gasket
35	Nut
36	Inducer
37	Common inlet and outlet chamber
38	Flange
39	Flange retaining ring
40	O-ring
41	Draining plug
42	Base plate

For repair part please supply: model number and serial as shown on name plate, and part description and part number as shown on parts list.

► HMV140, HMV200, HMV300

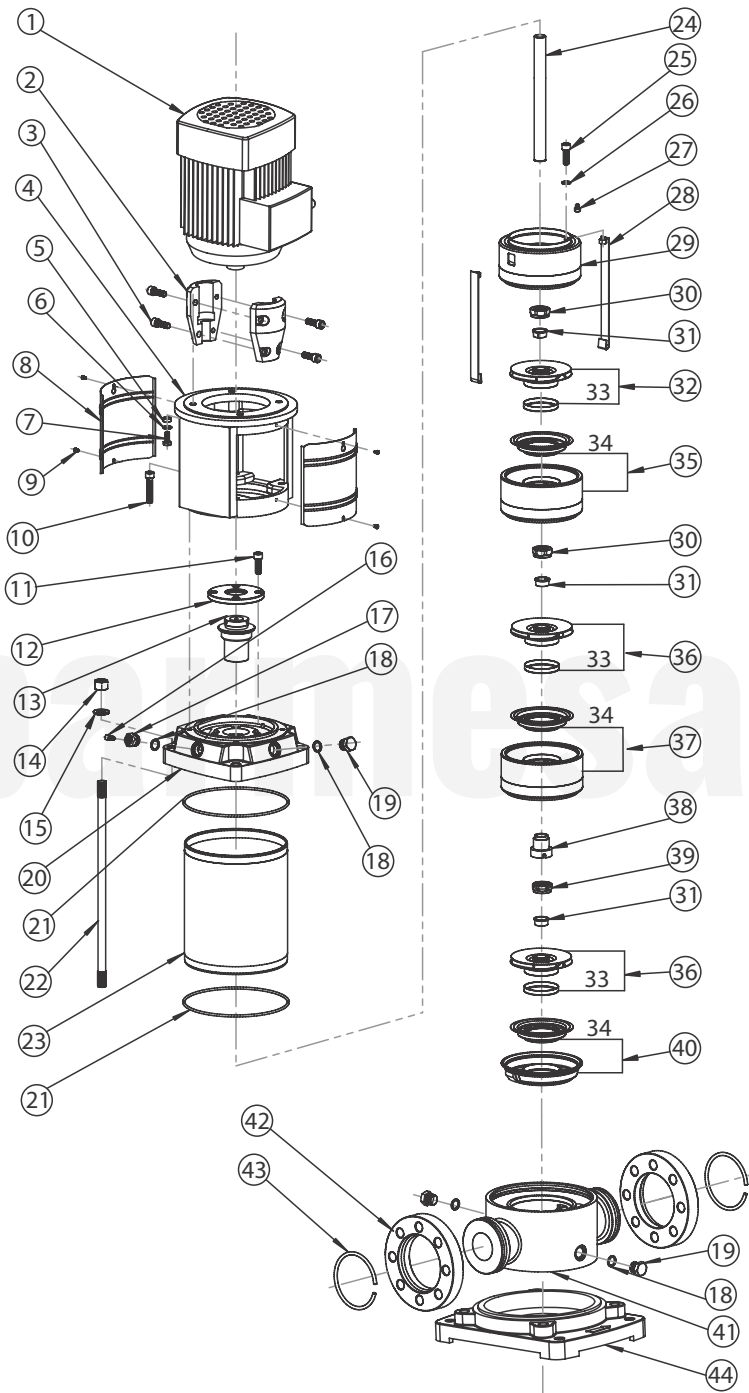

Item	Description
1	Motor
2	Coupling
3	Hex socket head screw
4	Motor coupling
5	Nut
6	Washer
7	Cap screw
8	Coupling guard
9	Screw
10	Hex socket head screw
11	Hex socket head screw
12	Cubierta del sello
13	Mechanical seal
14	Nut
15	Washer
16	Air vent screw
17	Air vent plug
18	O-ring
19	Draining plug
20	Pump coupling
21	O-ring
22	Stay bolt
23	Cylinder
24	Shaft
25	Hex socket head screw
26	Washer
27	Adjustment rubber
28	Straps
29	Top diffuser
30	Impeller nut
31	Cone
32	Impeller (small)
33	Impeller sleeve
34	Componentes del collar
35	Diffuser
36	Impeller
37	Support diffuser
38	Wear ring
39	Support nut
40	Inducer
41	Common inlet and outlet chamber
42	Flange
43	Retaining ring
44	Base plate

For repair part please supply: model number and serial as shown on name plate, and part description and part number as shown on parts list.

► Handling

- › When lifting the pump, use the motor eyebolts.

► Installation

- › The pump should be installed in a well ventilated and frost-free position. The distance between pump-motor and other objects should be at least 6 inches in order to have enough air to cool the motor.
- › The inlet pipe shall be as short as possible in order to reduce the head loss of the inlet.
- › Ensure that the check valve is installed in the pipe line system before the pump is installed. If pump is used for boiler water supply, a check valve must be installed in the piping between pump and boiler.
- › Pump shall be installed in a concrete base or other similar base with suitable height. It can also be installed in fixed grounds or fixed brackets on the wall.
- › Pay attention not to let the weight of pipe system on pump to prevent pump from damage.

⚠ CAUTION When installation, motor is not allowed to be hung upside down.

- › Arrow on the inlet and outlet chamber shows the direction of flow of liquid through the pump. Check whether the liquid can flow easily before starting pump.
- › Before pump installation, the inlet pipe line shall be cleaned. If there is impurities in the pipe, it is necessary to install a strainer at 20 - 40 inches in front of the pump inlet (particularly recommended for pump with flow less than 8 m³/h).
- › The air locks shall be avoided when installing the inlet pipe line. See figure 3.
- › If the outlet globe valve might be closed (or the flow is decreased to be zero), a bypass shall be installed in outlet pipeline to ensure adequate lubricating and cooling water to pass the pump.

Figure 2

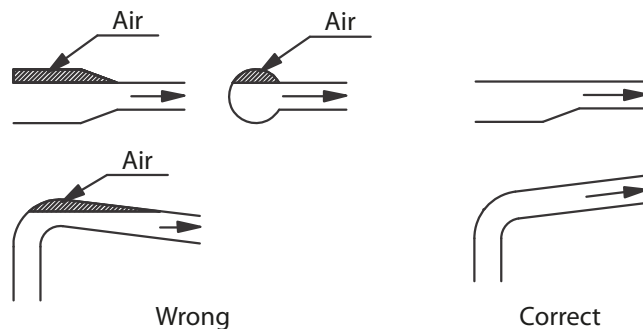
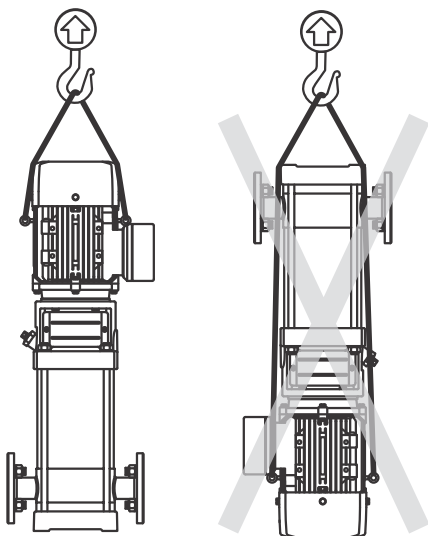

Figure 3

► **Electrical connection**

- › The electrical connections should be carried out by an authorized electrician.
- › To make sure the motor is suitable for the power supply, cables of the motor must be connected to power supply according to the figure on the terminal box and the motor nameplate.
- › Motor shall be connected with a fast and effective motor starter, to ensure that the motor will not be damaged by lack of phase, unstable voltage or overload. The motor shall be earthed reliably.

⚠ DANGER Before take apart the terminal box cover or dismantle pump, make sure that the power supply is switched off.

⚠ WARNING Electrical connection and safety devices

- › The pump units should be connected to the power supply by the appropriately rated power cables according to the motor ratings.
- › The pump units should always be equipped with safety devices as required in the standards (EN 809 and/or EN 60204-1) as well as by the national rules of the country where the pump is used.
- › Despite the rules of any country, the power supply to the pump unit must be equipped with at least following electrical safety devices with appropriate ratings:
 - ▾ Emergency switch.
 - ▾ Circuit breaker (as a supply disconnecting (isolating) device as well as an overcurrent protective device).
 - ▾ Motor overload protection.

⚠ DANGER Before opening the terminal box, please shut off the power supply to prevent an electric shock.



⚠ WARNING Before opening the coupling guards, stop pump first to prevent body injuries.



⚠ WARNING When installing the pump, please fix the foundation bolts to prevent pump from falling.



⚠ CAUTION Please fill grease to the pump when it required. For motor power is less than 7.5 HP, it is free of filling grease. For motor power is equal or bigger than 7.5 HP, please fill grease every 5000 running hours.



⚠ CAUTION Read the label on the cylinder carefully before start-up.

1. Do not start the pump until it has been filled with water or liquid fully.

- › Fill water in pump in inverse pouring system.
- › Close the pump outlet valve, release air vent screw on the pump head, and open the inlet valve slowly until stable water flows from the air vent s-screw. Then fasten the screw.
- › Open the check valve completely in the inlet pipeline. In open system, fill water in pump when liquid surface is lower than pump. (A check valve shall be installed in the inlet pipe).
- › Close the pump outlet valve, release air vent screw and fill the liquid in pump through the air vent screw hole until the pump and inlet pipe line are filled with water fully.
- › Fasten the air vent screw again.

⚠ CAUTION Do not start the pump until it has been filled with liquid fully and air vented. Be careful the direction of the air vent screw hole. Make sure the flowing water will not hurt persons or pump or its parts and especially, prevent from hurting for the hot water application.

2. Check the rotary direction.

- › Switch on the power supply and view the rotary direction by viewing the motor fan. Arrow on the pump head indicates the correct direction of rotation. That is, from the motor end, pump shall run counter-clockwise.

3. Check before pump start-up.

- › Check whether the foundation bolt is fasten.
- › Check whether pump is filled with water fully.
- › Check whether the voltage of power supply is correct.

- › Check whether it turns correctly.
- › Make sure that all pipe lines are connected tightly and can supply water normally.
- › The valves in the inlet pipe line are completely opened and the outlet valve shall be opened slowly after the pump is started up.
- › Check the operation pressure if pressure meter is installed.
- › Check all the controls for normal operation. If the pump is controlled by pressure switch, check and adjust the starting pressure and stopping pressure. Check the full load current to make sure it not surpasses the max. current.

4. Frequency of pump starts. Pump should not be started too frequently. It is suggested pump shall not be started more than 100 times per hour if the motor power is less or equal to 5 HP. When motor power is big than 5 HP, pump shall not be started more than 20 times in one hour. If pump starts and stops too frequently, control device shall be checked and adjusted to make pump not start and stop too frequently. Also, it is necessary to check the installation.

5. Suggestion: When pump running, flow should be controlled at the range of 0.5 - 1.3 times of rated flow.

6. Pump which is installed according to this installation manual will work effectively and require a little maintenance.

- › Mechanical seal will be adjusted automatically, the moving part and stationary part is lubricated and cooled by the transferring liquid. When replace the mechanical seal, the user don't need to disassemble the motor for power bigger than 10 HP.
- › The bearing in pump is lubricated by the transferring liquid.

7. Frost Protecting. Pump can be used in the system with anti-frozen measures to water. If the pump is installed in easily frozen place, suitable antifreeze shall be added to the transferring liquid to prevent pump from being damaged. If antifreeze is not used, pump shall be stopped when it is frozen. Pumps which are not being used should be drained.

8. The following should be checked regularly for pump.

- › Pump working and operating pressure.
- › Possible leakage.
- › Possible motor overheat.
- › Cleaning / replacement of all strainers.
- › The switch off time of motor when overload.
- › Frequency of starts and stops.
- › All control operation.

If malfunction is found, check system according to *"Fault Finding & Solution Chart"*.

9. Pump shall be cleaned and kept appropriately when it is not used for a long time.

10. Pump shall be prevented from being corrupted and damaged in storage.

1. For HMV5, HMV14, HMV22

- › Put the circlip cover on the shaft, and then fit the sleeve, impeller, impeller sleeve, diffuser, support diffuser. Continue the assemble order till the last impeller is fitted. Then fit the impeller cover, washer, screw the nut. Pay attention to the position of the support diffuser, for less stages pump, the last one is support diffuser. For more stages pump, support diffuser should be increased accordingly, the distance of each support diffuser should be even, and put on the support sleeve and bearing with support diffuser.
- › Put the inducer on the inlet & outlet chamber, and then fit the finished parts as above on the inducer.
- › Fit the O-ring on the inlet & outlet chamber, put on the cylinder and the top diffuser.
- › Put the pump head installed with O-ring, lining and corrugated spring on the cylinder. Screw the four nuts of the stay bolts on the base plate. Do not tighten one nut completely at one time, but tighten them symmetrically in turn.
- › Fit the mechanical seal and tighten it, then install motor and coupling, screw the bolts in coupling (but not tightly), press the coupling and shaft down to the direction of the base plate. Then lift it about 0.04" in reverse direction, tighten the screws. Note that the space between the two couplings should be equal.
- › Tighten fixing bolts in mechanical seal, rotate the coupling to ensure that the shaft can rotate freely and not be choked.
- › Reverse the process above can disassemble a pump.

2. For HMV10, HMV15, HMV20

- › Put the circlip cover on the shaft, and then fit the sleeve, impeller, impeller sleeve, diffuser, support diffuser, bearing, support sleeve. Continue the assemble order till the last impeller is fitted, and then install the impeller cover, washer, tighten the nuts.
- › Put the inlet & outlet chamber on the base plate, then put the O-ring, clamp plate inducer on inlet & outlet chamber, then put the finished parts on the inducer, and put the top diffuser on the top, tighten nuts of straps. At last, put on the cylinder.
- › Put the pump head installed with O-ring, lining and adjusting rubber on the cylinder, then tighten the four stay bolts symmetrically in turn.
- › Fit the mechanical seal and tighten it, then install motor and coupling, screw the bolts in coupling (but not tightly), press the coupling and shaft down to the direction of the base plate. Then lift it about 0.04" in reverse direction, tighten the screws. Note that the space between the two couplings should be equal.
- › Tighten fixing bolts in mechanical seal, rotate the coupling to ensure that the shaft can rotate freely and not be choked.
- › Reverse the process above can disassemble a pump.

3. For HMV32, HMV45, HMV64

- › Put the inlet & outlet chamber on the base plate, fit flanges on inlet & outlet chamber at two sides, and fit the inducer.
- › Put the first impeller on the shaft, tighten the nuts and put the impeller on the neck ring base of inducer, then put on the diffuser impeller, support diffuser, until the top diffuser, then fix all the diffuser with the straps.
- › Shaft parts: fit the bottom sleeve, cover, washer on the shaft, tighten the bolts, fit bottom bearing on the inlet & outlet chamber, fit washer. Then put the shaft parts on the inlet & outlet chamber, fit on O-ring, lubricate the O-ring and then put on the cylinder.
- › Fit stay bolts on the base plate, then fit the O-ring, adjusting rubber, air vent gag on the pump head, and put the pump head on the stay bolts, then put on the washer and tighten all the nuts.
- › Fit the mechanical seal on the pump head, then fit the seal cover, tighten the bolts, and the bolts in the seal. Lift the shaft and insert the adjusting slice.
- › Fit the bracket and motor on the pump head.
- › Finally fit the coupling, tighten the bolts, and take out the adjusting slice. Rotate the coupling to ensure that the shaft can rotate freely and not be choked.
- › Reverse the above process to disassemble a pump.

4. For HMV100, HMV130, HMV160

- › Put the inlet & outlet chamber on the base plate, fit flanges on inlet & outlet chamber at two sides, and fit the inducer.
- › Fit washer, shaft sleeve, inlet impeller sleeve, cover, washer and fasten the nut.
- › Fit impeller shaft sleeve, impeller, and fasten impeller nut.
- › Put the shaft parts on the inducer, fit support diffuser, impeller sleeve, impeller, fasten impeller nut, then fit diffuser, impeller, et cetera until the last diffuser.
- › Fit the top diffuser, use straps to fasten all diffuser. Fit O-ring on the inlet and outlet chamber, lubricate them and put on cylinder.
- › Fit stay bolts on the base plate, fit O-ring on the pump head, adjusting rubber, air vent screw, et cetera. Then put the pump head on the stay bolts, fit washer, fasten nut.
- › Fit the mechanical seal on the pump head, then fit the seal cover, tighten the bolts, and the bolts in the seal. Lift the shaft and insert the adjusting slice.
- › Fit the bracket and motor on the pump head.
- › Finally fit the coupling, tighten the bolts, and take out the adjusting slice. Rotate the coupling to ensure that the shaft can rotate freely and not be choked.
- › Reverse the above process to disassemble a pump.

Caution: Before removing the terminal box cover and before any removal/dismantling of the pump, make sure that the power supply has been switched off.

FAULT	CAUSE	SOLUTION	REMARKS
Motor does not run when started.	a) Power supply failure.	a) Check power supply.	
	b) Fuses are blown.	b) Replace fuses.	
	c) Motor is over loaded.	c) Check system.	
	d) Main contacts of starter are not connected well or the coil is defective.	d) Replace motor starter.	
	e) Control circuit is defective.	e) Check control circuit.	
	f) Motor is defective.	f) Repair.	
Overload device of motor starter trips out immediately when power supply is switched on.	a) Fuses are blown.	a) Replace fuses.	In the case of d) and e), users shall not disassemble the pump by themselves.
	b) Contacts of overload device are faulty.	b) Check motor starter.	
	c) Cable connection is loose or faulty.	c) Check cables and power supply.	
	d) Motor winding is defective.	d) Replace motor.	
	e) Pump mechanically blocked.	e) Check and repair pump.	
Overload device trips out occasionally.	a) The setting of overboard is too low.	a) Reset overload setting.	
	b) Periodic power supply faults.	b) Check power supply.	
	c) Low voltage at peak times.	c) Add regulator.	
Motor starter has not tripped out but the pump does not run.	a) Contacts of starter are not contacted well or the coil is faulty.	a) Change motor starter.	
	b) Control circuit are defective	b) Check control circuit.	
Pumped water does not flow constantly.	a) Suction pipe is too small.	a) Enlarge inlet pipe line.	
	b) There is not sufficient water in pump water inlet.	b) Improve system and increase coming water.	
	c) Liquid level is low.	c) Try to lift liquid level.	
	d) Pump inlet pressure is too low compared with water temperature, pipe line loss and flow.	d) Improve system and try to increase the inlet pressure.	
	e) Suction pipe is partly blocked by impurities.	e) Check and clear impurities.	
Pump runs but gives no water.	a) Suction pipe is blocked by impurities.	a) Check and clean suction pipe.	
	b) Foot valve or check valve is closed.	b) Check and repair foot valve or check valve.	
	c) Leakage in suction pipe.	c) Check and repair suction pipe.	
	d) There is air in suction pipe or pump.	d) Refill liquid, release air.	
Pump runs back wards when switched off.	a) Leakage in suction pipe.	a) Check suction pipe.	
	b) Foot valve or check valve is defective.	b) Check and repair foot valve or check valve.	
	c) Foot valve is blocked in opened or partly opened position.	c) Check and repair foot valve.	
	d) There is air in suction pipe.	d) Check and repair suction.	
Abnormal vibration or noise from pump	a) Leakage in suction pipe.	a) Check and repair suction pipe.	In the case of e), users shall not disassemble the pump by themselves.
	b) Suction pipe is too small or suction pipe is partly blocked by impurities.	b) Enlarge or check suction pipe.	
	c) There is air in suction pipe or pump.	c) Refill liquid to the pump and vent air.	
	d) The comparison of the delivery head of device with delivery head of pump is very low.	d) Improve system or choose another pump model.	
	e) Pump mechanically blocked.	e) Check and repair pump.	

BARMESA PUMPS FACTORY WARRANTY

Barmesa Pumps warrants that products of our manufacture will be free of defects in material and workmanship under normal use and service for 18 months from date of manufacture or 12 months from installation date whichever occurs first. This warranty gives you specific legal rights, which vary from state to state.

This warranty is a limited warranty, and no warranty related claims of any nature whatsoever shall be made against Barmesa Pumps, until the ultimate consumer or his/her successor notifies us in writing of the defect and delivers the product and/or defective part(s) freight prepaid to our factory or nearest authorized service station as instructed by Barmesa Pumps. THERE SHALL BE NO FURTHER LIABILITY, WHETHER BASED ON WARRANTY, NEGLIGENCE OR OTHERWISE. PRODUCT SHALL BE EITHER REPLACED OR REPAIRED AT THE ELECTION OF BARMESA PUMPS. Guarantees relating to performance specifications provided in addition to the foregoing material and workmanship warranties on a product manufactured by Barmesa Pumps, if any, are subject to possible factory testing. Any additional guarantees, in the nature of certified performance specifications or time frame must be in writing and such writing must be signed by our authorized factory manager at time of order placement and/or at time of quotation. Due to inaccuracies in field testing and should a conflict arises between the results of field testing conducted by or for the user, Barmesa Pumps reserves the right to have the product returned to our factory for additional testing.

This warranty shall not apply when damage is caused by (1) improper installation, (2) improper voltage, (3) lightning, (4) excessive sand or other abrasive material, (5) corrosion build-up due to excessive chemical content or (6) uncontrollable acts of god. Any modification of the original equipment will also void the warranty. We will not be responsible for loss, damage or labor cost due to interruption of service caused by defective pumps, parts or systems. Barmesa Pumps will not accept charges incurred by others without our prior written approval.

This warranty is void if our inspection reveals the product was used in a manner inconsistent with normal industry practice and/or our specific recommendations. The purchaser is responsible for communication of all necessary information regarding the application and use of the product. UNDER NO CIRCUMSTANCES WILL WE BE RESPONSIBLE FOR ANY OTHER DIRECT OR CONSEQUENTIAL DAMAGES, INCLUDING BUT NOT LIMITED TO TRAVEL EXPENSES, CONTRACTOR FEES, UNAUTHORIZED REPAIR SHOP EXPENSES, LOST PROFITS, LOST INCOME, LABOR CHARGES, DELAYS IN PRODUCTION, IDLE PRODUCTION, WHICH DAMAGES ARE CAUSED BY ANY DEFECTS IN MATERIAL AND/OR WORKMANSHIP AND/OR DAMAGE OR DELAYS IN SHIPMENT. THIS WARRANTY IS EXPRESSLY IN LIEU OF ANY OTHER EXPRESS OR IMPLIED WARRANTY. No rights extended under this warranty shall be assigned to any other person, whether by operation of law or otherwise, without our prior written approval.

IMPORTANT!

If you have a claim under the provision of the warranty, contact Barmesa Pumps or your authorized Barmesa Pumps Distributor:
warranty@barmesapumps.com
www.barmesapumps.com

