

IA series

2-125 HP @ 1750 y 3500 RPM



* Representative image



IMPORTANT! - Read all instructions in this manual before operating or servicing a pump.

Before installation, read the following instructions carefully. Failure to follow instruction and safety information could cause serious bodily injury, death and/or property damage. Each Barmesa product is carefully inspected to insure proper performance. Closely following these instructions will eliminate potential operating problems, assuring years of trouble-free service.

⚠ DANGER Indicates an imminently hazardous situation which, if not avoided, WILL result in death or serious injury.

⚠ WARNING Indicates an imminently hazardous situation which, if not avoided, MAY result in death or serious injury.

⚠ CAUTION Indicates a potentially hazardous situation which, if not avoided, MAY result in minor or moderate injury.

IMPORTANT! - Barmesa Pumps is not responsible for losses, injury or death resulting from failure to observe these safety precautions, misuse, abuse or misapplication of pumps or equipment.

ALL RETURNED PRODUCTS MUST BE CLEANED, SANITIZED, OR DECONTAMINATED PRIOR TO SHIPMENT, TO INSURE EMPLOYEES WILL NOT BE EXPOSED TO HEALTH HAZARDS IN HANDLING SAID MATERIAL. ALL APPLICABLE LAWS AND REGULATIONS SHALL APPLY.

⚠ WARNING Installation, wiring, and junction connections must be in accordance with the National Electric Code and all applicable state and local codes. Requirements may vary depending on usage and location.

⚠ WARNING Installation and servicing is to be conducted by qualified personnel only.

 Keep clear of suction and discharge openings. Do not insert fingers in pump with power connected; the impeller can cause serious injury.

 Always wear eye protection when working on pumps. Do not wear loose clothing that may become entangled in moving parts.

⚠ DANGER Pumps build up heat and pressure during operation. Allow time for pumps to cool before handling or servicing the pump or any accessory items associated with or near the pump. Do not block or restrict the discharge pipe/hose.

⚠ WARNING Do not pump hazardous materials (flammable, caustic, etc.) or use these pumps in water over 160 °F. Do not exceed manufacturers recommended maximum performance, as this could cause the motor to overheat.

⚠ DANGER This pump is not intended for use in swimming pools or water installations where there is human contact with pumped fluid.

⚠ DANGER Risk of electric shock. To reduce risk of electric shock, always disconnect pump from power source before handling any aspect of the pumping system. **Lock out power and tag.**

⚠ DANGER Do not lift, carry or hang pump by the electrical cables. Damage to the electrical cables can cause shock, burns or death. **Never** handle connected power cords with wet hands. Use appropriate lifting device.

⚠ DANGER Failure to permanently ground the pump, motor and controls before connecting to power can cause shock, burns or death.

⚠ WARNING If engine driven, never operate in an enclosed building or area where exhaust gases can accumulate, or near a building where gases can seep inside; always take provisions for adequate ventilation.

⚠ WARNING Do not breathe exhaust fumes when working in the area of the engine. (Exhaust gases are odorless and deadly poison.)

⚠ WARNING Never add fuel to the tank while the engine is running. Stop engine and allow to cool. **Do not** smoke while refueling the engine. **Do not** refuel near open flame.

⚠ WARNING Carefully read instruction manuals supplied with motor or engine before operating or servicing.

IMPORTANT! - Prior to installation, record Model Number, Serial, Amps, Voltage, Phase and HP from pump name plate for the future reference. Also record the Voltage and Current Readings at Startup:

1 Phase Models	
Amps:	Volts:
3 Phase Models	
Amps L1-2:	Volts L1-2:
Amps L2-3:	Volts L2-3:
Amps L3-1:	Volts L3-1:

Model Number: _____

Serial: _____

Phase: _____ HP: _____

SUCTION:	1½" - 8" NPT or flange horizontal
DISCHARGE:	1" - 6" NPT or flange vertical
LIQUID TEMPERATURE:	160°F (71 °C) max.
VOLUTE:	Cast iron ASTM A-48 class 30
INTERMEDIATE COUPLING:	Cast iron ASTM A-48 class 30
IMPELLER:	Cast iron ASTM A-48 class 30 or stainless steel 304. Investment casting, dynamically balanced.
SEAL:	Mechanical, type 01. Ceramic stationary part, carbon ring seal and exclusion in the rotating part. Buna-N elastomer and stainless steel spring.
SHAFT SLEEVE:	Stainless steel
O-RINGS:	Buna-N
MOTOR:	High quality premium efficiency TEFC electric motors, 1 & 3 phases, 60 Hz, NEMA, with rated output from 2 up to 125 HP, 1750 & 3500 RPM and frame sizes from 182 JM to 405 JM.
HARDWARE:	Carbon steel
PAINT:	Air dry enamel, water based.

barmesapumps

► Receiving inspection

Upon receiving the pump, it should be inspected for damage or shortages. If damage has occurred, file a claim immediately with the company that delivered the pump. If the manual is removed from the packaging, do not lose or misplace.

► Storage

Any product that is stored for a period longer than six (6) months from the date of purchase should be bench tested prior to installation. A bench test consists of, checking the impeller to assure it is free turning and a run test to assure the motor (and switch if provided) operate properly.

At any time exceeding six (6) months, but no more than twenty four (24), the equipment must be stored in a controlled area, keeping it away from contact with rain, dust, etc., and the temperature is maintained between 43-104 °F. If there is a possibility of high humidity (coastlines, etc.), the entire unit must be sprayed with antioxidant liquid.

► Service Stations

To find the nearest Barmesa Pumps authorized service shop, please directly contact your distributor or the factory.

► Installation

The pump should be as close as possible to the liquid to be pumped, with a minimum number of couplings, adapters, etc., in order to reduce friction on the suction side.

The suction and discharge piping must be perfectly aligned in the pump volute and supported independently using support or anchors, this to prevent excessive load on the volute.

The anchors of the motor are to be anchor, on a raised base, approximately 4", this to prevent accumulated water from entering the motor.

***See friction table in pipes and fittings to determine the dimensions of the suction and discharge. (Page 8)*

► Suction

Use pipe or hose reinforced sufficiently robust to prevent collapsing by the difference in atmospheric pressure. Check for leaks at all joints.

A successful operation depends on the calculation of the friction loss in the suction, considering acceptable limits. The minimum suction pipe size to use can be determined by comparing the NPSH available at the pump suction against the NPSH required by the impeller, as shown in the performance curves.

Usually, we recommend using a pipe diameter of 1/2" to 1" greater as that of the suction volute or body.

A strainer or sieve should be installed in the suction to prevent the entry of objects. The strainer must have a free entry area at least three times the pipe diameter. Usually a suction valve is combined with a strainer *Figure 1*.

Figure 1 Proper installation.

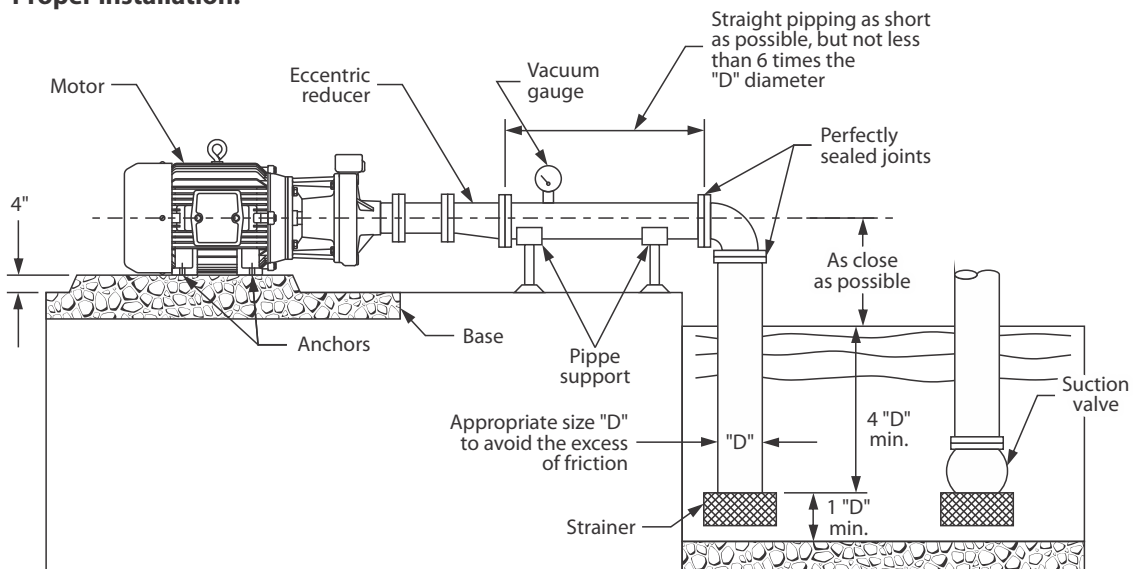

Table 1 Friction in meters x 100 m of piping.

LITERS PER MINUTE	PIPING DIAMETER											GALLONS PER MINUTE
	1"	1¼"	1½"	2"	2½"	3"	4"	5"	6"	8"	10"	
30	4.54											8
37	6.86	1.77										10
45	9.62	2.48										12
57	16.2	4	1.53									15
68	20.6	5.22	2.42									18
76	25.1	6.34	2.94									20
95	38.7	9.6	4.48	1.2	0.54							25
113	54.6	13.6	6.26	1.82	0.75							30
151	95	23.5	10.79	3.1	1.28							40
170	119	29.4	13.45	3.85	1.6							45
189	146	36	16.4	4.67	1.94	0.66						50
208		43.2	19.7	5.51	2.33	0.79						55
227		51	23.2	6.59	2.72	0.92						60
246		59.6	27.1	7.7	3.17	1.07						65
265		68.8	31.3	8.86	3.63	1.22						70
284		78.7	35.8	10.15	4.14	1.39						75
303		89.2	40.5	11.4	4.66	1.57						80
322		100	45.6	12.6	5.27	1.77						85
360		125	56.5	15.8	6.49	2.18	0.57					95
378		138	62.2	17.4	7.11	2.39	0.62					100
416			75.25	21.05	8.55	2.88	0.75					110
454			88.3	24.7	10	3.37	0.88					120
530			119	33.2	13.5	4.51	1.17	0.38				140
568			137.5	38.1	15.45	5.16	1.33	0.43				150
605			156	43	17.4	5.81	1.49	0.48				160
643				48.55	19.65	6.54	1.67	0.54				170
681				54.1	21.9	7.28	1.86	0.6				180
757				66.3	26.7	8.9	2.27	0.73	0.3			200
833				80	32.2	10.07	2.72	0.87	0.35			220
908				95	38.1	12.6	3.21	1.03	0.41			240
984				111	44.5	14.7	3.74	1.2	0.48			260
1060				128	51.3	16.9	4.3	1.38	0.56			280
1135				146	58.5	19.2	4.89	1.58	0.63			300
1324					79.2	26.1	6.55	2.11	0.85			350
1514					103	33.9	8.47	2.72	1.09	0.27		400
1892						52.5	13	4.16	1.66	0.42		500
2082						63.2	15.7	4.94	2	0.5		550
2271						74.8	18.6	5.88	2.34	0.59	0.19	600
2649						101	25	7.93	3.13	0.79	0.25	700
2838							28.7	9.07	3.59	0.91	0.29	750
3028							32.4	10.22	4.04	1.02	0.32	800
3217							36.6	11.56	4.5	1.13	0.36	850
3406							40.8	12.9	5.05	1.27	0.41	900
3595							45.5	14.35	5.61	1.42	0.45	950
3785							50.2	15.8	6.17	1.56	0.5	1000
4163								19.15	7.41	1.87	0.6	1100
4542								22.5	8.76	2.2	0.7	1200
4920								26.45	10.2	2.56	0.81	1300

NOTE: The values in this table refer to frictions and clean water pipes and hoses smooth walls. As used pipe and / or hose rough walls increase the values about 50% to 100%.

Table 1 Equivalent length in meters of straight pipe and valve connections for calculating friction.











PART	DESCRIPTION	DIAMETER									
		1"	1¼"	1½"	2"	2½"	3"	4"	5"	6"	
	STANDARD 90° ELBOW	0.84	1.07	1.22	1.68	1.98	2.44	3.35	4.12	4.88	
	MEDIUM RADIUS ELBOW 90°	0.69	0.92	1.07	1.37	1.68	2.14	2.75	3.51	4.27	
	LONG RADIUS ELBOW 90°	0.54	0.69	0.84	1.07	1.37	1.6	2.14	2.75	3.36	
	STANDARD 45° ELBOW	0.38	0.54	0.61	0.77	0.92	1.15	1.53	1.83	2.29	
	STANDARD TEE	1.68	2.29	2.75	3.36	4.28	5.19	6.71	8.23	10.1	
	ANGLE GLOBE VALVE (OPEN)	3.97	5.49	6.71	8.23	10.7	12.2	16.8	21.3	25.9	
	GLOBE VALVE (OPEN)	7.93	10.7	13	16.8	21.3	24.4	35.1	42.7	48.8	
	GATE VALVE (OPEN)	0.19	0.25	0.29	0.38	0.43	0.54	0.69	0.84	1.07	
	INCREASER	1.21	1.52	1.82	2.74	3.35	4.26	6.09	7.92	10.1	
	REDUCER	0.3	0.3	0.3	0.61	0.61	0.9	1.21	1.21	2.13	
	SUCTION VALVE	0.91	1.21	1.52	2.13	2.74	3.35	4.87	6.4	7.92	

Figure 2 Wrong installation.

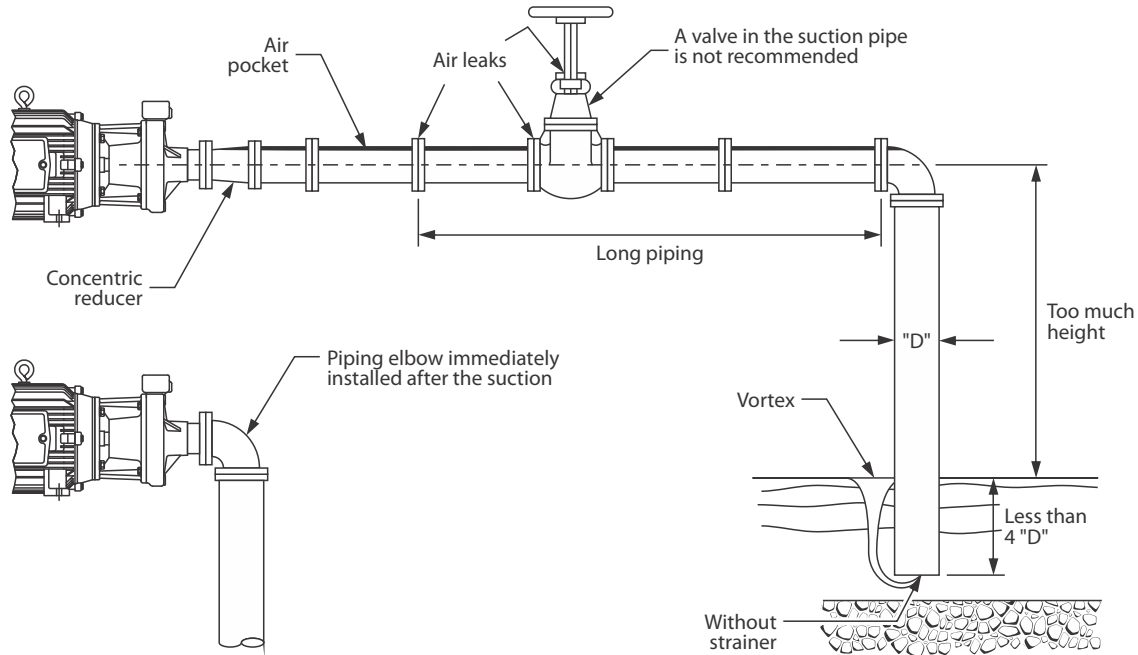
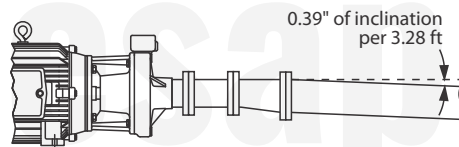

Figure 3 Inclination. Correct

Suction height - suction pipe should have a slope of 0.39" per 3.3 ft of suction. Never exceed 16.4 ft suction, considering friction. (Figure 3)



Incorrect

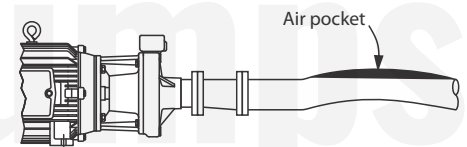
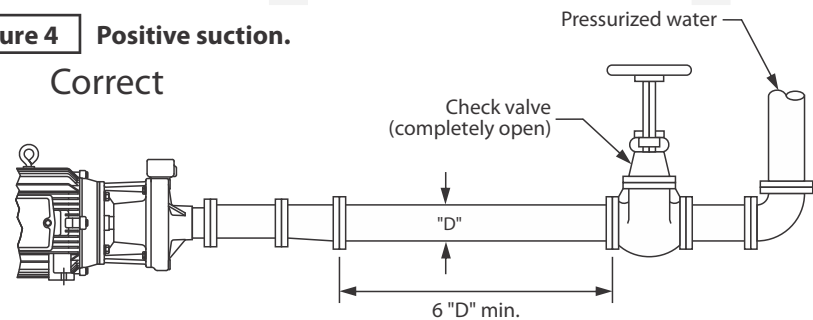

Figure 4 Positive suction. Correct

Positive/Drowned Suction - A gate valve is installed in the suction pipe to service the pump (Figure 4). Volute or body have plugs, and these must be removed to allow trapped air to escape.



► **Discharge pipe**

Use pipe or hose reinforced sufficiently robust to prevent destruction due to high pressure.

Figure 5 Positive suction.

Incorrect

A retention valve in the suction pipe is not recommended. If required, better install the valve in the discharge pipe.

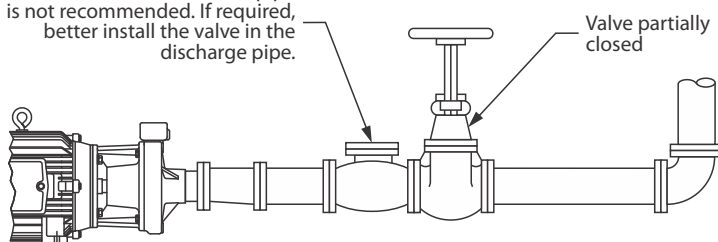

Due to the cost of energy or BHP necessary to overcome the friction generated by using a smaller diameter pipe, a larger diameter discharge pipe is commonly used than the required by the volute or body.

Figure 6 Discharge piping.

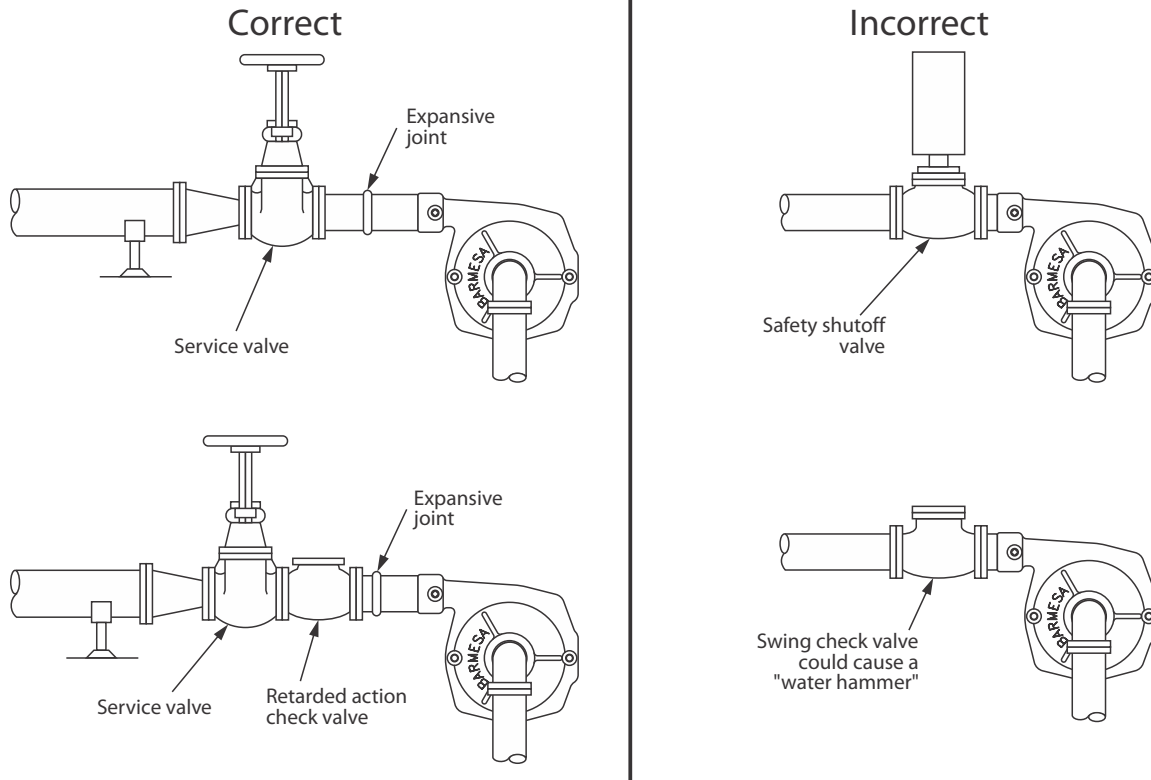

In order to determine the optimal size of the piping, compare the total cost of the equipment's operation (cost of the pump, control equipment, piping and energy consumption). By increasing the discharge diameter reasonably, it reduces the required BHP due to the low friction. Perform different tests using several piping diameters until you find the more convenient.

The pipe, valves, etc. should be perfectly align with the volutes suction and discharge centerlines, this to avoid any excessive loads on the pumps volute. If needed, install new expansive joints to protect the pump from excessive thermal or pressure forces.

► Pre-Operation

1. **Check Voltage and Phase** - Compare the voltage and phase information stamped on the pump name plate.

2. **Check Pump Rotation** - Improper motor rotation can result in poor pump performance and can damage the motor and/or pump. Check rotation on three phase units by momentarily applying power and observe the "kickback".

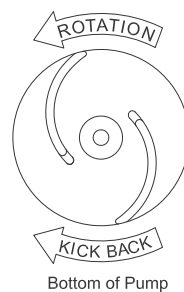

Kickback should always be in a counter-clockwise direction as viewed from motor end or opposite to impeller rotation. Impeller rotation is counter-clockwise as viewed from bottom of pump.

3. **Name Plate** - Record the information from the pump name plate to drawing in front of manual for future reference.

4. **Priming** - Every centrifugal pump must be primed (suction pipe and pump's body should have liquid), before operating.

Install the foot valve at the suction pipe *Figure 1* and fill with liquid the superior part of the pump's body. Sometimes air is trapped inside the body, to remove it you should uncap the male plug until the liquids spills out. Re-install the male plug using a sealant.



IMPORTANT! - Do not operate pump without priming first. Operating dry will damage seal.

▶ Starting

When starting for the first time your equipment check that the discharge valve is 90% closed. Gradually open the valve until the motor runs at full load (amperage plate). Never allow the amperage consumed by the pump exceeds the maximum permitted by the engine.

▶ Mechanical seal

Mechanical seals installed in this pumps are lubricated by water, there for the pump should not be operated dry. You will find the appropriate seal for each use and liquid to be pumped, check with your Barmesa Pumps distributor for more information.

▶ Stuffing box*

If the pump has graphite packing (stuffing box) consider the following:

- When the pump is placed into operation, the liquid will drip from the stuffing box; if this does not happen, loosen the nuts on the stuffing box until dripping occurs.
- After a few minutes of operation, gradually tighten the nuts until the drip decreases but does not stop.
- Once the pump has operated for a reasonable period and the dripping has not decreased to "a few drops per minute", it is necessary to tighten the nuts stuffing box. If tightening the nuts the required drip is not achieved, the graphite packing rings must be replaced.

▶ Frame*

All pumps come with factory lubricated bearings. It is very important to have oil in the oil tank. (Use oil DTE26). Change the oil every 1,000 hours of operation, considering a daily operation of 8 hours.

It is important not to overfill the oil tank because it would cause an increase in pressure by heating, affecting the bearings and seals. In normal operation, the frame temperature increases 122 °F above ambient temperature.

▶ Flexible coupling*

All pumps operated through flexible coupling or by pulleys and belts must be perfectly aligned to ensure smooth operation. In no case problems occur with flexible couplings if the pump-motor alignment is correct. All pumps are manufactured following this condition.

**For Barmesa pumps with universal transmission.*



IMPORTANT! - *Always unplug the pump before applying maintenance, service or repair to avoid electric shock.*

▶ Maintenance

Body and Impeller - All pump parts are removable by removing nuts and bolts. For body maintenance, disconnect the suction and discharge, and remove the body of the intermediate coupling. For maintenance of the impeller is not necessary to remove the suction or discharge, simply remove the body nuts; this would uncover the impeller. Examine and replace if it shows wear or damage.

When the impeller requires replacement, remove the screw of the shaft, and using a puller, remove the impeller being careful not to abuse the keyway of the shaft.

Mechanical Seal - To inspect or replace the shaft seal, remove the body and impeller. If any part shows wear or damage, replace both parts (stationary seat and rotary part). The rotating seal parts may be stuck together with the shaft, this happens when the seal has been assembled for a long time.

If the mechanical seal does not leak and there is need to open the pump for inspection or cleaning, *DO NOT* remove the seal, remove the spring only if the impeller needs to be removed. Once a seal has been in operation is very difficult to remove and reassembly without creating a seal leak.

▶ Disassembly

Mechanical Seal - Perform the steps above. Remove the rotating part. It may be necessary to remove the intermediate link to remove the stationary seat. To do this, remove the nuts and washers that attach the coupling to the motor. When removing the coupling, the steady part will move towards the front seat of the shaft and the sleeve. If the seat does not yield itself, push from the rear of the coupling.



Handle seal parts with extreme care. DO NOT damage lapped surfaces.

▶ Reassembly

Mechanical Seal - Identify all parts of *Figures 7 and 8*. The ring (6) and seat (1) are perfectly polished, so care must be taken not to scratch or smudge. The cleaning during the assembly process is very important.



IMPORTANT! - *All parts must be clean before reassembly.*

Step 1: Install the intermediate coupling if it was previously removed. Make sure the shaft and cavities, where will it seats, are clean. The shaft sleeve should not be sharp, but a radius of about 1/32". It is recommended that lightly polish the area of the shaft. If the shaft and it radius are perfectly polished, the seal can be relatively easily installed.

Figure 7 Mechanical Seal - Sectional View.

- 1 - Ceramic seat
- 2 - Seal seat Buna-N
- 3 - Inox. retainer
- 4 - Inox. jacket
- 5 - Inox. spring
- 6 - Carbon ring
- 7 - Elastomer Buna-N
- 8 - Inox. washer

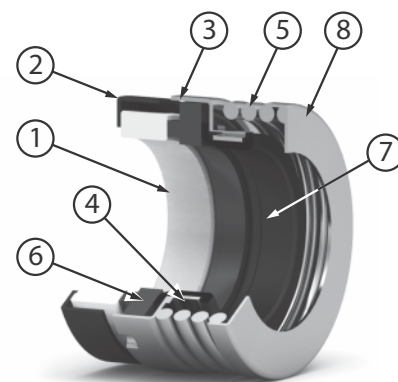

Step 2: Install the seat assembly (1 and 2) on the inside of the intermediate coupling, slightly moistening with water on the rubber parts (**do not use grease or oil**). This assembly should be done only manually, meaning without the use of an instrument.

Figure 8 Mechanical Seal - Assembly.

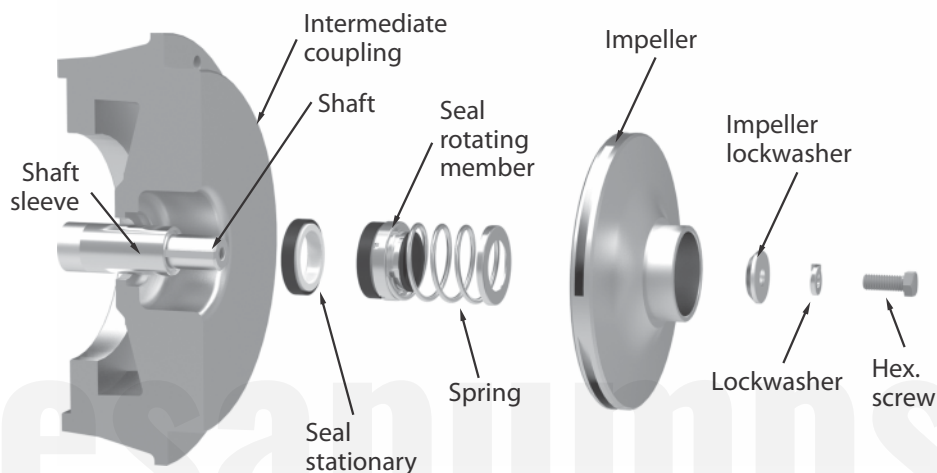

Step 3: Install the rotating portion of the seal without the spring. Moisten the arrow and the inside of the seal with some water (**do not use grease or oil**). With clean, dry hands, insert the rotating portion to the shaft, sliding it abuts the stationary seat. Once the seal is in place, insert the spring (5).

Step 4: Place the impeller and washers; tighten the hex screw.

GENERAL DIMENSIONS IA1 MODEL

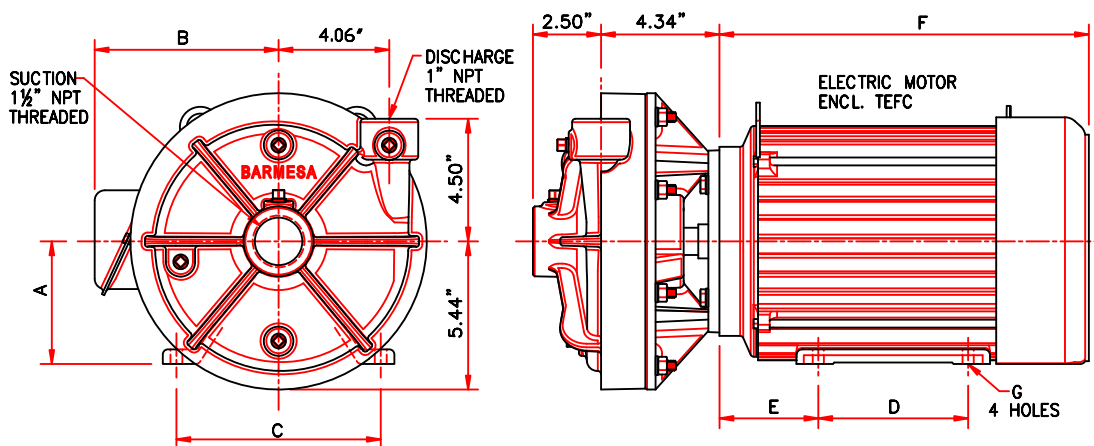

MODEL	CODE	HP	RPM	FASE	FRAME	A	B	C	D	E	F	G
IA1-3-2	62212007	3	3540	1	182JM	4.50	6.72	7.50	5.50	3.50	12.34	0.41
IA1-3-2	62212003	3	3540	3	143/5JM	3.50	5.88	5.50	5.00	2.59	11.41	0.34
IA1-5-2	62212008	5	3525	1	184JM	4.50	6.72	7.50	5.50	3.50	14.34	0.41
IA1-5-2	62212003	5	3525	3	182/4JM	4.50	7.56	7.50	5.50	2.75	13.14	0.41
IA1-7.5-2	62212009	7.5	3535	1	213JM	5.25	8.04	8.50	7.00	4.25	16.09	0.41
IA1-7.5-2	62212004	7.5	3535	3	213/5JM	5.25	8.60	8.50	7.00	3.50	15.88	0.41

ALL DIMENSIONS ARE IN INCHES.

GENERAL DIMENSIONS IA1 1/2 & IA1 1/2H MODELS

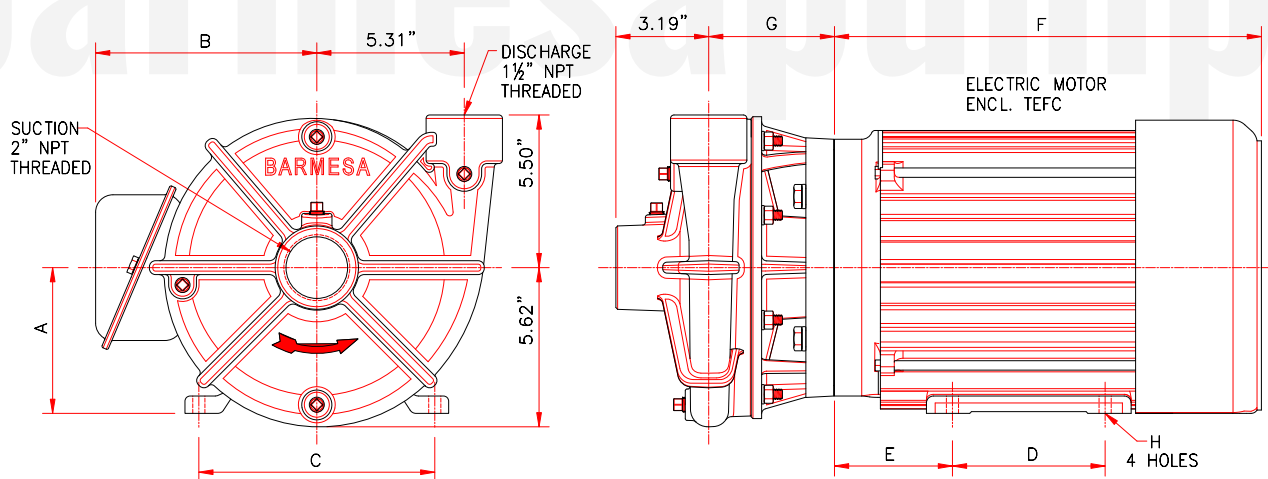

MODEL	CODE	HP	RPM	PHASE	FRAME	A	B	C	D	E	F	G	H
IA1-1/2-5-2	62212011	5	3500	3	182/4JM	4.50	7.56	7.50	5.50	2.75	13.15	4.27	0.41
IA1-1/2-5-2	62212018	5	3500	1	184JM	4.50	6.72	7.50	5.50	3.50	14.34	4.27	0.43
IA1-1/2-7.5-2	62212012	7.5	3500	3	182/4JM	4.50	8.60	7.50	5.50	2.75	13.15	4.27	0.41
IA1-1/2-7.5-2	62212019	7.5	3500	1	213JM	5.25	8.04	8.50	7.00	4.25	16.09	4.27	0.43
IA1-1/2-10-2	62212013	10	3500	3	213/5JM	5.25	8.60	8.50	7.00	3.25	15.89	4.54	0.41
IA1-1/2-15-2	62212014	15	3500	3	213/5JM	5.25	8.60	8.50	7.00	3.25	15.89	4.54	0.41
IA1-1/2-20-2	62212015	20	3500	3	254/6JM	6.25	10.50	10.0	10.0	4.00	20.72	5.28	0.53
IA1-1/2H-3-4	62212021	3	1750	3	182/4JM	4.50	7.56	7.50	5.50	2.75	13.15	4.40	0.41
IA1-1/2H-15-2	62212025	15	3500	3	213/5JM	5.25	8.60	8.50	7.00	3.25	15.88	4.53	0.41
IA1-1/2H-20-2	62212026	20	3500	3	254/6JM	6.25	10.50	10.0	10.0	4.00	20.72	5.40	0.53
IA1-1/2H-25-2	62212027	25	3500	3	284/6JM	7.00	11.0	11.0	11.0	4.50	23.12	5.40	0.53
IA1-1/2H-30-2	62212028	30	3500	3	284/6JM	7.00	11.0	11.0	11.0	4.50	23.12	5.40	0.53

ALL DIMENSIONS ARE IN INCHES.

GENERAL DIMENSIONS IA1½XH MODEL

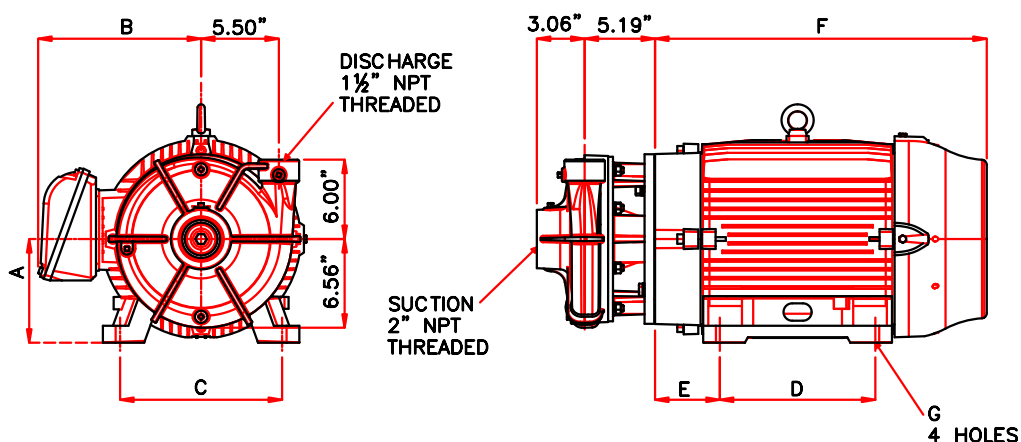

MODEL	CODE	HP	RPM	PHASE	FRAME	A	B	C	D	E	F	G
*IA1½HX-3-4	62212031	3	1750	3	182/4TCZ	4.50	7.56	7.50	5.50	2.75	13.12	0.41
*IA1½HX-5-4	62212033	5	1750	3	182/4TCZ	4.50	7.56	7.50	5.50	2.75	13.12	0.41
*IA1½HX-15-2	62212036	15	3500	3	213/5JM	5.25	8.60	8.50	7.00	3.25	15.88	0.41
IA1½HX-20-2	62212037	20	3500	3	254/6JM	6.25	10.48	10.00	10.00	4.00	20.73	0.53
IA1½HX-25-2	62212038	25	3500	3	284/6JM	7.00	11.07	11.00	11.00	4.50	23.05	0.53
IA1½HX-30-2	62212039	25	3500	3	284/6JM	7.00	11.07	11.00	11.00	4.50	23.05	0.53

ALL DIMENSIONS ARE IN INCHES
WITH 254JM SHAFT EXTENSION

GENERAL DIMENSIONS IA2 & IA2H MODELS

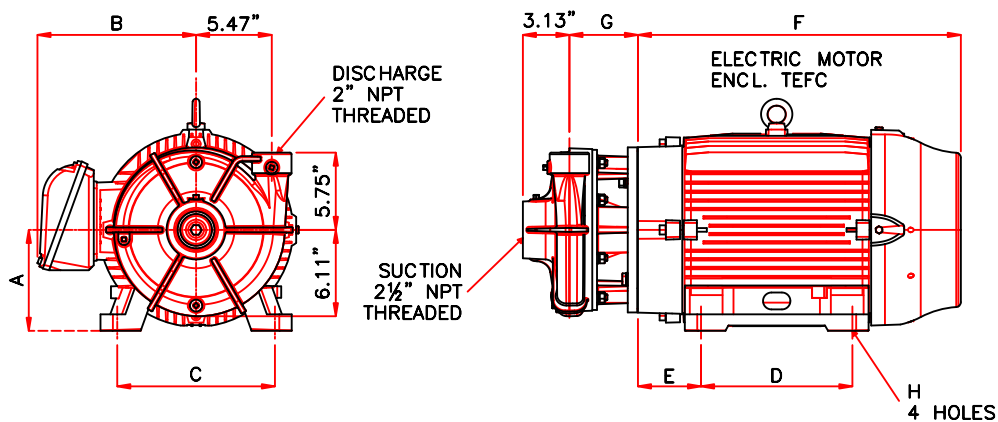

MODEL	CODE	HP	RPM	PHASE	FRAME	A	B	C	D	E	F	G	H
IA2-10-2	62212045	10	3500	3	213/5JM	5.25	8.67	8.50	7.00	3.25	15.89	4.53	0.41
IA2-15-2	62212046	15	3500	3	213/5JM								
IA2-20-2	62212047	20	3500	3	254/6JM	6.25	10.48	10.00	10.00	4.00	20.73	5.28	0.53
IA2-25-2	62212048	25	3500	3	284/6JM	7.00	11.07	11.00	11.00	4.50	23.05	5.22	
IA2H-25-2	62212056	25	3500	3	284/6JM	7.00	11.07	11.00	11.00	4.50	23.05	5.34	0.53
IA2H-30-2	62212057	30	3500	3	284/6JM								

ALL DIMENSIONS ARE IN INCHES

GENERAL DIMENSIONS IA2HH MODEL

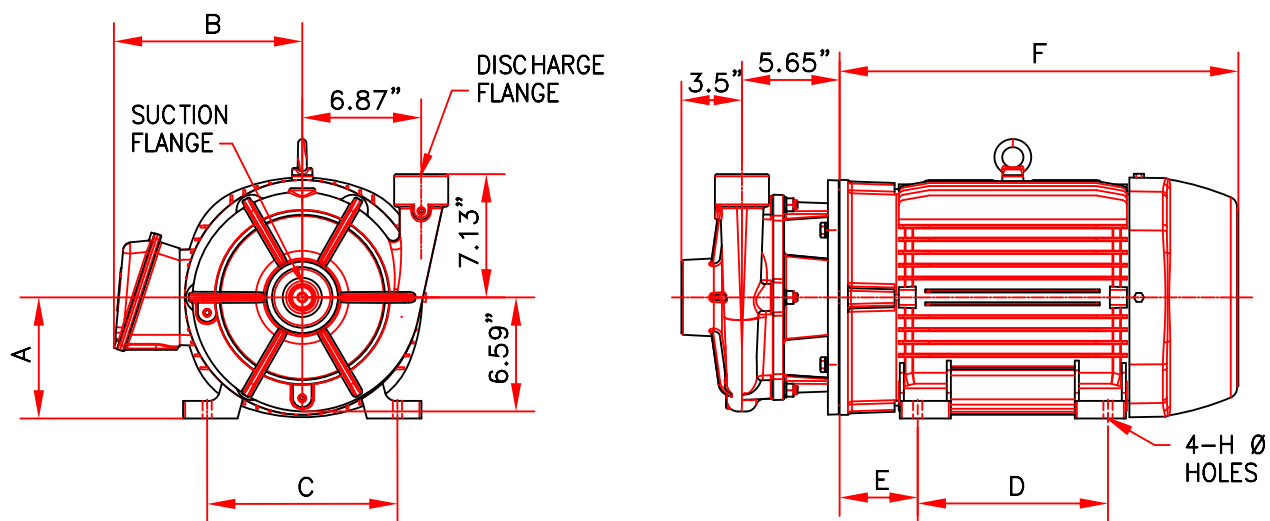

MODEL	CODE	HP	RPM	PHASE	FRAME	A	B	C	D	E	F	G
IA2HH-30-2	62212086	30	3500	3	284/6JM	7.00	11.07	11.00	11.00	4.50	23.05	0.53
IA2HH-40-2	62210287	40	3500	3	324/6JM	8.00	12.57	12.50	12.00	5.00	25.59	0.66

DIMENSIONS IN INCHES

GENERAL DIMENSIONS IA2EH MODEL

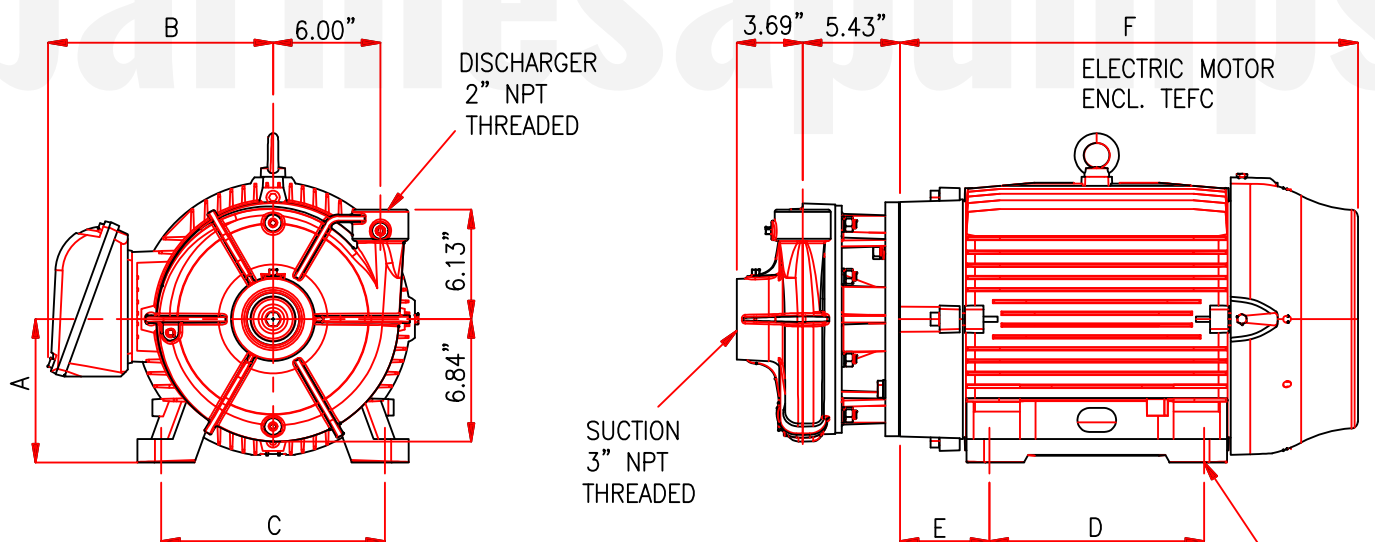

MODEL	CODE	HP	RPM	PHASE	FRAME	A	B	C	D	E	F	G
*IA2EH-5-4	62212063	5	3500	3	182/4TCZ	4.50	7.56	7.50	5.50	2.75	13.12	0.41
IA2EH-30-2	62212067	30	3500	3	284/6JM	7.00	11.07	11.00	11.00	4.50	23.05	0.53
IA2EH-40-2	62212068	40	3500	3	324/6JM	8.00	12.50	12.50	12.00	5.00	25.60	0.66
IA2EH-50-2	62212069	50	3500	3	324/6JM	8.00	12.50	12.50	12.00	5.00	25.60	0.66

G 4 HOLES

*WITH 284/6 JM SHAFT EXTENSION.

ALL DIMENSIONS ARE IN INCHES

UPDATE : 09/11/2023

GENERAL DIMENSIONS IA2½ MODEL

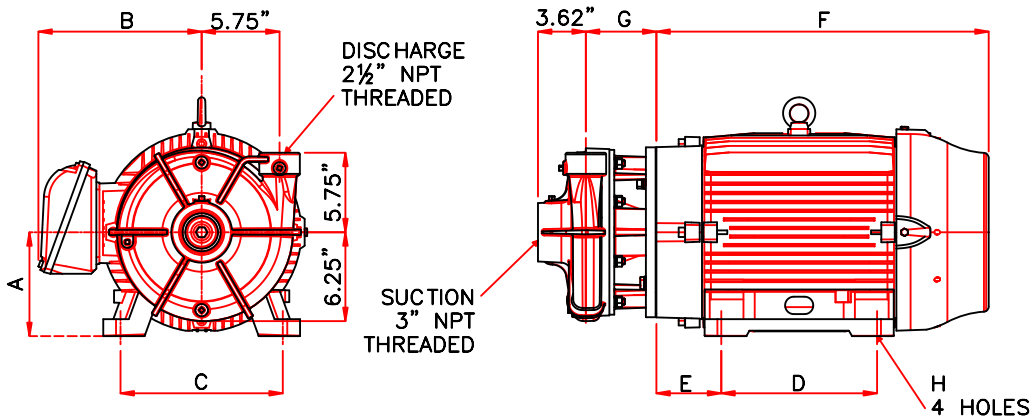

MODEL	CODE	HP	RPM	PHASE	FRAME	A	B	C	D	E	F	G	H
IA2-1/2-3-4	62212091	3	1750	3	182/4JM	4.50	7.54	7.50	5.50	2.75	13.15	4.47	0.41
IA2-1/2-5-4	62212093	5	1750	3	182/4JM	4.50	7.54	7.50	5.50	2.75	13.15	4.47	0.41
IA2-1/2-10-2	62212094	10	3500	3	213/5JM	5.25	8.67	8.50	7.00	3.25	15.89	4.72	0.41
IA2-1/2-15-2	62212095	15	3500	3	213/5JM	5.25	8.67	8.50	7.00	3.25	15.89	4.72	0.41
IA2-1/2-20-2	62212096	20	3500	3	254/6JM	6.25	10.48	10.00	10.00	4.00	20.73	5.47	0.53
IA2-1/2-25-2	62212097	25	3500	3	284/6JM	7.00	11.07	11.00	11.00	4.50	23.05	5.40	0.53
IA2-1/2-30-2	62212098	30	3500	3	284/6JM	7.00	11.07	11.00	11.00	4.50	23.05	5.40	0.53
IA2-1/2-40-2	62212099	40	3500	3	324/6JM	8.00	12.57	12.50	12.00	5.00	25.59	5.40	0.66

ALL DIMENSIONS ARE IN INCHES

GENERAL DIMENSIONS IA2½BJM MODEL

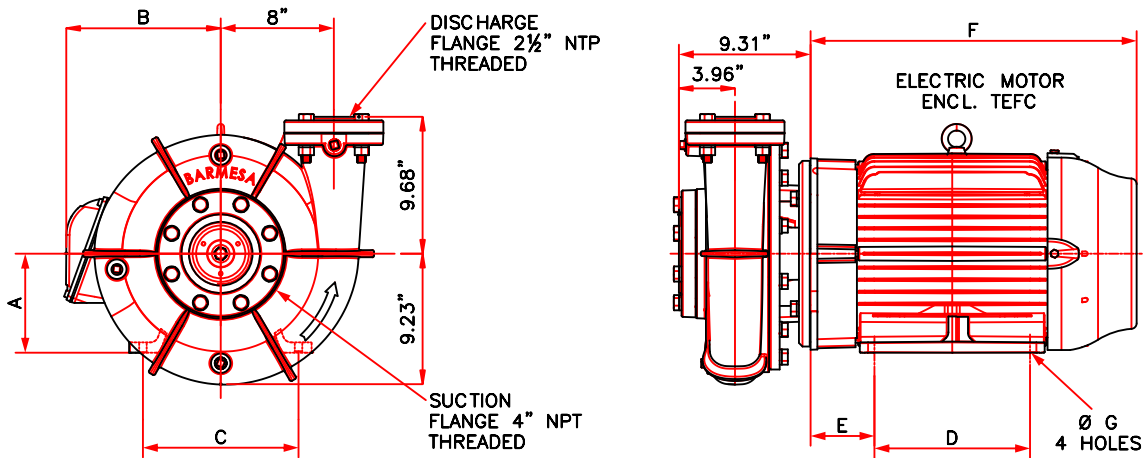

MODEL	CODE	HP	RPM	PHASE	FRAME	A	B	C	D	E	F	G
IA2.1/2BJM-15-4	62212116	15	1750	3	254/6JM	6.25	10.48	10.00	10.00	4.00	20.27	0.53
IA2.1/2BJM-20-4	62212117	20	1750	3	254/6JM							
IA2.1/2BJM-25-4	62212118	25	1750	3	284/6JM	7.00	10.91	11.00	11.00	4.50	23.05	
IA2.1/2BJM-30-4	62212119	30	1750	3	284/6JM							

ALL DIMENSIONS ARE IN INCHES.

GENERAL DIMENSIONS IA2½H MODEL

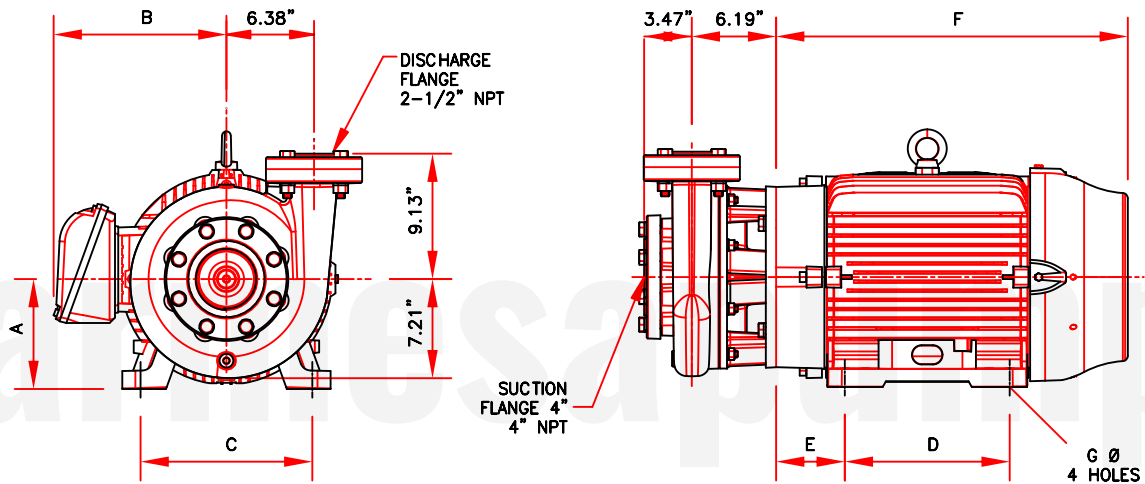

MODEL	CODE	H.P.	RPM	FRAME	A	B	C	D	E	F	G Ø
IA2-1/2H-40-2	62212105	40	3500	324/6JM	8.00"	12.57"	12.50"	12.00"	5.00"	25.59"	0.66"
IA2-1/2H-50-2	62212106	50	3500								
IA2-1/2H-60-2	62212107	60	3500	364/5JM	9.00"	16.02"	14.00"	12.25"	5.63"	27.53"	0.66"
IA2-1/2H-75-2	62212108	75	3500								
IA2-1/2H-100-2	62212109	100	3500	405TCZ	10.00"	18.09"	16.00"	13.75"	6.62"	31.52"	0.81"

DIMENSIONS IN INCHES

GENERAL DIMENSIONS IA3 / IA3H MODELS

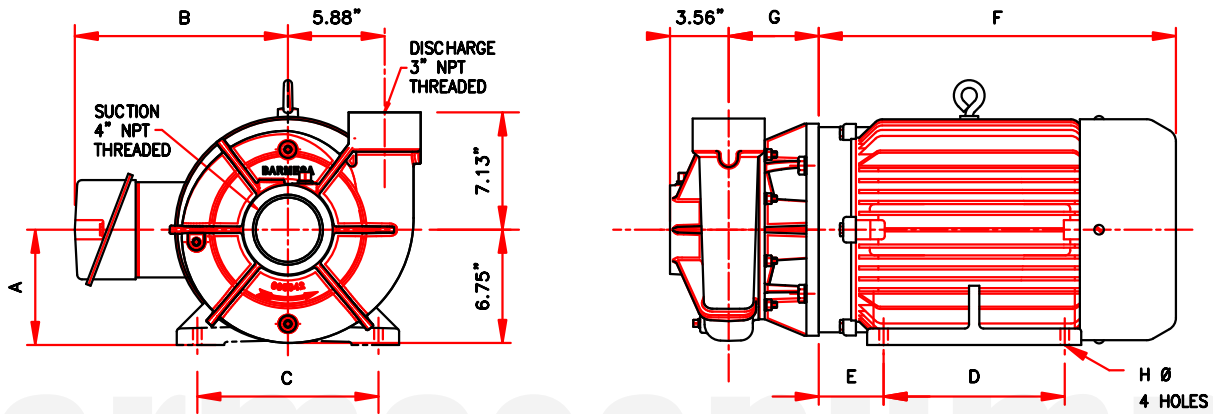

MODEL	PART No.	HP	RPM	PHASE	FRAME	A	B	C	D	E	F	G	H
IA3-3-4	62212121	3	1750	3	182/4JM	4.50	7.54	7.50	5.50	2.75	13.15	4.47	0.41
IA3-5-4	62212122	5	1750	3	182/4JM								
IA3-7.5-4	62212123	7.5	1750	3	213/5JM	5.25	8.67	8.50	7.00	3.25	15.89	4.72	
IA3-15-2	62212126	15	3500	3	213/5JM	6.25	10.48	10.00	10.00	4.00	20.73	5.40	
IA3-20-2	62212127	20	3500	3	254/6JM	7.00	11.07	11.00	11.00	4.50	23.05		
IA3-25-2	62212128	25	3500	3	284/6JM	8.00	12.57	12.50	12.00	5.00	25.53		
IA3-30-2	62212121	30	3500	3	284/6JM	8.00	12.57	12.50	12.00	5.00	25.53		
IA3-40-2	62212130	40	3500	3	324/6JM	9.00	16.02	14.00	12.25	5.63	27.53	0.66	
IA3-50-2	62212131	50	3500	3	324/6JM	9.00	16.02	14.00	12.25	5.63	27.53		
IA3H-30-2	62212135	30	3500	3	284/6JM	7.00	11.07	11.00	11.00	4.50	23.05	5.40	0.53
IA3H-40-2	62212136	40	3500	3	324/6JM	8.00	12.57	12.50	12.00	5.00	25.53		0.66
IA3H-50-2	62212137	50	3500	3	324/6JM	8.00	12.57	12.50	12.00	5.00	25.53		
IA3H-60-2	62212138	60	3500	3	364/5JM	9.00	16.02	14.00	12.25	5.63	27.53	5.40	0.66
IA3H-75-2	62212139	75	3500	3	364/5JM	9.00	16.02	14.00	12.25	5.63	27.53		

ALL DIMENSIONS ARE IN INCHES

GENERAL DIMENSIONS IA3BJM MODEL

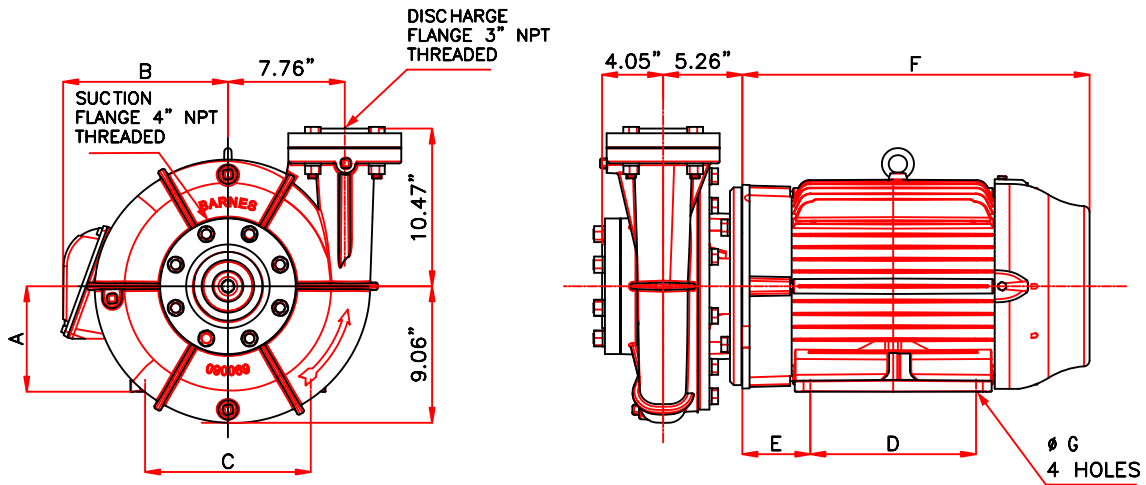

MODEL	CODE	HP	RPM	PHASE	FRAME	A	B	C	D	E	F	G
IA3BJM-15-4	62212145	15	1750	3	254/6JM	6.25	10.48	10.00	10.00	4.00	20.27	0.53
IA3BJM-20-4	62212146	20	1750	3	254/6JM							
IA3BJM-25-4	62212147	25	1750	3	284/6JM	7.00	10.91	11.00	11.00	4.50	23.05	
IA3BJM-30-4	62212148	30	1750	3	284/6JM							
IA3BJM-40-4	62212149	40	1750	3	324/6JM	8.00	12.56	12.50	12.00	5.00	25.55	0.66

DIMENSIONS IN INCHES

GENERAL DIMENSIONS IA4 MODEL

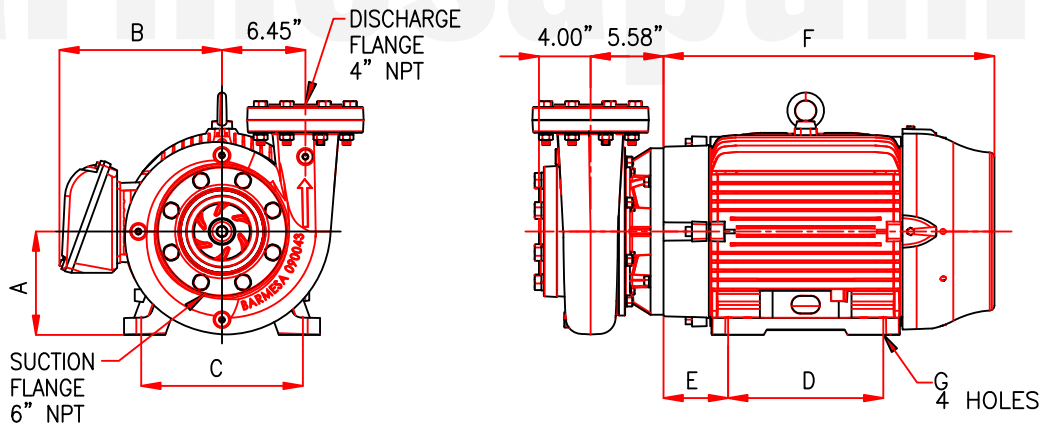

MODEL	MODEL	HP	RPM	FRAME	A	B	C	D	E	F	G Ø
IA4-10-4	62212153	10	1800	213/5JM	5.25	8.63	8.50	7.00	3.25	15.83	0.41
IA4-15-4	62212154	15	1800	254/6JM	6.25	10.48	10.00	10.00	4.00	20.27	0.53
IA4-20-4	62212155	20	1800	254/6JM							
IA4-40-2	62212161	40	3500	324/6JM	8.00	12.57	12.50	12.00	5.00	25.53	0.66
IA4-50-2	62212162	50	3500	324/6JM							
IA4-60-2	62212163	60	3500	364/5JM	9.00	16.02	14.00	12.25	5.63	27.53	
IA4-75-2	62212164	75	3500	364/5JM							
IA4-100-2	62212165	100	3500	405TCZ	10.00	18.09	16.00	13.75	6.62	31.52	0.81
IA4-125-2	62212166	125	3500	444JM	11.00	18.57	18.00	16.50	7.50	36.73	

DIMENSIONS IN INCHES

GENERAL DIMENSIONS IA4-7.5-4 MODEL

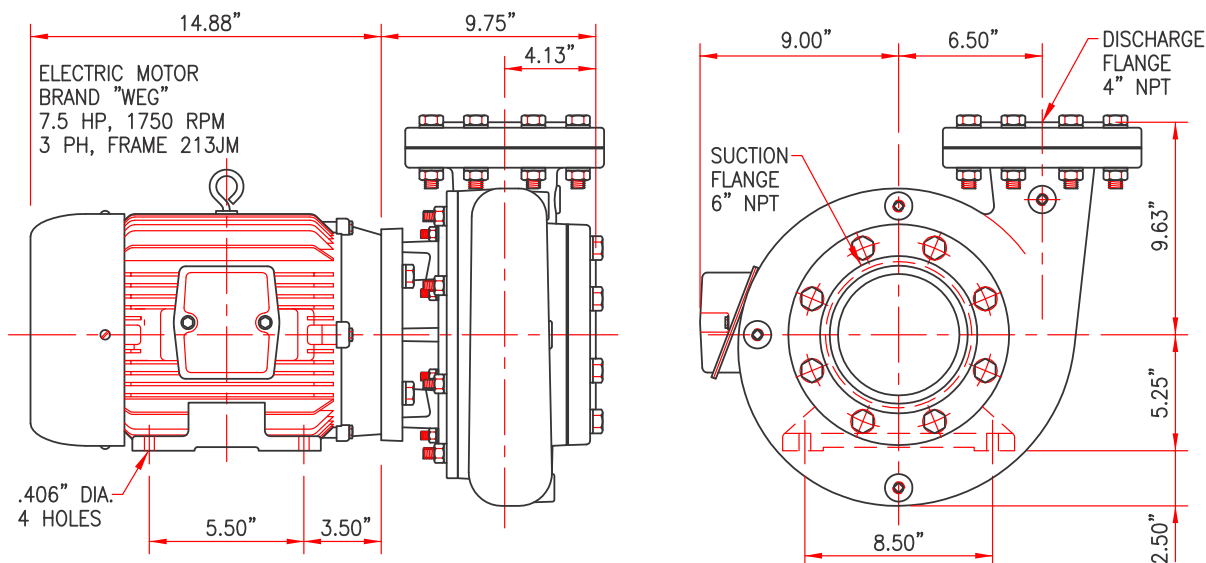

GENERAL DIMENSIONS IA4BJH MODEL

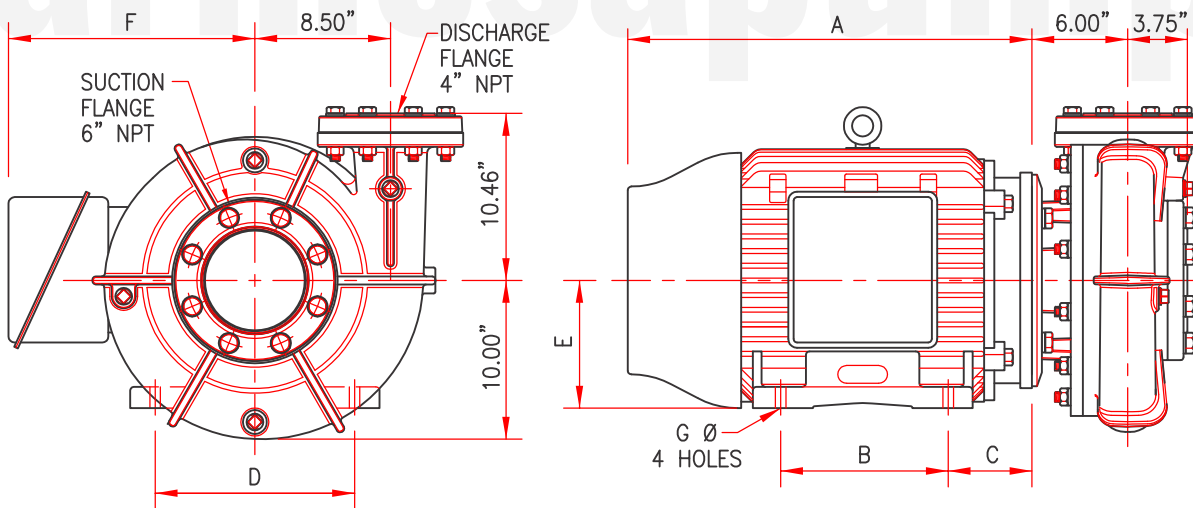

MODEL	HP	RPM	PHASE	FRAME	A	B	C	D	E	F
IA4BJH-20-4	20	1745	3	256JM	20.25"	10"	4.25"	10"	6.25"	9.9"
IA4BJH-25-4	25	1760	3	284JM	22.62"	9.5"	4.75"	11"	7"	12.94"
IA4BJH-30-4	30	1760	3	286JM	24.56"	11"	5.25"	12.5"	8"	15.44"
IA4BJH-40-4	40	1765	3	324JM	25.31"	10.5"	5.25"	12.5"	8"	15.44"
IA4BJH-50-4	50	1765	3	326JM	25.31"	12"	5.25"	12.5"	8"	15.44"
IA4BJH-60-4	60	1765	3	364JM	27"	11.25"	5.88"	14"	9"	16.44"

GENERAL DIMENSIONS IA6BJM-40-4 MODEL

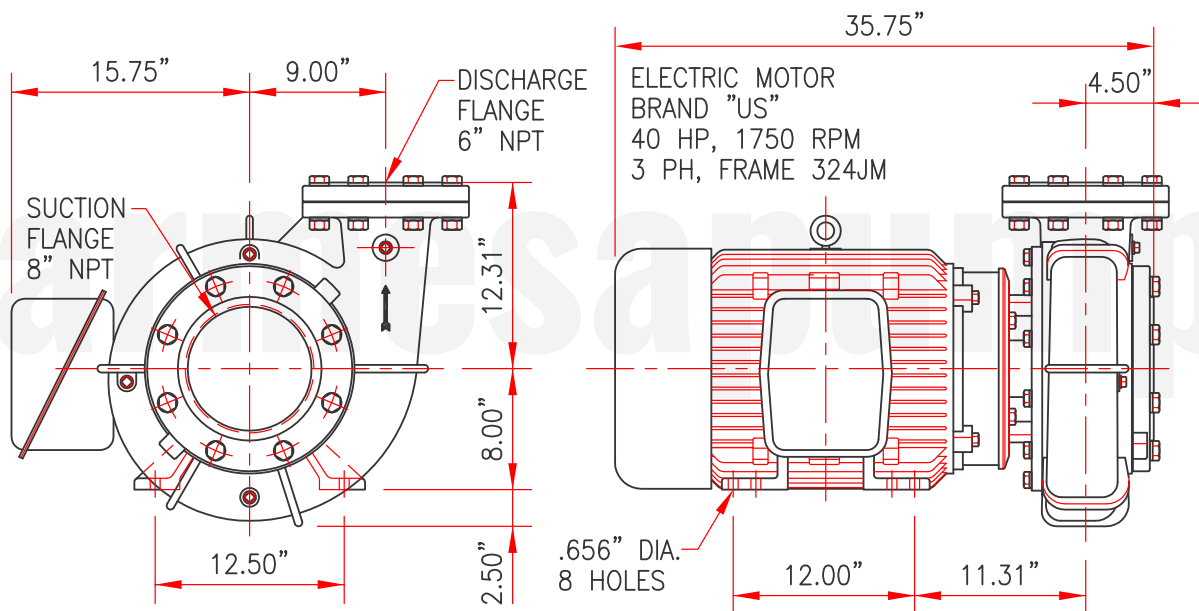

TYPICAL EXPLODED VIEW CENTRIFUGAL PUMP

MODELS:

- * IA1
- * IA1½
- * IA1½H
- * IA2
- * IA2H
- * IA2½
- * IA3
- * IA3H

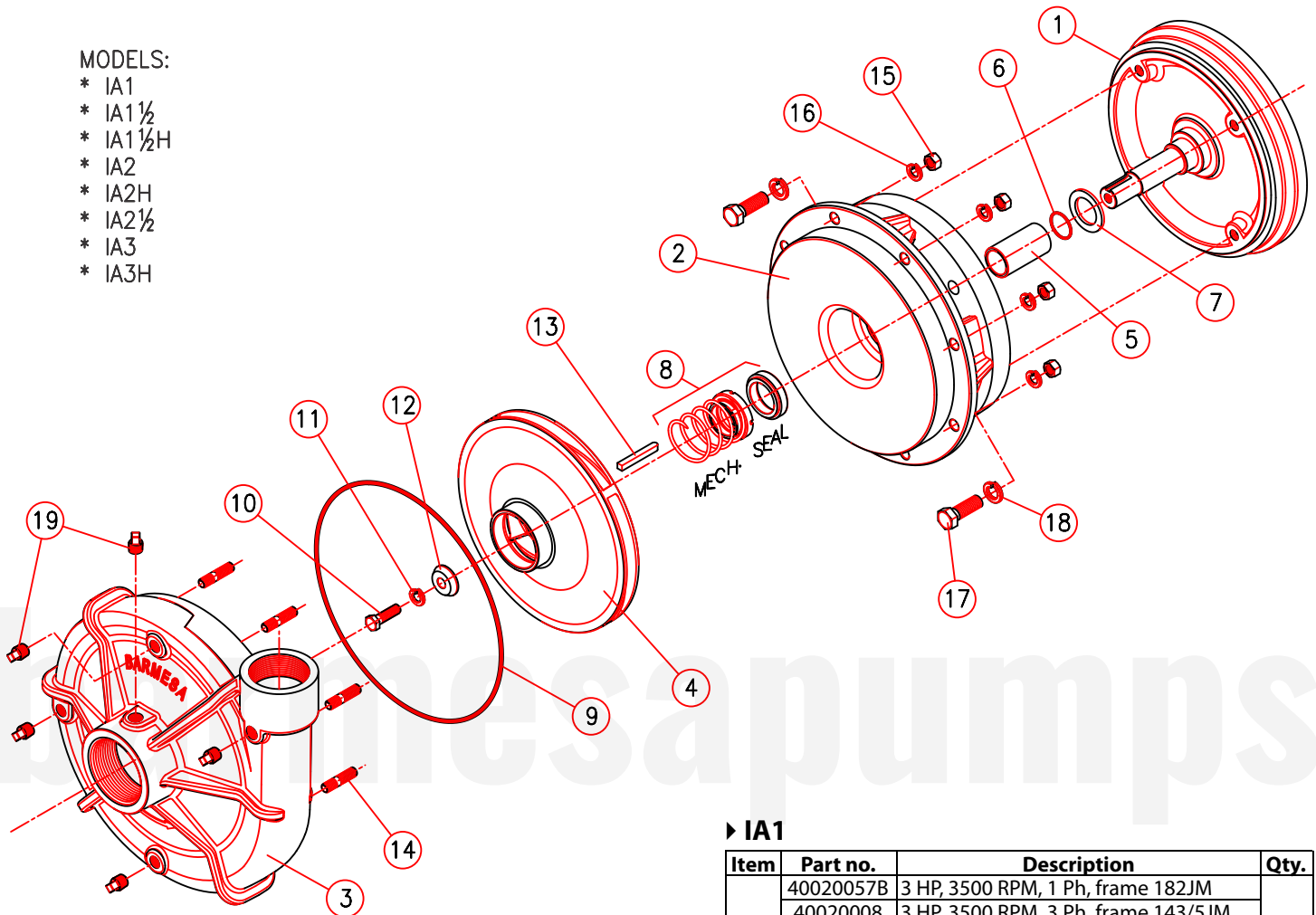

► IA1

Item	Part no.	Description	Qty.
1	40020057B	3 HP, 3500 RPM, 1 Ph, frame 182JM	-
	40020008	3 HP, 3500 RPM, 3 Ph, frame 143/5JM	
	40020059B	5 HP, 3500 RPM, 1 Ph, frame 184JM	
	40020011	5 HP, 3500 RPM, 3 Ph, frame 182/4JM	
	40020061B	7.5 HP, 3500 RPM, 1 Ph, frame 213JM	
	40020014	7.5 HP, 3500 RPM, 3 Ph, frame 213/5JM	
2	03010028	Intermediate Coupling, for 3 and 5 HP	1
	03010018	Intermediate Coupling, for 7.5 HP	
3	03090038	Volute Case	1
4	03140031	Impeller IA1-3-2, Ø 5.75"	1
	03140031B	Impeller IA1-5-2, Ø 6.81"	
	03140031C	Impeller IA1-7.5-2, Ø 7½"	
5	30400808	Shaft Sleeve	1
6	92010029J	O-Ring Shaft Sleeve	1
7	92010014	Slinger	1
8	31030131	Mechanical Seal	1
9	92010033	O-Ring	1
10	91010345C	Impeller's Screw	1
11	91010061	Lock Washer 3/8" SS	1
12	30400418	Impeller Washer	1
13	30400631	Shaft Key	1
14	91010303	Stud 3/8"-16x 1½"	8
15	91010413	Hex Nut 3/8"	8
16	91010012	Lock Washer 3/8" Steel	8
17	91010243	Cap Screw 3/8"-16 x 1¼"	4
18	91010012	Lock Washer 3/8" Steel	4
19	93010143	Pipe Plug ¼" NPT	5

To order any spare part please supply the model and serial number as shown on the nameplate, and the description and part number as shown in the parts list.

► IA1½

Item	Part no.	Description	Qty.
1	40020011	Motor 5 HP 3500 RPM 3Ph BC 182/4JM	-
	40020059B	Motor 5 HP 3500 RPM 1Ph BC 184JM	
	40020014	Motor 7½ HP 3500 RPM 3Ph BC 213/5JM	
	40020061B	Motor 7½ HP 3500 RPM 1Ph BC 213JM	
	40020017	Motor 10 HP 3500 RPM 3Ph BC 213/5JM	
	40020020	Motor 15 HP 3500 RPM 3Ph BC 213/5JM	
	40020023	Motor 20 HP 3500 RPM 3Ph BC 254/6JM	
2	03010028	Intermediate coupling for 5 and 7½ HP	1
	03010018	Intermediate coupling for 10 and 15 HP	
	03010051	Intermediate coupling for 20 HP	
3	03090039	Volute Case	1
4	03140032	Impeller IA1½ - 5 HP - Ø 6.75"	1
	03140032B	Impeller IA1½ - 7½ HP - Ø 7.50"	
	03140032C	Impeller IA1½ - 10 HP - Ø 8.00"	
	03140032D	Impeller IA1½ - 15 HP - Ø 9.00"	
	03140032E	Impeller IA1½ - 20 HP - Ø 9.00"	
5	30400808	Shaft sleeve for 5 HP to 15 HP	1
	30400812	Shaft sleeve for 20 HP	1
6	92010029M	O-ring shaft sleeve for 20 HP	1
	92010029J	O-ring shaft sleeve for 5 HP to 15 HP	
7	92010014	Slinger for 5 HP to 15 HP	1
	92010016	Slinger for 20 HP	
8	31030133	Mechanical seal 1.750" for 20 HP	1
	31030131	Mechanical seal 1.250" for 5 HP to 15 HP	
9	92010033	O-Ring	1
10	91010345C	Impeller's screw	1
11	91010061	Lock washer	1
12	30400418	Impeller washer	1
13	30400631	Shaft key	1
14	91010303	Stud 3/8	8
15	91010413	Hex nut 3/8	8
16	91010012	Lock washer 3/8	8
17	91010242	Cap screw 3/8 for 5 HP to 7½ HP	4
	91010263	Cap screw 1/2 for 10 HP to 20 HP	4
18	91010014	Lock washer 1/2 for 10 HP to 20 HP	4
	91010012	Lock washer 3/8 for 5 HP to 7½ HP	4
19	93010143	Pipe plug 1/4 npt	5

► IA1½H

Item	Part no.	Description	Qty.
1	40020009	3 HP,1800rpm, 3ph, frame 182T JM	-
	40020020	15 HP, 3530 rpm, 3 ph, frame 213/5 JM	
	40020023	20 HP, 3525 rpm, 3 ph, frame 256T JM	
	40020026	25 HP, 3530 rpm, 3 ph, frame 284T JM	
	40020029	30 HP, 3525 rpm, 3 ph, frame 286T JM	
2	03010028	Intermediate Coupling, for 3 HP	1
	03010018	Intermediate Coupling, for 15 HP	
	03010051	Intermediate Coupling, for 20 HP	
	03010020	Intermediate Coupling, for 25 & 30 HP	
3	03090039B	Volute Case	1
4	03140065G	Impeller IA1½H-3-4, Dia. 9.00" (shaft 7/8"Ø)	1
	03140065	Impeller IA1½H-15-2, Dia. 7.94" (shaft 7/8"Ø)	
	03140065B	Impeller IA1½H-20-2, Dia. 8.63" (shaft 1¼"Ø)	
	03140065C	Impeller IA1½H-25 & 30-2, Dia. 9.00"(shaft 1¼"Ø)	
5	30400808	Shaft Sleeve, for 3 HP to 15 HP	1
	30400812	Shaft Sleeve, for 20 to 30 HP	
6	92010029J	O-Ring Shaft Sleeve for 3 & 15 HP	1
	92010029M	O-Ring Shaft Sleeve for 20 to 30 HP	
7	92010014	Slinger, for 3 & 15 HP	1
	92010016	Slinger, for 20 & 30 HP	
8	31030131	Mech. Seal, for 3 & 15 HP	1
	31030133	Mech. Seal, for 20 & 30 HP	
9	92010033	O-Ring	1
10	91010345C	Impeller's Screw, for 3 & 15 HP	1
	91010351	Impeller's Screw, for 20 & 30 HP	
11	91010061	Lock Washer, 3/8" SS, for 3 & 15 HP	1
	91010062	Lock Washer, ½" SS, for 20 & 30 HP	
12	30400418	Impeller Washer, for 3 HP & 15 HP	1
	30400416	Impeller Washer, for 20 & 30 HP	
13	30400631	Shaft Key, for 3 & 15 HP	1
	30400633	Shaft Key, for 20 & 30 HP	
14	91010303	Stud 3/8"-16 x 1½"	8
15	91010413	Hex Nut 3/8"	8
16	91010012	Lock Washer 3/8"	8
17	91010243	Cap Screw, 3/8"-16 x 1" for 3 HP	4
	91010263	Cap Screw, ½"-13 x 1½" for 15 & 20 HP	
	91010282	Cap Screw, 5/8"-11 x 1½" for 25 & 30 HP	
18	91010012	Lock Washer, 3/8" Steel, for 3 HP	4
	91010014	Lock Washer, ½" Steel, for 15 HP - 20 HP	
	91010015	Lock Washer, 5/8" Steel, for 25 to 30 HP	
19	93010143	Pipe Plug ¼" NPT	5

To order any spare part please supply the model and serial number as shown on the nameplate, and the description and part number as shown in the parts list.

► IA2

Item	Part no.	Description	Qty.
1	40020006	2 HP 1750 RPM 3 PH frame 143/5	-
	40020017	10 HP 3500 RPM 3 PH frame 213/5	
	40020020	15 HP 3500 RPM 3 PH frame 213/5	
	40020023	20 HP 3500 RPM 3 PH frame 254/6	
	40020026	25 HP 3500 RPM 3 PH frame 284/6	
	40020029	30 HP 3500 RPM 3 PH frame 284/6	
2	03010028	Intermediate coupling 2 HP	1
	03010018	Intermediate coupling 10 & 15 HP	
	03010051	Intermediate coupling 20 HP	
	03010020	Intermediate coupling 25 and 30 HP	
3	03090040	Volute Case	1
4	03140033G	Impeller IA2 - 2 HP - 4 Ø9.00"(shaft 7/8"Ø)	1
	03140033	Impeller IA2 for 10 HP - 2 Ø7.56" (shaft 7/8"Ø)	
	03140033B	Impeller IA2 for 15 HP - 2 Ø8.31", (shaft 7/8"Ø)	
	03140033C	Impeller IA2 for 20 - 30 HP-2 Ø9.000", (shaft 1.1/4"Ø)	
5	30400808	Shaft Sleeve for 2 to 15 HP	1
	30400812	Shaft Sleeve for 20 to 30 HP	
6	92010029J	O-Ring Shaft Sleeve for 2 to 15 HP	1
	92010029M	O-Ring Shaft Sleeve for 20 to 30 HP	
7	92010014	Slinger for 3-15 HP	1
	92010016	Slinger for 20-50 HP	
8	31030131	Mech. Seal, for 2 to 15 HP	1
	31030133	Mech. Seal, for 20 to 30 HP	
9	92010033	O-Ring	1
10	91010345	Impeller's Screw 3/8 X1" SS 2 HP	1
	91010345C	Impeller's Screw 3/8 X1" SS10 to 15 HP	
	91010351	Impeller's Screw 3/8 X1" SS 20 to 30 HP	
11	91010061	Lock Washer 3/8" SS 2 to 15 HP	1
	91010062	Lock Washer 1/2" SS 20 to 30 HP	
12	30400418	Impeller Washer for 2 to 15 HP	1
	30400416	Impeller Washer for 20 to 30 HP	
13	30400631	Shaft Key 3/16", for 2 to 15 HP	1
	30400633	Shaft Key 1/4", for 20 to 30 HP	
14	91010303	Stud 3/8X1½	8
15	91010413	Hex. Nut 3/8"	8
16	91010012	Lock Washer 3/8"	8
17	91010242	Cap Screw, 3/8 x 1" for 2 HP	4
	91010263	Cap Screw, 1/2 x 1-1/2" for 10 to 20 HP	
	91010282	Cap Screw, 5/8 x 1-1/2" for 25 to 30 HP	
18	91010012	Lock Washer 3/8" for 2 HP	4
	91010014	Lock Washer 1/2" for 10 to 20 HP	
	91010015	Lock Washer 5/8" for 25 to 30 HP	
19	93010143	Pipe Plug 1/4"	5

To order any spare part please supply the model and serial number as shown on the nameplate, and the description and part number as shown in the parts list.

► IA2H

Item	Part. No.	Description	Qty.
1	40020026	25 HP 3500 RPM 3 Ph frame 284/6	1
	40020029	30 HP 3500 RPM 3 Ph frame 284/6	
2	03010020	Intermediate coupling	1
3	03090040B	Volute case	1
4	03140034H	Impeller IA2H - 25 HP Ø8.31" (shaft 1¼"Ø)	1
	03140034I	Impeller IA2H - 30 HP Ø9.00" (shaft 1¼"Ø)	
5	30400812	Shaft sleeve	1
6	92010029M	O-Ring shaft sleeve	1
7	92010016	Slinger	1
8	31030133	Mechanical seal	1
9	92010033	O-Ring	1
10	91010351	Impeller screw 1/2 X 1" SS	1
11	91010062	Lock washer 1/2" SS	1
12	30400416	Impeller washer	1
13	30400633	Shaft key 1/4"	1
14	91010303	Stud 3/8 X 1-1/2	8
15	91010413	Hex. Nut 3/8"	8
16	91010012	Lock Washer 3/8"	8
17	91010282	Cap Screw 5/8 X 1-1/2"	4
18	91010015	Lock Washer 5/8"	4
19	93010143	Pipe Plug 1/4"	5

To order any spare part please supply the model and serial number as shown on the nameplate, and the description and part number as shown in the parts list.

▶ IA2½

Item	Part no.	Description	Qty.
1	40020009	3 HP, 1750 RPM, 3 F, frame 182/4 JM	-
	40020012	5 HP, 1750 RPM, 3 F, frame 182/4 JM	
	40020017	10 HP, 3500 RPM 3 F, frame 213/5 JM	
	40020020	15 HP, 3500 RPM 3 F, frame 213/5 JM	
	40020023	20 HP, 3500 RPM 3 F, frame 254/6 JM	
	40020026	25 HP, 3500 RPM 3 F, frame 284/6 JM	
	40020029	30 HP, 3500 RPM, 3 F, frame 284/6 JM	
	40020032	40 HP 3500 RPM, 3 F, frame 324/6 JM	
2	03010028	Intermediate coupling, for 3 & 5 HP	1
	03010018	Intermediate coupling, for 10 & 15 HP	
	03010051	Intermediate coupling, for 20 HP	
	03010020	Intermediate coupling, for 25 & 30 HP	
3	03090041	Volute case	1
4	3140034K	Impeller IA2½ for 3 HP - Ø7.31" (shaft 7/8"Ø)	1
	3140034K	Impeller IA2½ for 5 HP - Ø8.38" (shaft 7/8"Ø)	
	03140034	Impeller IA2½ for 10 HP - Ø6.94" (shaft 7/8"Ø)	
	03140034	Impeller IA2½ for 15 HP - Ø6.94" (shaft 7/8"Ø)	
	3140034B	Impeller IA2½ for 20 HP - Ø7.69" (shaft 1-1/4"Ø)	
	3140034C	Impeller IA2½ for 25 HP - Ø8.44" (shaft 1-1/4"Ø)	
	3140034D	Impeller IA2½ for 30 HP - Ø8.88" (shaft 1-1/4"Ø)	
	3140034E	Impeller IA2½ for 40 HP - Ø9.00" (shaft 1-1/4"Ø)	
5	30400808	Shaft sleeve, for 3 to 15 HP	1
	30400812	Shaft sleeve, for 20 to 40 HP	
6	92010029J	O-Ring shaft sleeve, for 3 to 15 HP	1
	92010029M	O-Ring shaft sleeve, for 20 to 40 HP	
7	92010014	Slinger, for 3 to 15 HP	1
	92010016	Slinger, for 20 to 40 HP	
8	31030131	Mech. seal, for 3 to 15 HP	1
	31030133	Mech. seal, for 20 to 40 HP	
9	92010033	O-Ring	1
10	91010345C	Impeller's screw, for 3 to 15 HP	1
	91010351	Impeller's screw, for 20 to 40 HP	
11	91010061	Lock washer 3/8" SS, for 3 to 15 HP	1
	91010062	Lock washer 1/2" SS, for 20 to 40 HP	
12	30400418	Impeller washer, for 3 to 15 HP	1
	30400416	Impeller washer, for 20 to 40 HP	
13	30400631	shaft Key, for 3 to 15 HP	1
	30400633	shaft Key, for 20 to 40 HP	
14	91010303	Stud 3/8" X 1-1/2"	8
15	91010413	hex. Nut 3/8"	8
16	91010012	Lock washer 3/8"	8
17	91010243	Cap screw 3/8 x 1-1/4" for 3 & 5 HP	4
	91010263	Cap screw 1/2 x 1-1/2" for 10 to 20 HP	
	91010282	Cap screw 5/8 x 1-1/2" for 25 to 40 HP	
18	91010012	Lock washer 3/8" for 3 & 5 HP	4
	91010014	Lock washer 1/2" for 10 to 20 HP	
	91010015	Lock washer 5/8" for 25 to 40 HP	
19	93010143	Pipe Plug 1/4" NPT	5

To order any spare part please supply the model and serial number as shown on the nameplate, and the description and part number as shown in the parts list.

TYPICAL EXPLODED VIEW CENTRIFUGAL PUMP

MODEL:
* IA2HH

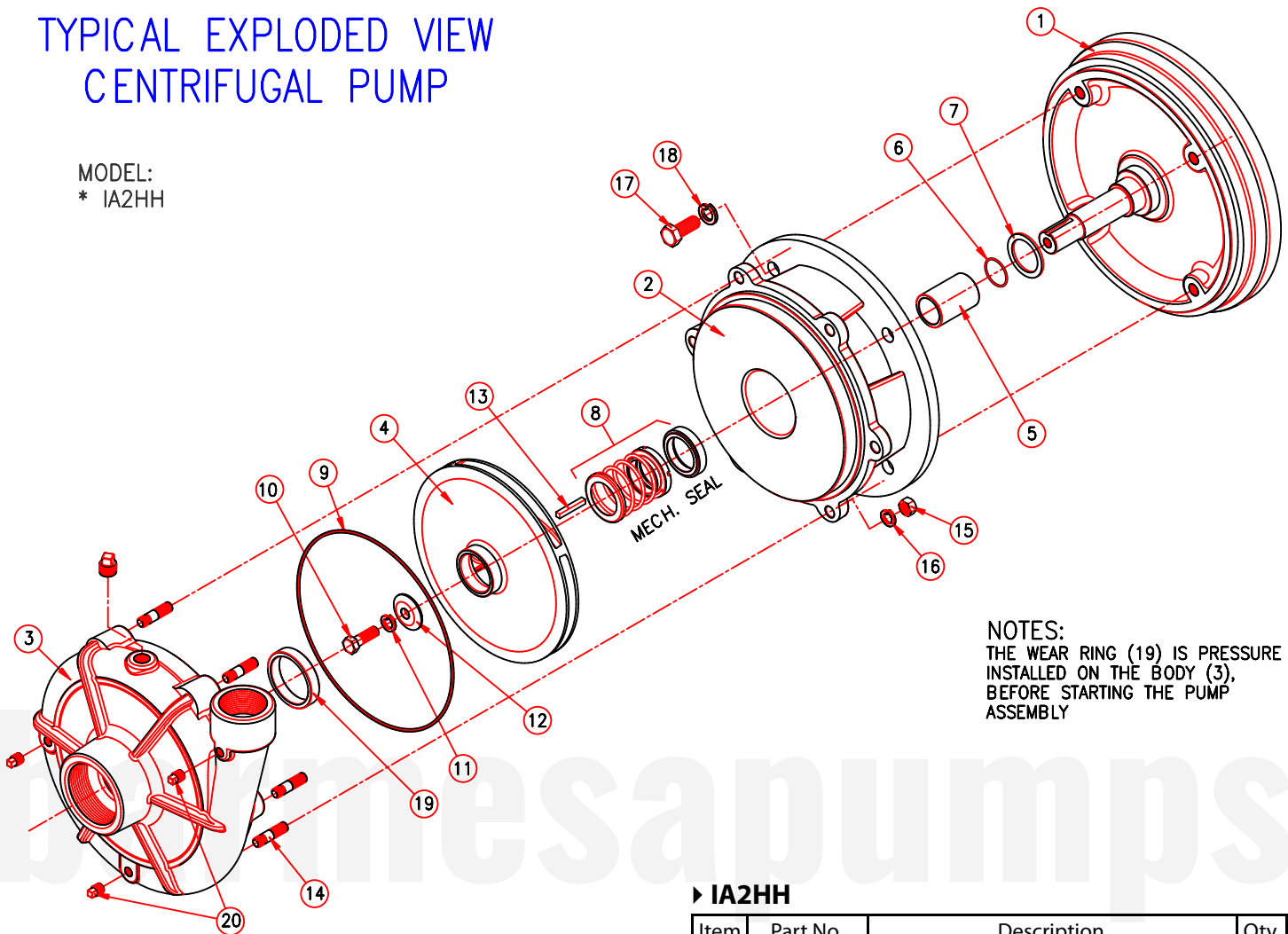

NOTES:
THE WEAR RING (19) IS PRESSURE
INSTALLED ON THE BODY (3),
BEFORE STARTING THE PUMP
ASSEMBLY

► IA2HH

Item	Part No.	Description	Qty.
1	40020029	30 HP, 3500 RPM, 3 Ph, frame 284/6JM	1
	40020032	40 HP, 3500 RPM, 3 Ph, frame 324/6JM	
2	03010061	Intermediate coupling	1
3	03090093	Volute case	1
4	03140092B	Impeller IA2HH -30 HP- Ø 9.450"	1
	03140092C	Impeller IA2HH -40 HP- Ø 9.925"	
5	030400837	Shaft sleeve	1
6	92010029M	Shaft sleeve O-ring	1
7	92010016	Slinger	1
8	31030133	Mechanical seal	1
9	92010089	O-ring	1
10	91010351	Impeller cap screw 1/2 x 1-1/2" SS	1
11	91010062	Lock washer 1/2" SS	1
12	30400416	Impeller washer	1
13	30400633	Shaft key	1
14	91010310	Stud 1/2 x 2"	6
15	91010415	Hex nut 1/2"	6
16	91010014	Lock washer 1/2"	6
17	91010282	Cap screw 5/8" x 1-1/2"	4
18	91010015	Lock washer 5/8"	4
19	30400328	Wear ring	1
20a	93010142	Pipe plug 1/2"	1
20b	93010143	Pipe plug 1/4"	3

To order any spare part please supply the model and serial number as shown on the nameplate, and the description and part number as shown in the parts list.

TYPICAL EXPLODED VIEW CENTRIFUGAL PUMP

MODELS:
* IA2½BJM
* IA3BJM

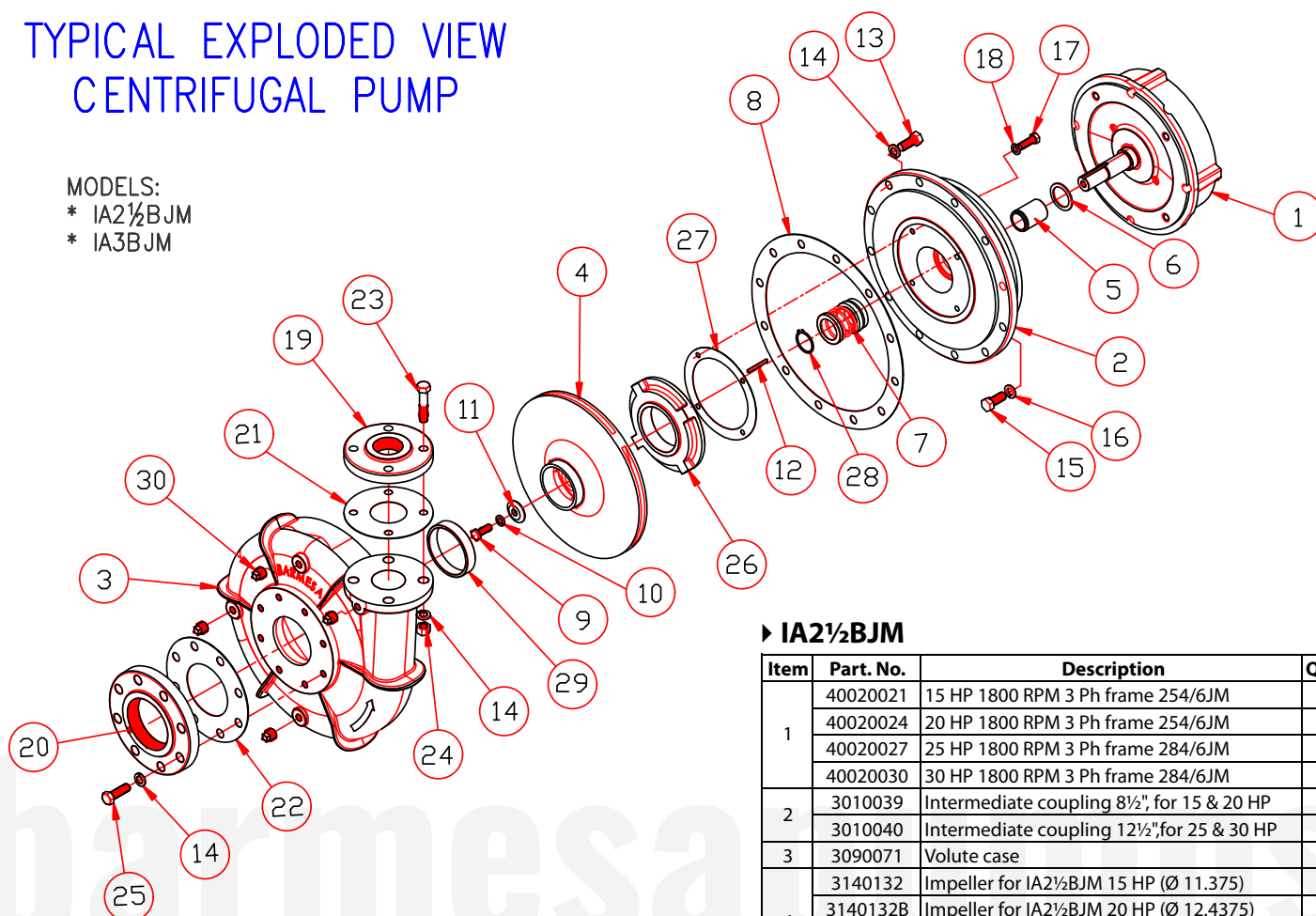

► IA2½BJM

Item	Part. No.	Description	Qty.
1	40020021	15 HP 1800 RPM 3 Ph frame 254/6JM	1
	40020024	20 HP 1800 RPM 3 Ph frame 254/6JM	1
	40020027	25 HP 1800 RPM 3 Ph frame 284/6JM	1
	40020030	30 HP 1800 RPM 3 Ph frame 284/6JM	1
2	3010039	Intermediate coupling 8½", for 15 & 20 HP	1
	3010040	Intermediate coupling 12½",for 25 & 30 HP	1
3	3090071	Volute case	1
4	3140132	Impeller for IA2½BJM 15 HP (Ø 11.375)	1
	3140132B	Impeller for IA2½BJM 20 HP (Ø 12.4375)	1
	3140132C	Impeller for IA2½BJM 25 HP (Ø 13.187)	1
	3140132D	Impeller for IA2½BJM 30 HP (Ø 13.50)	1
5	30400815	Shaft sleeve	1
6	92010016	Slinger	1
7	31030133	Mechanical seal	1
8	92010162	Body gasket	1
9	91010351	Cap screw 1/2" x 1½" SS	1
10	91010062	Lock washer 1/2" SS	1
11	30400416	Impeller washer	1
12	30400639	Shaft key	1
13	91010282	Cap screw 5/8" x 1½"	12
14	91010015	Lock washer 5/8"	24
15	91010263	Cap screw 1/2" x 1½" for 15 & 20 HP	4
	91010282	Cap screw 5/8" x 1½" for 25 & 30	
16	91010014	Lock washer 1/2" for 15 & 20 HP	4
	91010015	Lock washer 5/8" for 25 & 30	
17	91010244	Cap screw 3/8" x 1½"	4
18	91010012	Lock washer 3/8"	4
19	03060013	Flange discharge 2½"	1
20	03060006	Flange suction 4"	1
21	92010175	Flange gasket 2½"	1
22	92010156	Flange gasket 4"	1
23	91010285	Cap screw 5/8" x 3"	4
24	91010416	Hex nut 5/8"	4
25	91010283	Cap screw 5/8" x 2"	8
26	03190010B	Wear plate	1
27	92010191	Wear plate gasket	1
28	31010008	Retaining ring	1
29	30400316	Wear ring	1
30	93010142	Pipe plug 1/2"	4

To order any spare part please supply the model and serial number as shown on the nameplate, and the description and part number as shown in the parts list.

► IA3

Item	Part No.	Description	Qty.
1	40020009	3 HP 1750 RPM 3Ph, frame 182/4 JM	-
	40020012	5 HP 1750 RPM 3Ph, frame 182/4	
	40020015	7.5 HP 1750 RPM 3Ph, frame 213/5	
	40020020	15 HP 3500 RPM 3Ph, frame 213/5	
	40020023	20 HP 3500 RPM 3Ph, frame 254/6	
	40020026	25 HP 3500 RPM 3Ph, frame 284/6	
	40020029	30 HP 3500 RPM 3Ph, frame 284/6	
	40020032	40 HP 3500 RPM 3Ph, frame 324/6	
	40020034	50 HP 3500 RPM 3Ph, frame 324/6	
2	03010028	Intermediate coupling for 3 and 5 HP	1
	03010018	Intermediate coupling for 7.5 and 15 HP	
	03010051	Intermediate coupling for 20 HP	
	03010020	Intermediate coupling for 25 to 50 HP	
3	03090042	Volute case	1
4	03140035I	Impeller IA3 - 3 HP - 4 Ø7.50" (shaft 7/8")	1
	03140035J	Impeller IA3 - 5 HP - 4 Ø8.40" (shaft 7/8")	
	03140035H	Impeller IA3 - 7.5 HP - 4 Ø9" (shaft 7/8")	
	03140035	Impeller IA3 - 15 HP - 2 Ø6.938 (shaft 7/8")	
	03140035B	Impeller IA3 - 20 HP - 2 Ø6.938 (shaft 7/8")	
	03140035C	Impeller IA3 - 25 HP - 2 Ø7.50 (shaft 1¼")	
	03140035D	Impeller IA3 - 30 HP - 2 Ø8 (shaft 1¼")	
	40020035E	Impeller IA3 - 40 HP - 2 Ø8.75 (shaft 1¼")	
5	30400808	Shaft sleeve for 3 to 15 HP	1
	30400812	Shaft sleeve for 20 to 50 HP	
6	92010029J	O-ring shaft sleeve for 3 to 15 HP	1
	92010029M	O-ring shaft sleeve for 20 to 50 HP	
7	92010014	Slinger, for 3 to 15 HP	1
	92010016	Slinger, for 20 to 50 HP	
8	31030131	Mecanical seal for 3 to 15 HP	1
	31030133	Mecanical seal for 20 to 50 HP	
9	92010033	O-Ring	1
10	91010345	Impeller's screw 3/8" x 1" SS for 3 to 15 HP	1
	91010351	Impeller's screw 1/2" x 1½" SS for 20 to 50 HP	
11	91010061	Lock washer 3/8" SS for 3 to 15 HP	1
	91010062	Lock washer 1/2" SS for 20 to 50 HP	
12	30400418	Impeller washer for 3 to 15 HP	1
	30400416	Impeller washer for 20 to 50 HP	
13	30400631	Shaft key 3/16" for 3 to 15 HP	1
	30400633	Shaft key 1/4" for 20 to 50 HP	
14	91010303	Stud 3/8" x 1½"	8
15	91010413	Hex nut 3/8"	8
16	91010012	Lock washer 3/8"	8
17	91010242	Cap screw 3/8" x 1" for 3 and 5 HP	4
	91010263	Cap screw 1/2" x 1½" for 7.5 to 20 HP	
	91010282	Cap screw 5/8" x 1½" for 25 to 50 HP	
18	91010012	Lock washer 3/8" for 3 and 5 HP	4
	91010014	Lock washer 1/2" for 7.5 to 20 HP	
	91010015	Lock washer 5/8" for 25 to 50 HP	
19a	93010143	Pipe plug 1/4"	3
19b	93010142	Pipe plug 1/2"	1

► IA3H

Item	Part No.	Description	Qty.
1	40020029	30 HP, 3500 RPM, 3 ph, frame 284/6 JM	1
	40020032	40 HP, 3500 RPM, 3 ph, frame 324/6 JM	
	40020034	50 HP, 3500 RPM, 3 ph, frame 324/6 JM	
	40020036	60 HP, 3500 RPM, 3 ph, frame 364/5 JM	
	40020038	75 HP, 3500 RPM, 3 ph, frame 364/5 JM	
2	03010020	Intermediate coupling	1
3	03090042B	Volute case	1
4	03140066	Impeller IA3H for 30 HP, Ø 6.875"	1
	03140066B	Impeller IA3H for 40 HP, Ø 7.50"	
	03140066C	Impeller IA3H for 50 HP, Ø 7.94"	
	03140066D	Impeller IA3H for 60 HP, Ø 8.50"	
	03140066E	Impeller IA3H for 75 HP, Ø 9.00"	
5	030400812	Shaft sleeve	1
6	92010029M	O-Ring shaft sleeve	1
7	92010016	Slinger	1
8	31030133	Mechanical seal	1
9	92010033	O-Ring	1
10	91010351	Impeller screw	1
11	91010062	Lock washer, 1/2" SS	1
12	30400416	Impeller washer	1
13	30400633	Shaft key	1
14	91010303	Stud 3/8-16x 1-1/2"	8
15	91010413	Hex nut 3/8"	8
16	91010012	Lock washer 3/8"	8
17	91010282	Cap screw, 5/8 x 1-1/2"	4
18	91010015	Lock washer 5/8"	4
19a	93010142	Pipe plug 1/4" NPT	3
19b	93010143	Pipe plug 1/2" NPT	1

To order any spare part please supply the model and serial number as shown on the nameplate, and the description and part number as shown in the parts list.

► IA3BJM

Item	Part No.	Description	Qty.
1	40020021	Motor 15 HP 1800 RPM 3ph frame 254/6JM	1
	40020024	Motor 20 HP 1800 RPM 3ph frame 254/6JM	
	40020027	Motor 25 HP 1800 RPM 3ph frame 284/6JM	
	40020030	Motor 30 HP 1800 RPM 3ph frame 284/6JM	
	40020033	Motor 40 HP 1800 RPM 3ph frame 324/6JM	
2	03010039	Intermediate coupling 8.5", for 15 & 20 HP	1
	03010040	Intermediate coupling 12.5", for 25 to 40 HP	
3	03090069	Volute case	1
4	03140133	Impeller for 15 HP (Ø 10.188")	1
	3140133B	Impeller for 20 HP (Ø 11.125")	
	3140133C	Impeller for 25 HP (Ø 11.812")	
	3140133D	Impeller for 30 HP (Ø 12.437")	
	3140133F	Impeller for 40 HP (Ø 13.50")	
5	30400815	Shaft sleeve SS	1
6	92010016	Slinger	1
7	31030133	Mechanical seal	1
8	92010162	Body gasket	1
9	91010351	Cap screw 1/2 x 1-1/2" SS	1
10	91010062	Lock washer 1/2" SS	1
11	30400416	Impeller washer	1
12	30400639	Shaft key	1
13	91010282	Cap screw 5/8" x 1-1/2"	12
14	91010015	Lock washer 5/8"	24
15	91010263	Cap screw 1/2" x 1-1/2" for 15 & 20 HP	4
	91010282	Cap screw 5/8" x 1-1/2" for 25 to 40 HP	
16	91010014	Lock washer 1/2" for 15 & 20 HP	4
	91010015	Lock washer 5/8" for 25 to 40 HP	
17	91010244	Cap screw 3/8 x 1-1/2"	4
18	91010012	Lock washer 3/8"	4
19	03060004	Discharge flange 3"	1
20	03060006	Suction flange 4"	1
21	92010155	Flange gasket 3"	1
22	92010156	Flange gasket 4"	1
23	91010285	Cap screw 5/8" x 3"	4
24	91010416	Hex nut 5/8"	4
25	91010283	Cap screw 5/8" x 2"	8
26	03190010B	Wear plate	1
27	92010191	Wear plate gasket	1
28	31010008	Retaining ring	1
29	30400316	Wear ring	1
30	93010142	Pipe plug 1/2"	4

TYPICAL EXPLODED VIEW CENTRIFUGAL PUMP

MODEL
* IA1½XH

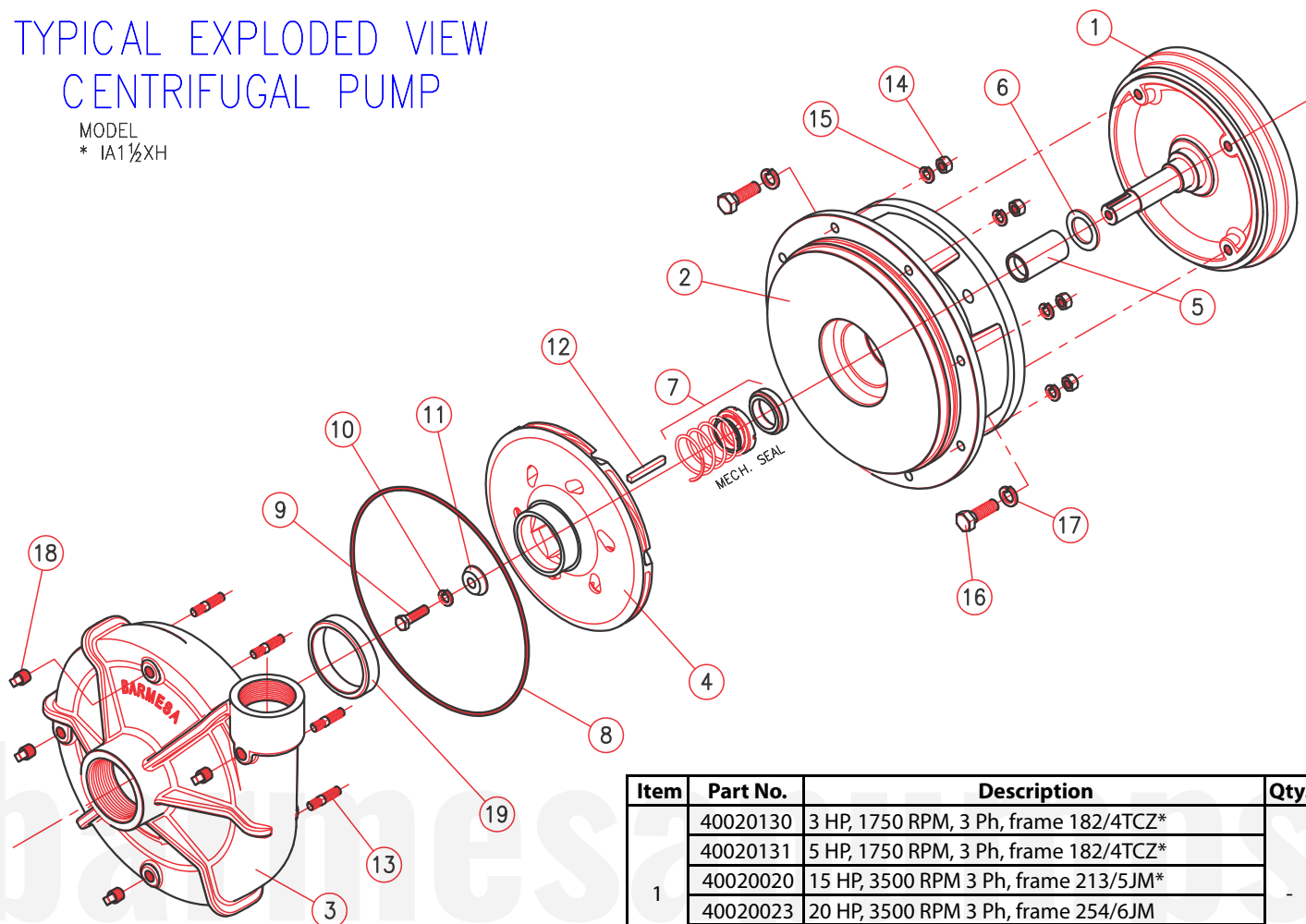

Item	Part No.	Description	Qty.
1	40020130	3 HP, 1750 RPM, 3 Ph, frame 182/4TCZ*	-
	40020131	5 HP, 1750 RPM, 3 Ph, frame 182/4TCZ*	
	40020020	15 HP, 3500 RPM 3 Ph, frame 213/5JM*	
	40020023	20 HP, 3500 RPM 3 Ph, frame 254/6JM	
	40020026	25 HP, 3500 RPM 3 Ph, frame 284/6JM	
	40020029	30 HP, 3500 RPM, 3 Ph, frame 284/6JM	
2	03010050	Intermediate coupling, for 3 to 20 HP	1
	03010050B	Intermediate coupling, for 25 and 30 HP	
3	03090079	Volute case	1
	03140076	Impeller for 15 HP-2, Ø7.25"	
4	03140076B	Impeller for 20 HP-2, Ø8.38"	1
	03140076C	Impeller for 3 HP-4, 5 HP-4 and 25 HP-2, Ø9.19"	
5	30400829	Shaft sleeve	1
6	92010016	Slinger	1
7	31030133	Mechanical seal	1
8	92010033	O-ring	1
9	91010351	Impeller's screw	1
10	91010062	Lock washer, 1/2" SS	1
11	30400416	Impeller washer	1
12	30400633	Shaft key	1
13	91010303	Stud 3/8 x 1-1/2"	8
14	91010413	Hex nut 3/8"	8
15	91010012	Lock washer 3/8"	8
16	91010263	Cap screw, 1/2 x 1-1/2" for 3 to 20 HP	4
	91010282	Cap screw, 5/8-11 x 1-1/2" for 25 and 30 HP	
17	91010014	Lock washer, 1/2" steel, for 3 to 20 HP	4
	91010015	Lock washer, 5/8" steel, for 25 and 30 HP	
18	93010143	Pipe plug 1/4" NPT	4
19	30400324	Wear ring	1

*With 254/6 JM shaft extension

To order any spare part please supply the model and serial number as shown on the nameplate, and the description and part number as shown in the parts list.

TYPICAL EXPLODED VIEW CENTRIFUGAL PUMP

MODEL
* 1A2½H

NOTES:

TO INSTALL THE SLEEVE
1.-THE SLEEVE MUST BE TORCH
HEATED AND INSTALLED ON THE
MOTOR'S SHAFT.
2.-LET IT COOL AFTER
INSTALLATION.

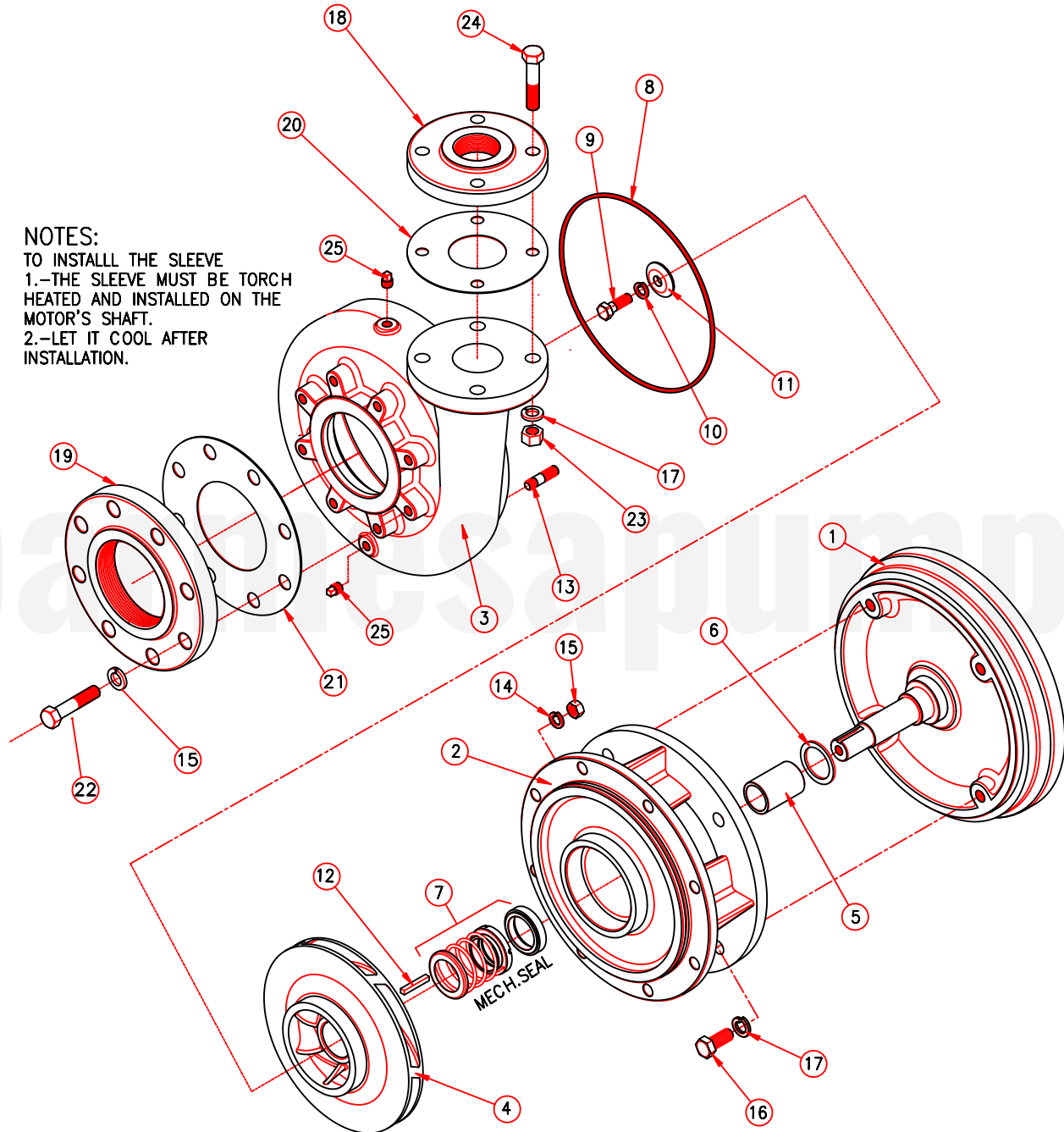

To order any spare part please supply the model and serial number as shown on the nameplate, and the description and part number as shown in the parts list.

▶ IA2½H

Item	Part No.	Description	Qty.
1	40020032	40 HP, 3500 RPM, 3ph, frame 324/6 JM	1
	40020034	50 HP, 3500 RPM, 3ph, frame 324/6 JM	
	40020036	60 HP, 3500 RPM, 3ph, frame 364/5 JM	
	40020038	75 HP, 3500 RPM, 3ph, frame 364/5 JM	
	40020040	100 HP, 3500 RPM, 3ph, frame 405 TCZ	
2	03010065	Intermediate coupling	1
3	03090094	Volute case	1
4	03140142	Impeller IA2½H for 100 HP, diam. 10.197" (shaft 1-¼"Ø)	1
	03140142B	Impeller IA2½H for 75 HP, diam. 9.842" (shaft 1-¼"Ø)	
	03140142C	Impeller IA2½H for 60 HP, diam. 9.055" (shaft 1-¼"Ø)	
	03140142D	Impeller IA2½H for 50 HP, diam. 8.464" (shaft 1-¼"Ø)	
	03140142E	Impeller IA2½H for 40 HP, diam. 7.875" (shaft 1-¼"Ø)	
5	30400838	Shaft sleeve	1
6	92010016	Slinger	1
7	31030411	Mechanical seal	1
8	92010090	O-ring	1
9	91010351	Cap screw 1/2" x 1-1/2" SS	1
10	91010062	Lock washer 1/2" SS	1
11	30400416	Impeller washer	1
12	30400633	Shaft key 1/4"	1
13	91010310	Stud 1/2" x 2"	8
14	91010014	Lock washer 1/2"	8
15	91010415	Hex. nut 1/2"	8
16	91010282	Cap screw 5/8" x 1-1/2"	4
17	91010015	Lock washer 5/8"	16
18	03060013	Discharge flange 2-1/2"	1
19	03060006	Suction flange 4"	1
20	92010175	Flange gasket 2-1/2"	1
21	92010156	Flange gasket 4"	1
22	91010285	Cap screw 5/8" x 3"	4
23	91010416	Hex. nut 5/8"	12
24	91010283	Cap screw 5/8" x 2"	8
25	93010143	Pipe plug 1/4" NPT	2

To order any spare part please supply the model and serial number as shown on the nameplate, and the description and part number as shown in the parts list.

TYPICAL EXPLODED VIEW CENTRIFUGAL PUMP

MODELS:
* IA2EH

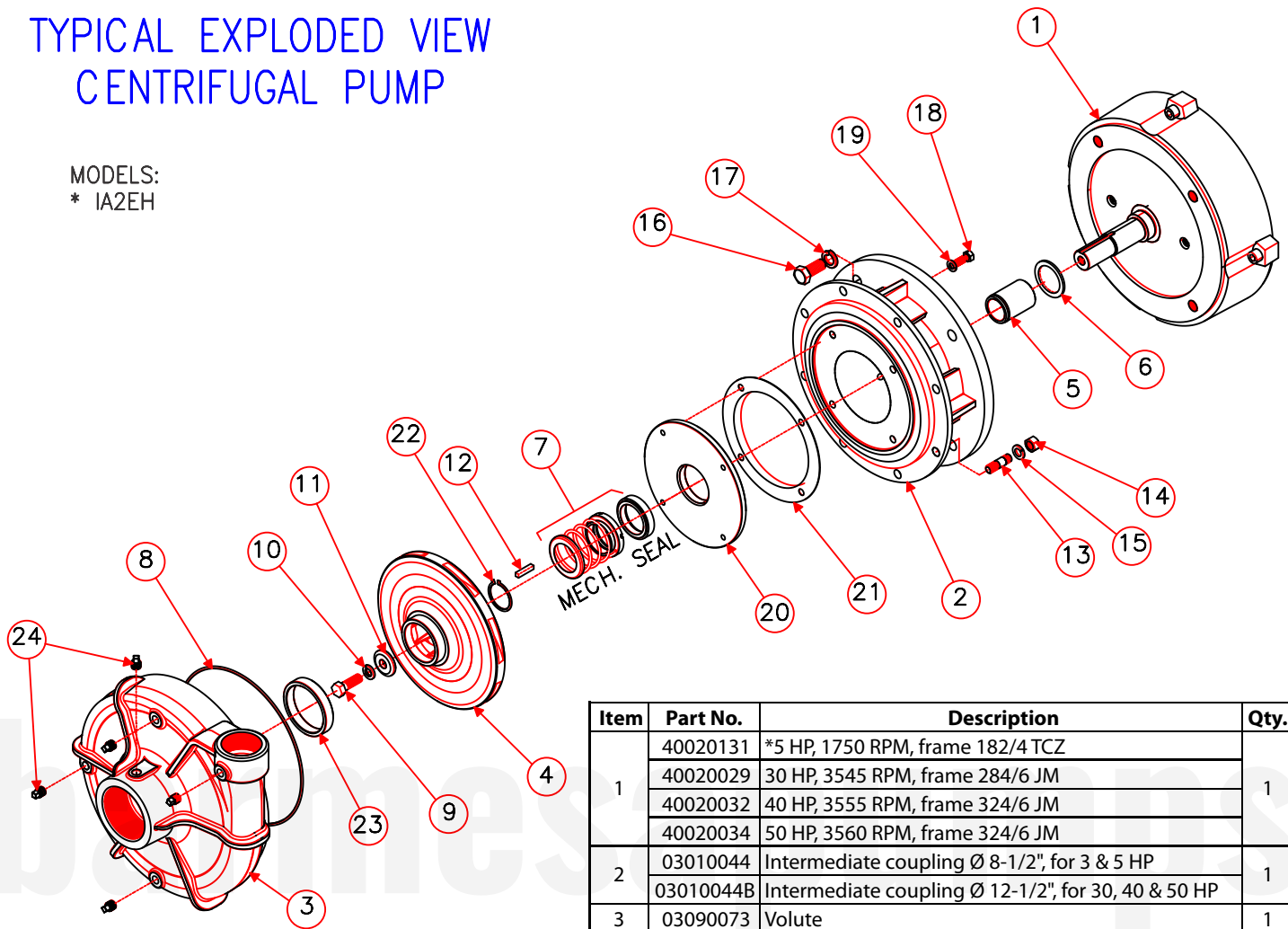

Item	Part No.	Description	Qty.
1	40020131	*5 HP, 1750 RPM, frame 182/4 TCZ	1
	40020029	30 HP, 3545 RPM, frame 284/6 JM	
	40020032	40 HP, 3555 RPM, frame 324/6 JM	
	40020034	50 HP, 3560 RPM, frame 324/6 JM	
2	03010044	Intermediate coupling Ø 8-1/2", for 3 & 5 HP	1
	03010044B	Intermediate coupling Ø 12-1/2", for 30, 40 & 50 HP	
3	03090073	Volute	1
4	03140063	Impeller IA2EH - 30 HP Ø 9.25"	1
	03140063B	Impeller IA2EH 3, 5, 40 & 50 HP Ø 9.940"	
5	30400815	Shaft sleeve	1
6	92010016	Slinger	1
7	31030133	Mechanical seal	1
8	92010033	O-ring	1
9	91010351	Cap screw 1/2" x 1-1/2" SS	1
10	91010062	Lock washer 1/2" SS	1
11	30400416B	Impeller Washer	1
12	30400633	Shaft key	1
13	91010309	Stud 1/2" x 1-3/4"	8
14	91010415	Hex. nut 1/2"	8
15	91010014	Lock washer 1/2"	8
16	91010243	Cap screw 3/8" x 1" for 3 & 5 HP	4
	91010282	Cap screw 5/8" x 1-1/2" for 30 to 50 HP	
17	91010012	Lock washer 3/8" for 3 & 5 HP	4
	91010015	Lock washer 5/8" for 30 to 50 HP	
18	91010242	Cap screw 3/8" x 1"	4
19	91010012	Lock washer 3/8"	4
20	03190010	Wear plate	1
21	92010191	Wear plate gasket	1
22	31010008	Retaining ring	1
23	30400317	Wear ring	1
24	93010143	Pipe plug 1/4"	5

To order any spare part please supply the model and serial number as shown on the nameplate, and the description and part number as shown in the parts list.

*With 284/6 JM shaft extension

TYPICAL EXPLODED VIEW CENTRIFUGAL PUMP

MODELS:
* IA4

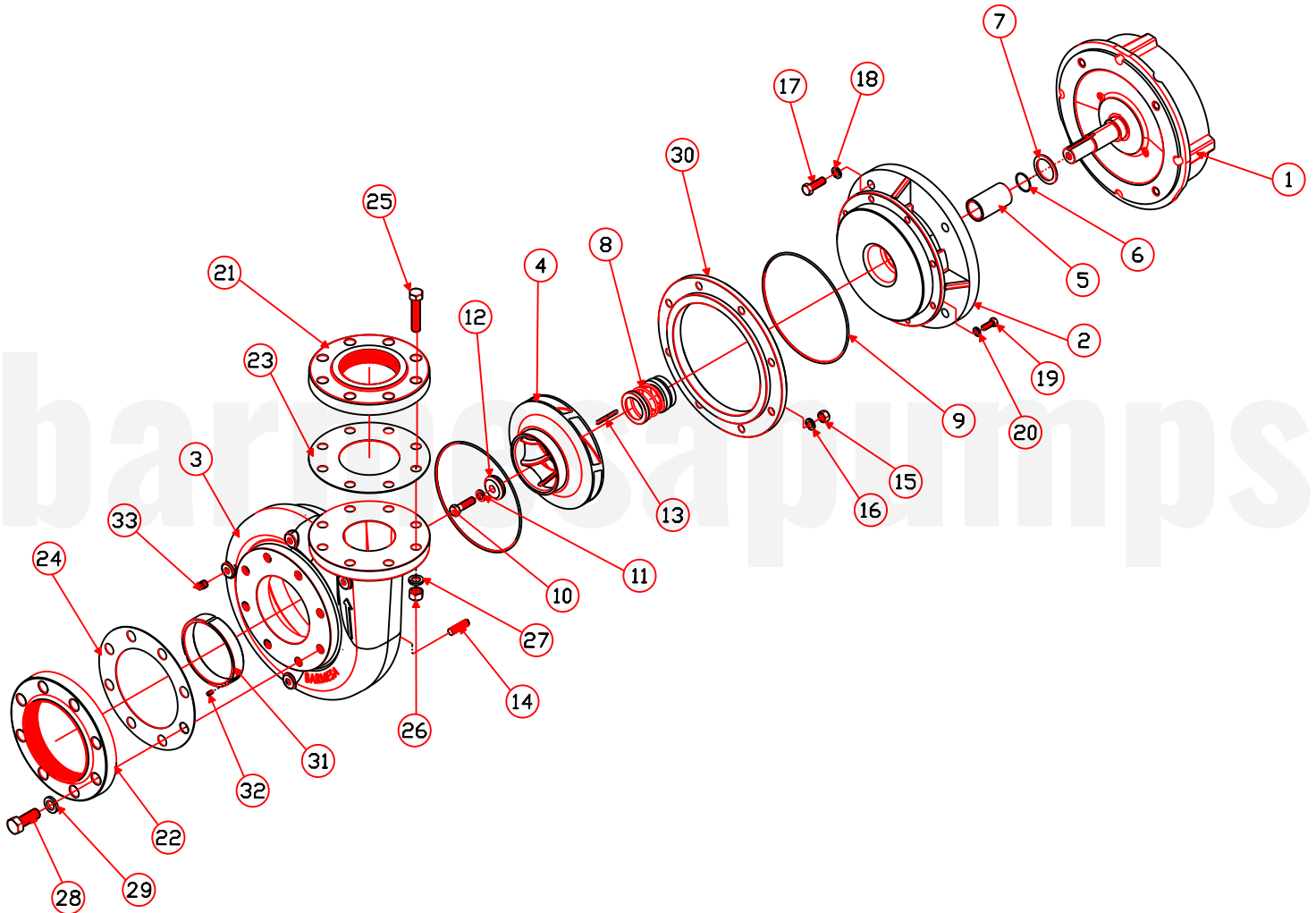

To order any spare part please supply the model and serial number as shown on the nameplate, and the description and part number as shown in the parts list.

► IA4

Item	Part. No.	Description	Qty.
1	40020132	10 HP, 1800 RPM, 3 Ph, frame 213/5TCZ	1
	40020021	15 HP, 1800 RPM, 3 Ph, frame 254/6JM	
	40020024	20 HP, 1800 RPM, 3 Ph, frame 254/6JM	
	40020032	40 HP, 3500 RPM, 3 Ph, frame 324/6JM	
	40020034	50 HP, 3500 RPM, 3 Ph, frame 324/6JM	
	40020036	60 HP, 3500 RPM, 3 Ph, frame 364/5JM	
	40020038	75 HP, 3500 RPM, 3 Ph, frame 364/5JM	
	40020040	100 HP, 3500 RPM, 3 Ph, frame 405TCZ	
	40020042	125 HP, 3500 RPM, 3 Ph, frame 444JM	
2	03010018C	Intermediate coupling for 10 to 20 HP	1
	03010032	Intermediate coupling for 40 to 125 HP	
3	03090043	Volute	1
4	03140036D	Impeller IA4 for 10 HP, Ø 8.38"	1
	03140036F	Impeller IA4 for 15 HP, Ø 9.88"	
	03140036G	Impeller IA4 for 20 HP, Ø 10.44"	
	03140036I	Impeller IA4 for 40 HP, Ø 7.31"	
	03140036B	Impeller IA4 for 50 HP, Ø 7.75"	
	03140036C	Impeller IA4 for 60 HP, Ø 8.188"	
	03140036D	Impeller IA4 for 75 HP, Ø 8.75"	
	03140036H	Impeller IA4 for 100 HP, Ø 9.63"	
	03140036G	Impeller IA4 for 125 HP, Ø 10.44"	
5	30400812	Shaft sleeve	1
6	92010029M	Shaft Sleeve O-ring	1
7	92010016	Slinger	1
8	31030133B	Mechanical seal	1
9	92010033	O-ring	2
10	91010351	Impeller's screw 1/2 x 1 1/2" SS	1
11	91010062	Lock washer 1/2" SS	1
12	30400419	Impeller's washer	1
13	30400633	Shaft key 1/4"	1
14	91010309	Stud 1/2 x 1 3/4"	8
15	91010415	Hex nut 1/2"	8
16	91010014	Lock washer 1/2"	8
17	91010263	Cap screw for 1/2 x 1 1/2" for 10 to 20	4
	91010282	Cap screw for 5/8 x 1 1/2" for 40 to 125 HP	
18	91010014	Lock washer 1/2" for 10 to 20	4
	91010015	Lock washer 5/8" for 40 to 125 HP	
19	91010242	Cap screw 3/8 x 1"	8
20	91010012	Lock washer 3/8"	8
21	03060006	Flange discharge 4"	1
22	03060011	Flange suction 6"	1
23	92010156	Gasket for flange 4"	1
24	92010158	Gasket for flange 5 "	1
25	91010285	Cap screw 5/8 x 3"	8
26	91010015	Lock washer 5/8"	8
27	91010416	Hex nut 5/8"	8
28	91010292	Cap screw 3/4 x 2"	8
29	91010016	Lock washer 3/4"	8
30	03020018	Adapter	1
31	30400319	Wear ring	1
32	91010170	Socket set screw	3
33	93010143	Pipe plug 1/4" NPT	4

To order any spare part please supply the model and serial number as shown on the nameplate, and the description and part number as shown in the parts list.



Risk of electric shock. Always disconnect the pump from the power source before handling inspections or repairs.

PROBLEM	PROBABLE CAUSE	CHECK
A) The pump does not prime, the vacuum gauge indicates a lower reading than normal.	1. Air leak in the suction system.	- Threaded joints in the suction tightness. - Gaskets for no wear. - The mechanical seal for leaks. - The drain plug has leaks. - The vacuum gauge may be leaking.
	2. Insufficient liquid in the pump casing.	- That the pump's body is filled with water.
	3. Low operating speed.	- The motor speed (RPM).
	4. Bound pump.	- Impeller rotates freely. - Internal parts are clean.
	5. Mechanical defect.	- That the internal parts are not worn.
B) The pump does not prime, the vacuum gauge reading indicates higher than normal.	1. Pipe clogged suction.	- The suction line is clean.
C) The pump priming good vacuum gauge reading is normal, the manometer indicates a lower pressure than normal.	1. The pump speed is very low.	- The voltage is correct.
	2. Mechanical defects.	- The internal parts for wear.
D) The pump priming good vacuum gauge reading is almost normal, reading the manometer is greater.	1. Discharge obstructed.	- The discharge is clear of obstructions. - That the discharge valves operate correctly.
E) The pump loses its priming during operation, vacuum gauge reading drops to zero.	1. suction dynamic level too high.	- When the pump is operating, never lacks water in the suction.
	2. The pump is sucking air.	- For leaks in suction piping, flanges and gaskets. - That there is no vortex effect at the end of the suction, this lack of water.
F) The pump priming pumps well and satisfactorily but noisy.	1. Pump base is loose.	- That screws are tight at the base. - There are no cracks in the base.
	2. Cavitation.	- The dynamic level is not too high - That the pumping capacity is not too much. - The pump is operating in the range of NPSHR - If reducing flow makes the noise gone, then the problem is in the point above; partially close the discharge valve.
	3. Bearings.	- The bearings for wear. - That there is oil in the deposit.
	4. Vibration.	- The impeller does not have any foreign material. - The pump is operating in the range. - That the alignment is correct.
G) Motor overload.	1. Low Voltage.	- The voltage is correct.
	2. Overload.	- The amperage of the plate is not exceeded. - There is no foreign material that may force the impeller. - That the motor is suitable for the pump.

NOTE: Barmesa Pumps assumes no responsibility for damage or injury due to disassembly in the field. Disassembly of the pumps or supplied accessories other than at Barmesa Pumps or its authorized service centers, automatically voids warranty.

BARMESA PUMPS FACTORY WARRANTY

Barmesa Pumps warrants that products of our manufacture will be free of defects in material and workmanship under normal use and service for 18 months from date of manufacture or 12 months from installation date whichever occurs first. This warranty gives you specific legal rights, which vary from state to state.

This warranty is a limited warranty, and no warranty related claims of any nature whatsoever shall be made against Barmesa Pumps, until the ultimate consumer or his/her successor notifies us in writing of the defect and delivers the product and/or defective part(s) freight prepaid to our factory or nearest authorized service station as instructed by Barmesa Pumps. THERE SHALL BE NO FURTHER LIABILITY, WHETHER BASED ON WARRANTY, NEGLIGENCE OR OTHERWISE. PRODUCT SHALL BE EITHER REPLACED OR REPAIRED AT THE ELECTION OF BARMESA PUMPS. Guarantees relating to performance specifications provided in addition to the foregoing material and workmanship warranties on a product manufactured by Barmesa Pumps, if any, are subject to possible factory testing. Any additional guarantees, in the nature of certified performance specifications or time frame must be in writing and such writing must be signed by our authorized factory manager at time of order placement and/or at time of quotation. Due to inaccuracies in field testing and should a conflict arises between the results of field testing conducted by or for the user, Barmesa Pumps reserves the right to have the product returned to our factory for additional testing.

This warranty shall not apply when damage is caused by (1) improper installation, (2) improper voltage, (3) lightning, (4) excessive sand or other abrasive material, (5) corrosion build-up due to excessive chemical content or (6) uncontrollable acts of god. Any modification of the original equipment will also void the warranty. We will not be responsible for loss, damage or labor cost due to interruption of service caused by defective pumps, parts or systems. Barmesa Pumps will not accept charges incurred by others without our prior written approval.

This warranty is void if our inspection reveals the product was used in a manner inconsistent with normal industry practice and/or our specific recommendations. The purchaser is responsible for communication of all necessary information regarding the application and use of the product. UNDER NO CIRCUMSTANCES WILL WE BE RESPONSIBLE FOR ANY OTHER DIRECT OR CONSEQUENTIAL DAMAGES, INCLUDING BUT NOT LIMITED TO TRAVEL EXPENSES, CONTRACTOR FEES, UNAUTHORIZED REPAIR SHOP EXPENSES, LOST PROFITS, LOST INCOME, LABOR CHARGES, DELAYS IN PRODUCTION, IDLE PRODUCTION, WHICH DAMAGES ARE CAUSED BY ANY DEFECTS IN MATERIAL AND/OR WORKMANSHIP AND/OR DAMAGE OR DELAYS IN SHIPMENT. THIS WARRANTY IS EXPRESSLY IN LIEU OF ANY OTHER EXPRESS OR IMPLIED WARRANTY. No rights extended under this warranty shall be assigned to any other person, whether by operation of law or otherwise, without our prior written approval.

IMPORTANT!

If you have a claim under the provision of the warranty, contact Barmesa Pumps or your authorized Barmesa Pumps Distributor:
warranty@barmesapumps.com
www.barmesapumps.com

